



## Operator's manual



**Please read this manual carefully before using the machine!**

### Keep for future use

This operator's and assembly manual is an integral part of the machine. Suppliers of new and second-hand machines are required to document in writing that the operator's and assembly manual was delivered with the machine and handed over to the customer.

**UKS 80 - 300**

5901337-h-en-0125

Original instructions

## Foreword

Dear customer,

By purchasing the **Universal Hopper Spreader** of the series UKS you have shown confidence in our product. Thank you very much! We want to justify this confidence. You have purchased a powerful and reliable machine.

However, in case unexpected problems arise, our customer service department is always there for you.



**Please read this operator's manual carefully before commissioning the universal hopper spreader and follow the instructions given.**

This operator's manual gives detailed instructions on the operation of the machine, as well as valuable information on assembly, maintenance, and care.

This manual may also describe equipment that is not included in your machine.

Please note that damage caused by incorrect operation or improper use cannot be covered by warranty claims.



Please enter here your model type and serial number, together with the year of manufacture of your hopper spreader.

This information is provided on the machine nameplate or on the frame.

Please state this information when ordering spare parts or optional equipment, and in the event of complaints.

Type:

Serial number:

Year of manufacture:

## Technical improvements

We continuously strive to improve our products. For this reason, we reserve the right to make any improvements and changes to our machine that we consider necessary without notice. We do not accept any obligation to make such improvements or changes on machines that have already been sold.

We will be pleased to answer any other questions that you might have.

Yours sincerely

RAUCH Landmaschinenfabrik GmbH

# Table of contents

<b>1</b>	<b>Intended use</b> .....	<b>7</b>
1.1	Intended use.....	7
<b>2</b>	<b>User instructions</b> .....	<b>8</b>
2.1	About this operator's manual.....	8
2.2	Structure of the operator's manual.....	8
2.3	Notes on text descriptions.....	9
2.3.1	Instructions and procedures.....	9
2.3.2	Lists.....	9
2.3.3	References.....	9
<b>3</b>	<b>Safety</b> .....	<b>10</b>
3.1	General information.....	10
3.2	Meaning of warnings.....	10
3.3	General information on the safety of the machine.....	11
3.4	Instructions for the operator.....	11
3.4.1	Qualifications of personnel.....	11
3.4.2	Instruction.....	12
3.4.3	Accident prevention.....	12
3.5	Information on operational safety.....	12
3.5.1	Parking the machine.....	12
3.5.2	Filling the machine.....	13
3.5.3	Checks before commissioning the machine.....	13
3.5.4	Running operation.....	13
3.6	Use of the spreading material.....	13
3.7	Hydraulics system.....	14
3.8	Maintenance and service.....	14
3.8.1	Qualifications of maintenance personnel.....	15
3.8.2	Wear parts.....	15
3.8.3	Maintenance and service tasks.....	15
3.9	Safety in traffic.....	15
3.9.1	Checks before driving.....	16
3.9.2	Road travel with the machine.....	16
3.10	Safety equipment, warnings and instructions.....	17
3.10.1	Position of safety equipment as well as warning and instruction stickers.....	17
3.10.2	Function of safety equipment.....	18
3.11	Warning and instruction stickers.....	18
3.11.1	Warning stickers.....	19
3.11.2	Instruction stickers.....	19
3.12	Name plate and machine marking.....	20
3.13	Reflector.....	21
<b>4</b>	<b>Machine data</b> .....	<b>22</b>
4.1	Manufacturer.....	22
4.2	Versions.....	22

---

4.2.1	UKS spreader for use in winter .....	22
4.2.2	UKS GB fertilizer spreader.....	22
4.3	Technical specifications.....	23
4.3.1	UKS spreader for use in winter .....	23
4.3.2	UKS GB fertilizer spreader.....	24
4.4	Technical data for the extensions .....	25
4.4.1	UKS spreader for use in winter .....	25
4.4.2	UKS GB fertilizer spreader.....	25
<b>5</b>	<b>Transport without tractor .....</b>	<b>26</b>
5.1	General safety instructions.....	26
5.2	Loading and unloading, parking .....	26
<b>6</b>	<b>Commissioning .....</b>	<b>27</b>
6.1	Accepting the machine .....	27
6.2	Tractor requirements.....	27
6.3	Adjusting the chain tensioner roller .....	27
6.3.1	Clockwise power take-off drive.....	27
6.3.2	Anticlockwise power take-off drive.....	28
6.4	Mounting the universal drive shaft on the machine .....	29
6.4.1	Check length of the PTO drive shaft.....	29
6.4.2	Mounting/dismounting the universal drive shaft.....	30
6.5	Installing the machine at the tractor .....	32
6.5.1	Preconditions.....	32
6.5.2	Rear attachment .....	32
6.5.3	Front mounting (only UKS GB).....	35
6.6	Connecting the actuator .....	36
6.7	Connecting the hydraulic drive .....	36
6.8	Filling the machine .....	38
6.9	Parking and unhitching the machine.....	39
<b>7</b>	<b>Machine settings.....</b>	<b>41</b>
7.1	Setting the spreading quantity .....	41
7.1.1	UKS with mechanical adjustment of the spreading quantity .....	41
7.2	Using the spreading tables.....	42

7.2.1	Information on the fertilizer chart.....	42
7.2.2	List of spreading tables.....	44
7.2.3	Application table for grit, sand, salt.....	45
7.2.4	Application table for white mustard.....	47
7.2.5	Application table for lupins, yellow, white.....	48
7.2.6	Application table for oil radish.....	49
7.2.7	Application table for phacelia.....	50
7.2.8	Application table for oilseed rape.....	51
7.2.9	Application table for red clover.....	52
7.2.10	Application table for rye grass.....	53
7.2.11	Application table for vetches.....	54
7.2.12	Application table for turnip rape.....	55
7.2.13	Application table for Agricorn, Günther Corufera GmbH.....	56
7.2.14	Application table for prilled urea, SKW Piesteritz.....	58
7.2.15	Application table for calcium ammonium nitrate, Raiffeisen.....	59
7.2.16	Application table for calcium cyanide, SKW Trostberg.....	60
7.2.17	Application table for converter lime.....	61
7.2.18	Application table for NPK MALTAFLOR.....	63
7.2.19	Application table for Maxiflor 92, finely ground, Maxit Kalkwerke.....	65
7.2.20	Application table for Nitrophoska perfect COMP BASF.....	66
7.2.21	Application table for Nitrozol Top Spiess Urania.....	67
7.2.22	Application table for NPK Raiffeisen.....	68
7.2.23	Application table for patent potash magnesia, Kali + Salz GmbH.....	69
7.2.24	Application table for Rasenstolz NPK, Spiess Urania.....	70
7.2.25	Application table for castor cake Agricolan (pellets) Günther.....	71
7.2.26	Application table for castor cake Agricolan (grist) Günther.....	72
7.2.27	Application table for superphosphate Donau Chemie.....	73
7.2.28	Application table for Basamid Compo.....	74
7.2.29	Application table for Basatop Sport COMPO BASF.....	75
7.2.30	Application table for Basatop Starter COMPO BASF.....	76
7.2.31	Application table for Floranid N32 COMPO BASF.....	77
7.2.32	Application table for Floranid NK COMPO BASF.....	78
7.2.33	Application table for Floranid Permanent COMPO BASF.....	79
7.2.34	Application table for Sportica K COMPO BASF.....	80
<b>8</b>	<b>Calibration test.....</b>	<b>81</b>
8.1	Calculate the maximum spreading distance.....	81
8.2	Determining the target discharge rate per minute.....	81
8.2.1	Example 1: Sand, salt and grit (g/min).....	82
8.2.2	Example 2: Spreading material (kg/min).....	82
8.3	Implementing the calibration test.....	83
<b>9</b>	<b>Valuable instructions for spreading work.....</b>	<b>85</b>
9.1	General recommendations.....	85
9.2	Procedure for spreading the spreading material.....	85
9.3	Discharging residual material.....	87
9.3.1	Emptying the hopper - UKS 80 to UKS 120.....	87
9.3.2	Emptying the hopper - UKS 150 GB to UKS 300 GB.....	88

<b>10 Maintenance and service</b> .....	<b>90</b>
10.1 Safety.....	90
10.2 Wear parts and screw connections.....	91
10.2.1 Checking wear parts.....	91
10.2.2 Checking the bolted connections.....	91
10.3 Cleaning.....	91
10.4 Check the agitator shaft for wear.....	92
10.4.1 Check the chain for wear and tension.....	92
10.5 Transmission oil.....	92
10.5.1 Quantities and types.....	92
10.5.2 Checking the oil level, changing the oil.....	93
10.6 Lubrication plan.....	94
<b>11 Faults and possible causes</b> .....	<b>95</b>
<b>12 Optional equipment is available</b> .....	<b>96</b>
12.1 UKS spreader for use in winter.....	96
12.1.1 Electrical remote control EF 25.....	96
12.1.2 Mechanical remote control MFB 6/MFB 7.....	96
12.1.3 Extensions.....	96
12.1.4 Hopper tarpaulins.....	96
12.1.5 Lighting and warning signs (UKS 80/100/120).....	96
12.1.6 Lower link connection Cat. I, long.....	97
12.1.7 Lower link connection Cat. I N.....	97
12.1.8 Frame triangle Cat. I.....	97
12.1.9 Hydraulic flow control valve (special design, UKS 100/120).....	97
12.2 UKS GB fertilizer spreader.....	97
12.2.1 Electrical remote control EF 25.....	97
12.2.2 Mechanical remote control MFB 6/MFB 7.....	97
12.2.3 Extensions.....	97
12.2.4 Support stand feet.....	98
12.2.5 Windshield.....	98
12.2.6 Hopper tarpaulins.....	98
12.2.7 Lighting without warning signs.....	98
12.2.8 Row spreading system.....	99
12.2.9 Spreader mechanism.....	99
12.2.10 Set of parts for category I (UKS 150, UKS 190).....	99
12.2.11 Set of parts for category II.....	99
12.2.12 Frame triangle Cat. II.....	99
<b>13 Axle load calculation</b> .....	<b>100</b>
13.1 Calculation of the axle loading.....	100
13.2 Table of axles loadings.....	103
<b>14 Disposal</b> .....	<b>104</b>
14.1 Safety.....	104
14.2 Disposal of the machine.....	104
<b>15 Guarantee and warranty</b> .....	<b>105</b>

# 1 Intended use

## 1.1 Intended use

The universal hopper spreaders of the series UKS are constructed in accordance with their intended use and may be exclusively used for the points listed below:

- In winter it can be used to spread free-flowing materials such as sand, salt and grit up to size 3/8.
- In agriculture, for application of dry granular crystalline fertilizers,
- in agriculture, for application of seeds,
- in road construction, for application of materials with good spreading properties, such as grit up to size 3/8.

Any use over and beyond these specifications is considered to be contrary to the intended use. The manufacturer shall not assume any liability for any damages resulting from this. The risk is solely carried by the operator.

The intended use also comprises the compliance with the operating maintenance and servicing conditions prescribed by the manufacturer. When fitting spare parts, only those that are the manufacturer's original spare parts may be used.

Universal hopper spreaders of series UKS may be used, maintained and repaired only by persons familiar with the characteristics of the machine and who have been instructed about the relevant hazards.

The instructions regarding the operation, service, and safe handling of the machine as described in the operator's manual and declared by the manufacturer in the form of warning signs and symbols on the machine must be strictly followed during operation.

The relevant accident prevention regulations and other generally recognized safety-related, occupational health and road traffic regulations must be observed when using the machine.

Unauthorized modifications to the UKS universal hopper spreaders are not permitted. These exclude any liability of the manufacturer for any resulting damages.

### **Foreseeable misuse**

The manufacturer provides warning notes and signs on the UKS universal hopper spreader relating to foreseeable misuse. These warning notes and signs must be complied with under all circumstances, in order to avoid using the UKS universal hopper spreader in a way other than intended according to the operator's manual .

## 2 User instructions

### 2.1 About this operator's manual

This operator's manual is an **integral part** of the machine.

The operator's manual contains important instructions for **safe, proper**, and economic **use** and **maintenance** of the machine. Compliance with its stipulations helps to **avoid risks**, reduce repair costs and downtime, and to increase the reliability and service life of the machine controlled with it.

The complete documentation, comprising this operator's manual and any other documents provided, must be kept in an easily accessible location close to where the machine is used (e.g., in the tractor).

If the machine is sold, the operator's manual must also be passed to the new owner.

The operator's manual is intended for the operator of the machine and anyone involved in operating and maintaining it. It must be read, understood, and applied by every person who is entrusted with the following work on the machine:

- Operation,
- Maintenance and cleaning,
- Troubleshooting.

In particular, the following is to be observed:

- The chapter on safety,
- The warnings in the text of the individual chapters.

The operator's manual does not replace your **own responsibility** as operator and operational staff of the machine control unit.

### 2.2 Structure of the operator's manual

The operator's manual is divided into six key areas in terms of content

- User instructions
- Safety instructions
- Machine data
- Instructions on operating the machine
- Instructions for finding and correcting faults
- Maintenance and service instructions

## 2.3 Notes on text descriptions

### 2.3.1 Instructions and procedures

Steps that must be performed by operating staff are displayed as follows

- ▶ Instructions step 1
- ▶ Instructions step 2

### 2.3.2 Lists

Lists without a specific sequence are shown as lists with bullet points:

- Property A
- Property B

### 2.3.3 References

References to other sections in the document are shown with paragraph number, header text and/or page number:

- **Example:** Please also note 3 *Safety*

References to other documents are shown as information or instructions without the exact chapter or page number:

- **Example:** Follow the instructions in the operator's manual of the universal drive shaft manufacturer.

## 3 Safety

### 3.1 General information

The chapter **Safety** contains basic warning notes as well as working and traffic safety instructions for the usage of the installed machine.

The adherence to the instructions in this chapter is a prerequisite for the safe handling and trouble-free operation of the machine.

There are additional warnings in the other chapters of this operator's manual, which must also be observed. The warning instructions are given before the text for the relevant actions.

Warning notes on the supplier components can be found in the respective supplier documentation. These warning instructions must also be observed.

### 3.2 Meaning of warnings

The warnings in the operator's manual are classified according to the severity of the risk and the probability of its occurrence.

The warning symbols draw attention to the residual risks to which users of the machine are exposed. The warnings used are structured as follows:

---

Symbol + **signal word**

Explanation

---

#### Level of danger of warnings

The level of danger is indicated in the signal word. The levels of danger are classified as follows:

#### **DANGER!**

##### **Type and source of danger**

This warning warns of a danger posing an immediate threat to the health and life of people.

Ignoring these warnings will result in severe injury or death.

- ▶ Always observe the measures described to prevent this danger.

#### **WARNING!**

##### **Type and source of danger**

This warning warns of a potentially dangerous situation for personal health.

Ignoring these warnings leads to severe injury.

- ▶ Always observe the measures described to prevent this danger.

**⚠ CAUTION!****Type and source of danger**

This warning warns of a potentially dangerous situation for personal health.

Ignoring these warnings leads to injury.

- ▶ Always observe the measures described to prevent this danger.

**NOTICE!****Type and source of danger**

This warning warns of material and environmental damage.

Ignoring these warnings will result in damage to the machine and to the environment.

- ▶ Always observe the measures described to prevent this danger.



This is an instruction:

General instructions contain tips for the operation and information that is particularly useful, but no warnings about hazards.

### 3.3 General information on the safety of the machine

The machine is state-of-the-art and is compliant with the applicable technical regulations. However, during its use and maintenance, risks to the health and life of the user or third parties or damage to the machine and other objects can still occur.

For this reason, the machine may only be operated:

- In a flawless and roadworthy condition,
- Taking into account safety and risks.

This requires you to have read and understood the contents of this operator's manual. You must be aware of the relevant accident prevention regulations as well as the generally acknowledged safety, occupational health and traffic regulations and be able to apply them.

### 3.4 Instructions for the operator

The owner is responsible for the intended use of the machine.

#### 3.4.1 Qualifications of personnel

Before starting any work on or with the machine, all persons who are involved in operation, maintenance or service must have read and understood this operator's manual.

- The machine may only be operated by instructed personnel authorized by the owner.
- Persons who are apprentices, in training or under instruction may only work on the machine under the supervision of an experienced person.
- Maintenance and service may only be carried out by qualified maintenance personnel.

### 3.4.2 Instruction

Distribution partners, works representatives or employees of the manufacturer will instruct the operator regarding the operation and maintenance of the machine.

The owner must ensure that newly recruited operating and maintenance personnel are instructed to the same extent and with the same care with regard to the operation and repair of the machine in compliance with this operator's manual.

### 3.4.3 Accident prevention

Safety and accident prevention regulations are legally specified in every country. The owner of the machine is responsible for observing the regulations applicable in the country of operation.

The following instructions must also be observed:

- Never let the machine run without supervision.
- Do not ride on the machine while it is working or being transported (**no passengers**).
- **Do not use** machine parts as steps.
- Always wear tight fitting clothes. Do not wear work clothes with belts, loose threads or other items that could get caught.
- Follow the manufacturer's warnings when handling chemicals. You may have to wear personal protective equipment (PPE).

## 3.5 Information on operational safety

Only use the machine in safe operating condition. Avoid hazardous situations.

### 3.5.1 Parking the machine

- Park the machine only with an empty hopper and on level firm ground.
- When the machine is parked alone (not attached to a tractor), open the metering slide completely (any water in the container will then drain out).

### 3.5.2 Filling the machine

- Only fill the machine when the engine of the tractor is shut off. Remove the ignition key in order to prevent the engine from being started.
- Make sure that there is adequate space on the filling side. Make sure to pay attention to a potential collision with the swivel frame cylinders.
- Use suitable auxiliary equipment for filling the machine (e.g. front-end loader, feed screw conveyor).
- Fill the machine no higher than the top-edge. Check the filling level.
- Only fill the machine with the protective grid closed. This way, faults during spreading caused by lumps in the spreading material or other foreign bodies are prevented.

### 3.5.3 Checks before commissioning the machine

Check the operating safety of the machine before the first and every subsequent commissioning.

- Is all safety equipment at the machine installed and functioning?
- Are all fasteners and load-bearing connections tightly fitted and in good condition?
- Are the protective grids in the hopper closed and locked?
- Are there **no** persons in the danger zone of the machine?
- Is the chain guard box on the hopper closed and are the fastening screws tight?

### 3.5.4 Running operation

- In the event of malfunctions, the machine is to be shut down and secured immediately. Have the fault repaired immediately by qualified technicians.
- Do not climb on the machine while the spreader unit is running.
- Only operate the machine with the protective grids in the hopper closed. During operation, the protective grid must **neither be opened nor removed**.
- Rotating machine components can cause serious injury. Make sure that body parts or clothing never come close to rotating components.
- Do not deposit any parts (such as screws, nuts) in the hopper.
- Ejected spreading material may cause serious injury (e.g., to the eyes). For this reason, ensure that nobody is present in the spreading range of the machine.
- If the wind speed becomes too high, spreading has to be stopped as the specified spreading range cannot be guaranteed under such conditions.
- Do not climb on the machine or the tractor when it is situated beneath high-voltage electrical power lines.
- Do not operate the universal hopper spreader unless the chain guard box is closed.

## 3.6 Use of the spreading material

### Use of fertilizers, seeds or crop protection products

Improper selection or use of fertilizers, seeds or crop protection products may cause serious injury or environmental damage.

- When selecting the fertilizers, seeds or crop protection products, inform yourself of its effects on humans, the environment and the machine.
- Refer to the instructions and safety data sheets issued by the manufacturers.

### 3.7 Hydraulics system

The hydraulic system is under high pressure.

Fluid escaping under high pressure may cause serious injury and environmental damage. The following instructions must be observed to prevent danger:

- Always operate the machine below the permissible maximum operating pressure.
- **Release the pressure** from the hydraulic system **before** carrying out any maintenance. Switch off the engine of the tractor. Secure it against reactivation.
- When searching for leaks, always wear safety **glasses** and safety **gloves**.
- In case of injury in connection with hydraulic oil, consult **a physician immediately** as severe infections may occur.
- When connecting the hydraulic hoses to the tractor, ensure that the hydraulic system is **depressurized**, both on the tractor and the machine side.
- Attach the hydraulic hoses of the tractor and the spreader hydraulic systems only with the prescribed connections.
- Prevent any contamination of the hydraulic circuit. Always suspend the couplings in the brackets provided. Use the dust caps. Clean the connections before coupling them.
- Regularly check the hydraulic components and hydraulic hose lines for mechanical defects, e.g., cuts and abrasions, contusions, bends, tears, porosity, etc.
- Even when stored correctly and used within approved load limits, hoses and hose couplings are subject to a natural aging process. This limits their storage and service life.

The hydraulic hoses are designed for a maximum service life of 6 years, including storage for a maximum of 2 years.

The month and year of manufacture of the hydraulic hoses is stamped on the hose fitting.

- Have the hydraulic hoses replaced if they are damaged and after the specified service life has been reached.
- Replacement hydraulic hoses must meet the technical requirements of the equipment manufacturer. Make sure the replacement hydraulic hoses meet the maximum pressure specifications.

### 3.8 Maintenance and service

Maintenance and service involve additional hazards that do not occur during operation of the machine.

Always take particular care when performing maintenance and service work. Work with particular care and be aware of the hazards.

### 3.8.1 Qualifications of maintenance personnel

- Welding and work on the electrical and hydraulic systems is to be carried out by qualified technicians only.

### 3.8.2 Wear parts

- The maintenance and service intervals described in the present operator's manual are to be strictly adhered to at all times.
- Also observe the maintenance and service intervals for the supplied components. See the supplier documentation for the relevant intervals.
- We recommend having your dealer check the condition of the machine, particularly fastening components, safety-relevant plastic components, the hydraulic system, metering components and spreading vanes, after every working season.
- Spare parts must at least comply with the technical standards specified by the manufacturer. Compliance with technical requirements is ensured using original spare parts.
- Self-locking nuts are designed to be used only once. Always use new self-locking nuts to fasten components (e.g., when replacing spreading vanes).

### 3.8.3 Maintenance and service tasks

- **Always switch off the tractor engine** before any cleaning, maintenance, service, and troubleshooting. **Wait until all rotating parts of the machine have come to a standstill.**
- Make sure that unauthorized persons **cannot** start the machine. Remove the ignition key of the tractor.
- Disconnect the power supply between the tractor and the machine before performing any maintenance and service tasks or before working on the electrical system.
- Check that the tractor with the machine is correctly parked. Park the spreader with an empty hopper on level, solid ground and secure it to prevent it from moving.
- Secure the lifted machine additionally against falling (e.g., by means of a safety stand) when carrying out maintenance and repair work or inspections under the lifted machine.
- Release the pressure from the hydraulic system before any maintenance and repair work.
- Only open the protective grid in the hopper if the machine has been decommissioned.
- If work is to be carried out while the PTO shaft is rotating, make sure that nobody is near the PTO or the universal drive shaft.
- Never clear blockages in the spreader hopper by hand or with the foot: always use a suitable tool.
- When cleaning with high-pressure, never aim the water jet directly at warning signs, electrical equipment, hydraulic components, and sliding bearings.
- Regularly check nuts and screws for tightness. Retighten loose connections.

## 3.9 Safety in traffic

When driving on public streets and roads, the tractor with the attached machine must comply with the road traffic regulations of the respective country. The owner and driver are responsible for compliance with these regulations.

### 3.9.1 Checks before driving

The check before departure is an important contribution to road safety. Before every trip, check compliance with the operating conditions, traffic safety, and the regulations of the country of operation.

- Is the vehicle within the permissible overall weight? Note the permitted axle load, the permitted braking load, and the permitted tire load capacity;
  - See *13 Axle load calculation*
- Is the machine attached correctly?
- Can fertilizer be lost while traveling?
  - Observe the filling level of the fertilizer in the hopper.
  - The metering slides must be closed.
  - Switch off the electronic control unit.
- Check the tire pressures and the function of the tractor brake system.
- Do the lighting and labeling on the machine comply with the national regulations for operation on public roads? Ensure correct attachment.
- Is the boarding step folded away and locked / is the boarding step in the transport position? (machine-dependent)

### 3.9.2 Road travel with the machine

Handling, steering, and braking performance of the tractor are affected by the attached machine. For example, an excessive weight of the machine will reduce the weight on the front axle of the tractor and affect the steering.

- Adapt your driving to the modified driving characteristics.
- When driving, always ensure that there is sufficient visibility. If vision is restricted (e.g. when reversing), another person is required to direct the driver.
- Observe the admissible maximum speed.
- Avoid sudden turns when driving uphill or downhill or across a slope. The change in the center of gravity may increase the danger of tipping. Special care is to be particularly applied when driving on uneven, soft ground (e.g. when entering fields, curbs).
- Arrest sideways movement of the lower link of the three-point linkage to prevent the machine from swinging.
- Passengers are prohibited on the machine during transport and operation.

### 3.10 Safety equipment, warnings and instructions

#### 3.10.1 Position of safety equipment as well as warning and instruction stickers

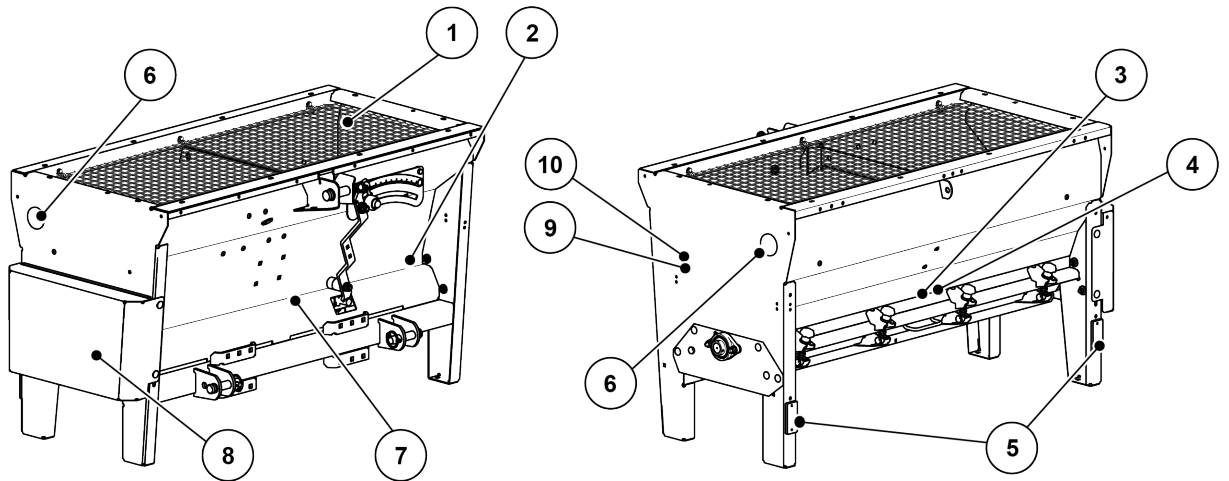

Fig. 1: Safety equipment, warning and instruction stickers

- |                                      |   |
|--------------------------------------|---|
| [1] Protective grid in the hopper    | [6] Yellow side reflectors              |
| [2] Name plate                       | [7] Instructions: PTO speed             |
| [3] Warning: moving parts            | [8] Chain guard box                     |
| [4] Warning: Remove the ignition key | [9] Warning: Read the operator's manual |
| [5] Red rear reflectors              | [10] Instruction: Maximum payload       |

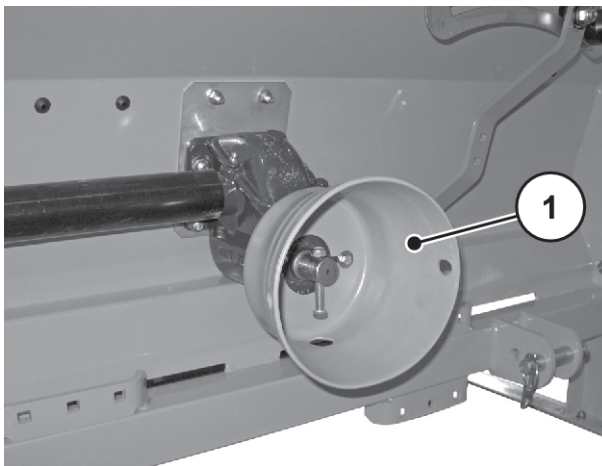

Fig. 2: Safety equipment, universal drive shaft guard

- [1] Universal drive shaft guard

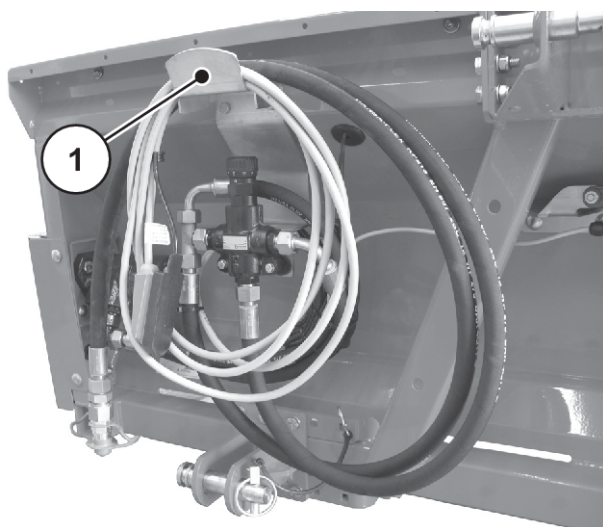

Fig. 3: Bracket for cables and hoses

[1] Bracket for cables and hoses

### 3.10.2 Function of safety equipment

The safety equipment is designed to protect your health and life.

- Before working with the machine, ensure that the safety equipment is functioning and not damaged.
- Only operate the machine when the safety equipment is functional.

Designation	Function
Protective grid in hopper	Prevents body parts from being caught by the rotating agitator. Prevents body parts from being cut off by the metering slide. Prevents faults during spreading caused by lumps in the spreading material, large stones, or other large objects (screening effect).
Universal drive shaft guard	Prevents body parts and clothing from being pulled into the rotating universal drive shaft.
Bracket	Attachment of the hoses and cables to the frame. Prevents the hoses and cables from being crushed or kinked. See Fig. <i>Bracket for cables and hoses 18</i>
Chain guard	Prevents parts of the body being caught up in the chain.

### 3.11 Warning and instruction stickers

Various warning and instruction stickers are attached to the machine (for the position at the machine, please refer to 3.10.1 *Position of safety equipment as well as warning and instruction stickers*).

The warning and instruction stickers are components of the machine. They must not be removed or modified.



- ▶ Replace missing or illegible warning and instruction stickers immediately.

If new components are installed during repairs, the same warning and instruction stickers that were on the original parts must be placed on the new parts.



The correct warning and instruction stickers can be obtained from the spare parts service.

### 3.11.1 Warning stickers

Illustration	Description
	Read the operator's manual and warnings. Read and observe the operator's manual and warnings before commissioning the machine. The operator's manual explains in detail how to operate the spreader and contains valuable information on operation, care and maintenance.
	Remove the ignition key. Switch off the engine and remove the key before carrying out maintenance and repair work. Disconnect the power supply
	Danger due to moving parts Danger of cutting off body parts It is prohibited to reach into the hazard zone of rotating parts. Switch off the engine and remove the key before carrying out maintenance, repair and adjustment work.

### 3.11.2 Instruction stickers





Illustration	Description
	Rated speed of the PTO shaft The rated speed of the PTO shaft is 540 rpm.

Illustration	Description
	<p>Rated speed of the PTO shaft The rated speed of the PTO shaft is 1000 rpm.</p>
	<p>Maximum load capacity</p>
	<p>Maximum load capacity</p>
	<p>Maximum load capacity</p>

### 3.12 Name plate and machine marking



When delivering your machine, ensure that all necessary signs are present.

Depending on the country of destination, additional signs can be attached to the machine.

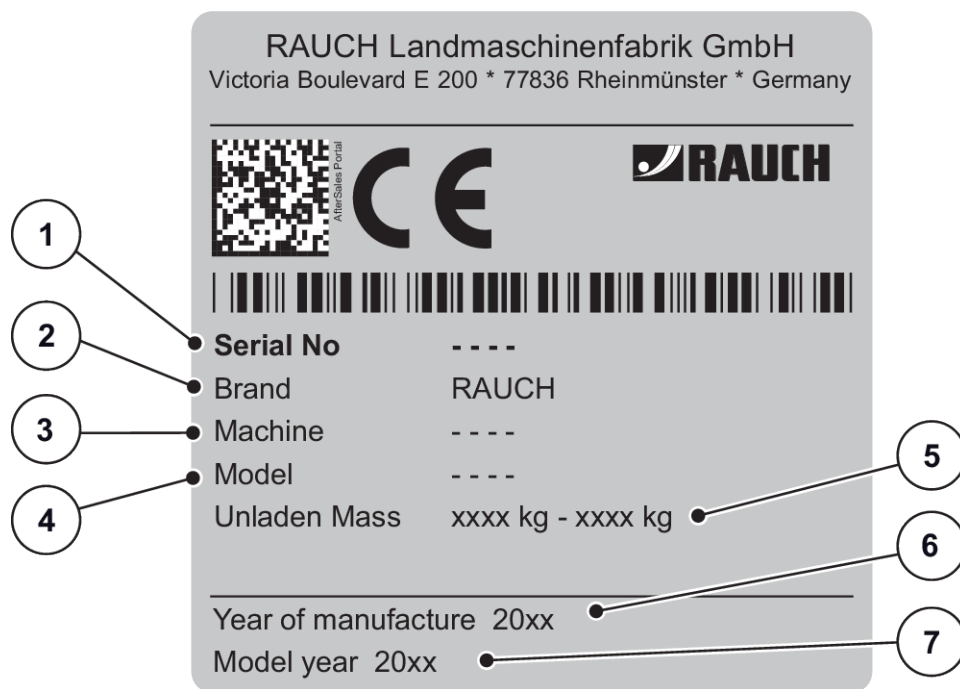

Fig. 4: Nameplate

- |                   |                          |
|-------------------|--------------------------|
| [1] Serial number | [5] Empty weight         |
| [2] Manufacturer  | [6] Year of construction |
| [3] Machine       | [7] Model year           |
| [4] Type          |                          |

### 3.13 Reflector

The lighting equipment must be attached as specified and must always be in operating condition. Lights must not be covered or obscured by dirt.

The machine is factory-equipped with passive front, rear, and side lighting (for the attachment to the machine, please refer to *3.10.1 Position of safety equipment as well as warning and instruction stickers*).

## 4 Machine data

### 4.1 Manufacturer

RAUCH Landmaschinenfabrik GmbH  
Victoria Boulevard E 200  
77836 Rheinmünster  
Germany

Phone: +49 (0) 7229 8580-0

Fax: +49 (0) 7229 8580-200

#### Service Center, Technical Customer Service

RAUCH Landmaschinenfabrik GmbH  
PO box 1162  
Email: [service@rauch.de](mailto:service@rauch.de)  
Fax: +49 (0) 7229 8580-203

### 4.2 Versions

#### 4.2.1 UKS spreader for use in winter

Type Function	UKS 80		UKS 100		UKS 100 Q	UKS 120		UKS 120 Q
Drive with universal drive shaft	x		x			x		
Drive with hydraulic motor		x		x	x		x	x
Electronic spreading quantity control					x			x

#### 4.2.2 UKS GB fertilizer spreader

Type Functions	UKS 150	UKS 150 Q	UKS 190	UKS 190 Q	UKS 230	UKS 230 Q	UKS 300	UKS 300 Q
Drive with hydraulic motor	x	x	x	x	x	x	x	x
Electronic spreading quantity control		x		x		x		x

## 4.3 Technical specifications

### 4.3.1 UKS spreader for use in winter

#### ■ Dimensions

Data		UKS 80	UKS 100	UKS 120
Total width		98 cm	118 cm	138 cm
Overall length		70 cm	70 cm	70 cm
Filling level		75 cm	75 cm	75 cm
Distance of the center of gravity from the lower link coupling point	Cat. 1N	31 cm	30.5 cm	30.5 cm
	Frame triangle	27 cm	27 cm	27 cm
Spreading width		80 cm	100 cm	120 cm
Hopper size (L×W)		87x62 cm	106x62 cm	125x62 cm
Power take-off shaft speed	minimum	450 rpm	450 rpm	450 rpm
		1000 rpm	1000 rpm	1000 rpm
	maximum	600 rpm	600 rpm	600 rpm
		1100 rpm	1100 rpm	1100 rpm
Nominal speed		540 rpm	540 rpm	540 rpm
		1000 rpm	1000 rpm	1000 rpm
Mass flow <sup>1</sup>		250 kg/min	250 kg/min	250 kg/min
Hydraulic pressure		200 bar	200 bar	200 bar
Sound pressure level <sup>2</sup> (in the enclosed driver's cab of the tractor)		75 dB(A)	75 dB(A)	75 dB(A)

#### ■ Weights and loads



The empty weight (mass) of the universal hopper spreader varies depending on the feature package and attachments combination. The tare weight shown on the nameplate refers to the standard version.

<sup>1)</sup> Maximum mass flow depending on the type of grit to be spread

<sup>2)</sup> Since the sound pressure level of the universal hopper spreader can be determined only when the tractor is running, the actual value is greatly dependent on the type of tractor being used.

Data		UKS 80	UKS 100	UKS 120
Empty weight		105 kg	120 kg	130 kg
Payload	maximum	500 kg	500 kg	500 kg
Hopper capacity		165 l	200 l	240 l
Upper link		Cat. I + II	Cat. I + II	Cat. I + II
Lower link		Cat. I N	Cat I / Cat I N	Cat I / Cat I N
Frame triangle		Cat. I	Cat. I	Cat. I

### 4.3.2 UKS GB fertilizer spreader

#### ■ Dimensions

Data		UKS 150 GB	UKS 190 GB	UKS 230 GB	UKS 300 GB
Total width		168 cm	208 cm	248 cm	318 cm
Overall length		70 cm	70 cm	70 cm	70 cm
Filling level (basic machine)		60 cm	60 cm	60 cm	60 cm
Distance between the center of gravity and lower link coupling point	Cat. II	35 cm	35 cm	35 cm	35 cm
	Cat. I	31 cm	31 cm	-	-
	Frame triangle	43 cm	43 cm	43 cm	43 cm
Spreading width		150 cm	190 cm	230 cm	300 cm
Hopper size (WxL)		157x62 cm	196x62 cm	235x62 cm	310x62 cm
Mass flow <sup>3</sup>		250 kg/min	250 kg/min	250 kg/min	
Sound pressure level <sup>4</sup> (in the enclosed driver's cab of the tractor)		75 dB(A)	75 dB(A)	75 dB(A)	

<sup>3</sup>) Maximum mass flow depending on the type of grit to be spread.

<sup>4</sup>) Since the sound pressure level of the universal hopper spreader can be determined only when the tractor is running, the actual value is greatly dependent on the type of tractor being used.

## ■ Weights and loads



The empty weight (mass) of the universal hopper spreader varies depending on the feature package and attachments combination. The tare weight shown on the nameplate refers to the standard version.

Data		UKS 150 GB	UKS 190 GB	UKS 230 GB	UKS 300 GB
Empty weight		160 kg	180 kg	210 kg	260 kg
Payload	maximum	700 kg	700 kg	700 kg	1000 kg
Hopper capacity		300 l	370 l	440 l	580 l
Upper link		Cat. I + II	Cat. I + II	Cat. I + II	Cat. II
Lower link		Cat I / Cat II	Cat I / Cat II	Cat. II	Cat. II
Frame triangle		Cat. II	Cat. II	Cat. II	Cat. II

## 4.4 Technical data for the extensions

### 4.4.1 UKS spreader for use in winter

Data with extension	UKS 80	UKS 100	UKS 120
Hopper capacity	230 l	280 l	340 l
Filling level	90 cm	90 cm	90 cm
Total width	98 cm	118 cm	138 cm

### 4.4.2 UKS GB fertilizer spreader

Data with extension	UKS 150 GB	UKS 190 GB	UKS 230 GB	UKS 300 GB
Hopper capacity	420 l	510 l	610 l	830 l
Filling level	75 cm	75 cm	75 cm	75 cm
Total width	168 cm	208 cm	248 cm	318 cm

## 5 Transport without tractor

### 5.1 General safety instructions

Read the following instructions before transporting the machine:

- Without tractor, the machine may only be transported with an empty hopper.
- Only suitable, instructed and expressly authorized persons may execute the work.
- Suitable means of transportation and lifting equipment (e.g. crane, forklift truck, lifting tackle ...) are to be used.
- Establish the transportation route in good time and remove possible obstacles.
- Check that all safety and transportation devices are fully operational.
- Secure all danger areas appropriately, even if they only exist briefly.
- The person responsible for transportation ensures that the machine is transported appropriately.
- Unauthorized persons are to be kept away from the transport route. Cordon off the affected areas!
- Transport the machine cautiously and handle it with care.
- Ensure that allowances are made for the center of gravity. If necessary, adjust the cables to ensure that the machine is correctly aligned on the means of transport.
- Transport the machine to the set-up location as close to the ground as possible.
- Allow sufficient clearance between the base of the spreader and the loading area.

### 5.2 Loading and unloading, parking

- ▶ Determine the weight of the machine.
  - ▷ Check the details on the name plate.
  - ▷ Take the weight of mounted optional equipment into account.
- ▶ Carefully lift the machine with suitable lifting equipment.
- ▶ Carefully place the machine on the loading platform of the transportation vehicle or on solid ground.

## 6 Commissioning

### 6.1 Accepting the machine

When accepting the machine, please check the completeness of the delivery.

**The standard equipment includes:**

- 1 universal hopper spreader of series UKS
- 1 operator's manual UKS with spreading table
- Lower link pin and upper link pin or coupling triangle
- Agitator shaft
- Protective grid in the hopper
- 1 universal drive shaft (including operator's manual); not included if the drive is by hydraulic motor.

Also check the completeness of any additional special equipment ordered.

Check for any transport damage or missing parts. Have any shipping damage confirmed by the forwarding agent.



When receiving the machine, check that attached components are correctly and tightly positioned.

In case of doubt, please contact your dealer or the factory directly.

### 6.2 Tractor requirements

To ensure safe and correct use of the machine of the UKS series, the tractor must meet the necessary mechanical, hydraulic, and electrical requirements.

- Universal drive shaft connection: 1 3/8 inches, 6-part, 540 rpm or 1000 rpm
- Three-point linkage category I or category II. (depending on the type)
- Three-point linkage category I N is also available as special equipment.
- Operating voltage: 12 V
- **Oil supply** (hydraulic drive):
  - 1 single-acting control valve
  - 1 free return
  - Oil supply: Max. 200 bar

### 6.3 Adjusting the chain tensioner roller

#### 6.3.1 Clockwise power take-off drive

The universal hopper spreader UKS is fitted as standard with the Z17/Z40 chain sprocket set.

The chain tensioner roller [1] is factory-fitted underneath the chain for a clockwise drive.

In this arrangement the agitator shaft of the universal hopper spreader is driven at a power take-off shaft rotational speed of 540 rpm or 1000 rpm.

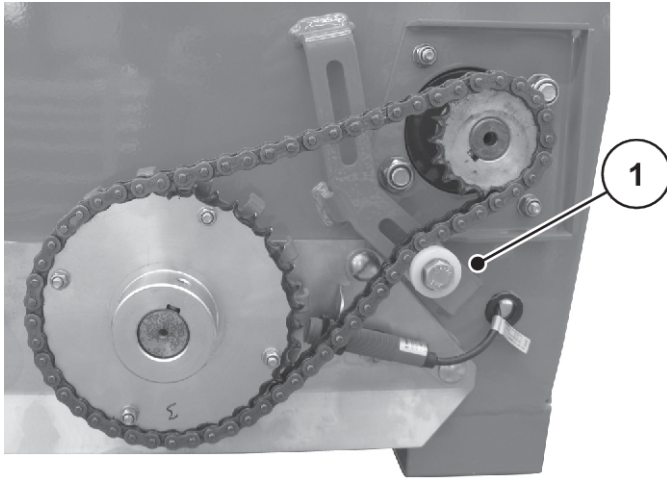

*Fig. 5: Installation of the chain tensioner roller (for a clockwise power take-off drive)*

[1] Chain tensioner roller

### 6.3.2 Anticlockwise power take-off drive

If the power take-off drive is anticlockwise, the chain tensioner roller is mounted above the chain.

In this arrangement the agitator shaft of the universal hopper spreader is driven at a power take-off shaft rotational speed of 540 rpm or 1000 rpm.

#### **Mounting the chain tensioner roller above the chain**

- ▶ Take off the chain guard box.
- ▶ Undo the screw from the chain tensioner roller [1].
- ▶ Take the chain tensioner roller [1] out of the opening in the lower plate.
- ▶ Insert the chain tensioner roller [1] into the opening in the upper plate.
- ▶ Position the chain tensioner roller [1] so that the chain is sufficiently tensioned.
- ▶ Tighten the screw.
- ▶ Reattach the chain guard box.

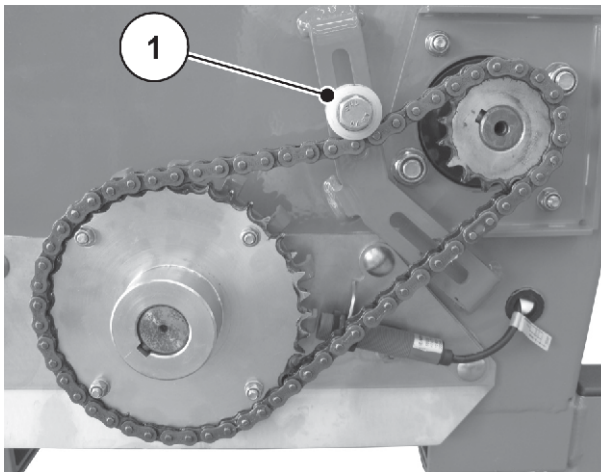

Fig. 6: Installation of the chain tensioner roller (for an anti-clockwise power take-off drive)

[1] Chain tensioner roller

## 6.4 Mounting the universal drive shaft on the machine

### **! WARNING!**

#### **Risk of injury and damage to property if an unsuitable universal drive shaft is used**

The machine is equipped with a universal drive shaft that is designed according to the device and performance.

The use of incorrectly dimensioned or inadmissible drive shafts, for instance without guard or suspension chain, may cause personal injury or lead to damage to the tractor and/or the machine.

- ▶ Use only universal drive shafts approved by the manufacturer.
- ▶ Follow the directions in the operator's manual of the universal drive shaft manufacturer.

### 6.4.1 Check length of the PTO drive shaft

- ▶ Check the length of the universal drive shaft when first attaching it to the tractor.

*Drive shaft tubes that are too long could damage the universal drive shaft and the universal hopper spreader.*



Observe the installation and shortening instructions provided in the operator's manual of the universal drive shaft manufacturer when checking and adjusting the universal drive shaft. The operator's manual is attached to the drive shaft on delivery.

## 6.4.2 Mounting/dismounting the universal drive shaft

### DANGER!

#### Danger of pulling in on the rotating universal drive shaft

Installing and removing the universal drive shaft while the motor is running may cause serious injuries (crushing, pulling into the rotating shaft).

- ▶ Switch off the tractor engine.
- ▶ Remove the ignition key.

#### Mounting:

- ▶ Check the mounting position.

*The drive shaft end that is marked with a sticker showing a tractor symbol must be towards the tractor.*

- ▶ Remove the hexagon head screw and hexagon nut from the drive spigot.



Fig. 7: Universal drive shaft

- ▶ Grease the drive spigot.
- ▶ Plug the universal drive shaft on to the drive spigot.



Fig. 8: Drive spigot

- ▶ Insert a hexagon head screw from below through the hole in the universal drive shaft guard.



*Fig. 9: Inserting a hexagon head screw*

- ▶ Tighten the hexagon head screw and nut using a size 13 wrench (**maximum 18 Nm**).

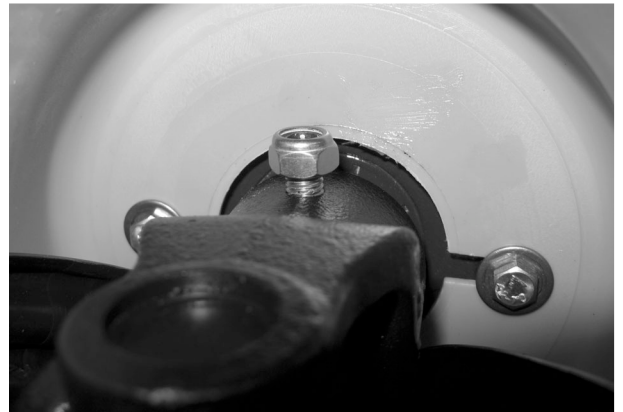

*Fig. 10: Tightening the hexagon head screw*

**Notes for removal:**

- Removal of the universal drive shaft is the reverse order of mounting.
- After uncoupling it, hang the universal drive shaft from the support chain.

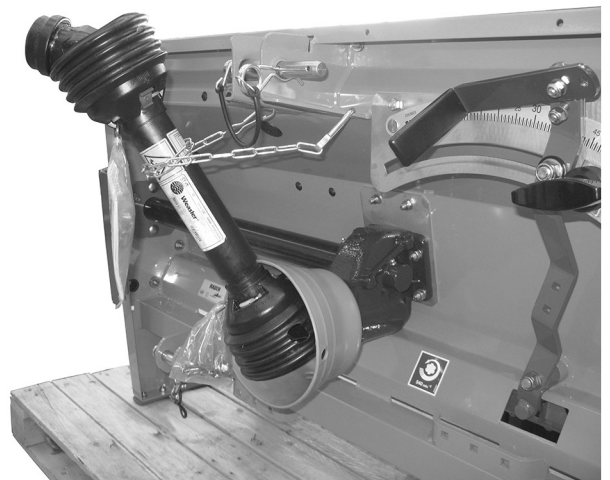

*Fig. 11: Hanging up the universal drive shaft*

## 6.5 Installing the machine at the tractor

### 6.5.1 Preconditions

#### **DANGER!**

##### **Danger to life due to unsuitable tractor**

Using an unsuitable tractor for the machine may result in severe accidents during operation or road travel.

- ▶ Only use tractors that comply with the technical requirements of the machine.
- ▶ Refer to the vehicle documents in order to check whether the tractor is suitable for the machine.

##### **Check the following specific preconditions:**

- Are both the tractor and the machine safe to operate?
- Does the tractor comply with the mechanical, hydraulic, and electrical requirements?
- Do the mounting categories of the tractor and the machine match (if necessary, consult your dealer)?
- Is the machine securely positioned on level and solid ground?
- Do the axle loads conform to the stipulated calculations?

### 6.5.2 Rear attachment

#### **DANGER!**

##### **Danger to life due to carelessness or incorrect operation**

There is a crushing hazard that may result in fatal injury for persons standing between the tractor and the machine when the tractor approaches or the hydraulic system is actuated.

The tractor may brake too late or not at all because of carelessness or incorrect operation.

- ▶ Ensure that nobody is present in the hazard zone between the tractor and the machine.

#### **DANGER!**

##### **Risk of tipping or falling**

There are no anchor or lifting points provided on the attachments or the frame of the machine.

If the machine is lifted or moved on the attachments or the frame, it may tip over or fall. There is a risk of death.

- ▶ Fasten the machine to a pallet.

Attach the machine to the three-point linkage (rear power lift)

**Mounting instructions:**

- UKS 100 and UKS 120: The connection to a tractor with Cat. II can be made only at the Cat. I distance and by plugging on reducing sleeves.
- UKS 150, UKS 190, UKS 230 and UKS 300: The connection to a tractor with Cat. III can be made only at the Cat. II distance and by plugging on reducing sleeves.
- UKS 80, UKS 100 and UKS 120: The connection to a tractor with Cat. 1N can be made only using an adapter.
- The bottom and upper link pins must be secured with lynch pins or spring clips.
- Always connect the universal hopper spreader so that it is horizontal.
- To prevent the universal hopper spreader swinging back and forth during spreading, attach it so that it is horizontal and rigid transversely to the direction of travel.
- Check the correct locking of the frame triangle.



We recommend using lower link hooks with a hydraulic upper link for safety and comfort.

**Requirement**

- The PTO shaft is switched off.
- ▶ Start the tractor.
  - ▶ Drive the tractor up to the universal hopper spreader.
    - ▷ Do not latch the lower link hooks into place yet.
    - ▷ When connecting the drives and controls, ensure sufficient clearance between the tractor and the universal hopper spreader.



If a greater clearance between the tractor and the universal hopper spreader is required, use the extended version of the lower link coupling point. Refer to chapter 12 *Optional equipment is available*

- ▶ Switch off the tractor engine. Switch off at the ignition switch.
- ▶ Mount the universal drive shaft on the tractor.
- ▶ Connect the electrical actuation of the slide, the hydraulic drive and the lighting (see chapter 6.7 *Connecting the hydraulic drive*).
- ▶ From the tractor cab, connect the lower link hook and the upper link to the designated coupling points; please refer to the operator's manual of your tractor.

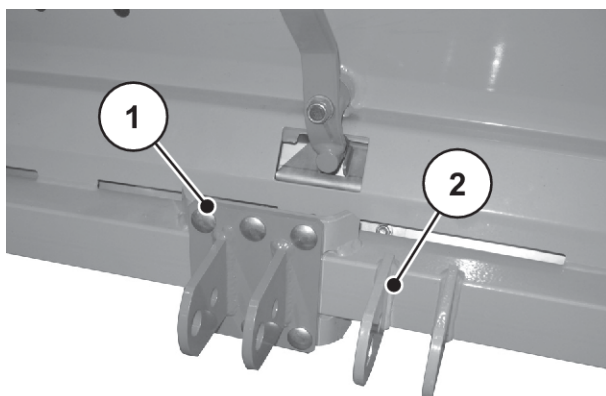

Fig. 12: Lower link coupling points UKS 80, UKS 100 and UKS 120

- [1] Coupling point, category 1N (special equipment for UKS 80/100/200) [2] Coupling point, category 1 (standard equipment for UKS 100/120)

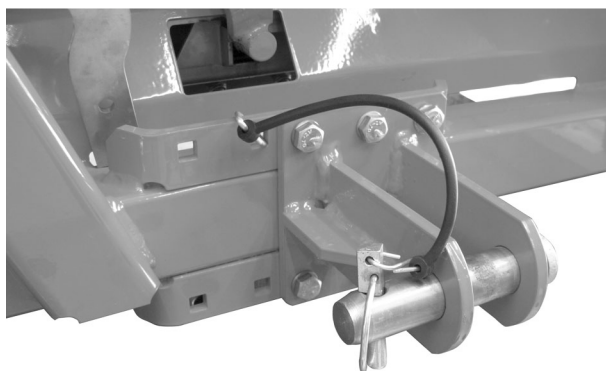

Fig. 13: Lower link coupling point from UKS 150 GB, category II



We recommend using lower link hooks with a hydraulic upper link for safety and comfort.

- ▶ Check that the universal hopper spreader is securely attached.

### **⚠ CAUTION!**

#### **Material damage caused by a universal drive shaft that is too long**

When the universal hopper spreader is lifted up, the halves of the universal drive shaft can come into contact with each other. This may cause damage to the universal drive shaft, to the gearbox or the universal hopper spreader.

- ▶ Check the clearance between the universal hopper spreader and the tractor.
  - ▶ Make sure that there is enough space (at least 20 to 30 mm) between the outer tube of the universal drive shaft and the hopper guard on the spreading side.
- ▶ Shorten the universal drive shaft, if required.



Entrust only your dealer or specialist workshop with the task of shortening the universal drive shaft.



Observe the installation and shortening instructions provided in the operator's manual of the universal drive shaft manufacturer when checking and adjusting the universal drive shaft. The operator's manual is attached to the drive shaft on delivery.

### 6.5.3 Front mounting (only UKS GB)

#### **DANGER!**

##### **Danger to life due to carelessness or incorrect operation**

There is a crushing hazard that may result in fatal injury for persons standing between the tractor and the machine when the tractor approaches or the hydraulic system is actuated.

The tractor may brake too late or not at all because of carelessness or incorrect operation.

- ▶ Ensure that nobody is present in the hazard zone between the tractor and the machine.

Attach the universal hopper spreader to the three-point linkage.

Mounting instructions:

- The connection to a tractor with category III can be made only at the category II distance and by plugging on reducing sleeves.
- The bottom and upper link pins must be secured with lynch pins or spring clips.
- Check the correct locking of the frame triangle.

- ▶ Start the tractor.
- ▶ Drive the tractor up to the universal hopper spreader.
  - ▷ Do not latch the lower link hooks into place yet.
  - ▷ When connecting the drives and controls, ensure sufficient clearance between the tractor and the universal hopper spreader..



If a greater clearance between the tractor and the universal hopper spreader is required, use the extended version of the lower link coupling point. See *12 Optional equipment is available*

- ▶ Switch off the tractor engine. Switch off at the ignition switch.
- ▶ Connect the electric and hydraulic slide actuators and the lighting (see *6.7 Connecting the hydraulic drive* ).
- ▶ From the tractor cab, connect the lower link hook and the upper link to the designated coupling points; please refer to the operator's manual of your tractor.



We recommend using lower link hooks with a hydraulic upper link for safety and comfort.

- ▶ Check that the universal hopper spreader is securely attached.

## 6.6 Connecting the actuator

Depending on the model, the universal hopper spreader UKS may be equipped with an actuator for electronic regulation of the quantity that is applied (see chapter *4.2 Versions*).

The actuator is connected to its own control unit in the tractor

### Connection

- ▶ Please refer to the operator's manual for the control unit QUANTRON A for UKS.

## 6.7 Connecting the hydraulic drive

Depending on the model, the universal hopper spreader UKS may be equipped with a hydraulic motor as a drive for the agitator.

A single-acting control valve and a free return flow are needed on the tractor. An additional check valve is installed in the return line.

The hydraulic drive is connected to the tractor via 2 hydraulic hoses.



- Connect the plug with the red protective cap to the pressure line
- Connect the plug with the blue protective cap to the return line.
- Do not allow the hydraulic hoses that were removed to hang down to the ground.
- Always put dust caps on hydraulic hoses when they are removed.
- Place the disconnected hydraulic hoses over the bracket for hoses and cables (see Fig. 18)

### Adjusting the hydraulic drive

The universal hopper spreader is driven by a hydraulic motor with a 315 cm<sup>3</sup> displacement volume. A volumetric output of 20 l/min from the tractor (at rated speed) then results in an agitator speed of approx. 25-30 rpm.

- ▶ Adjust the agitator speed to a value between 10 rpm and 40 rpm.

The agitator shaft of the universal hopper spreader UKS 100 Q, UKS 120 Q together with UKS GB are always hydraulically driven.

- ▶ Set the agitator speed at the handwheel of the flow control valve.

The flow control valve is available as an accessory for the series UKS 100 and UKS 120.

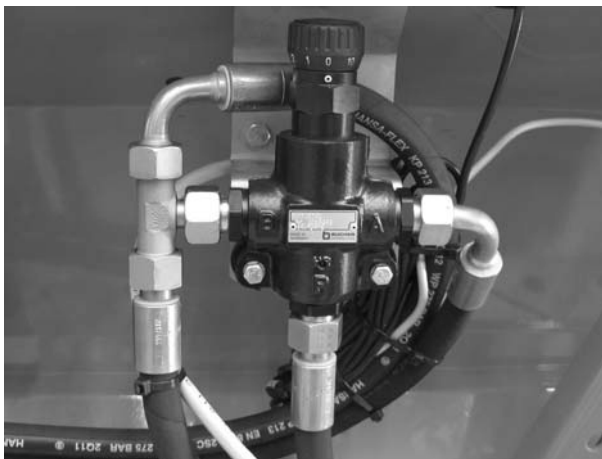

Fig. 14: Flow control valve

### ■ Controlling the speed of the agitator shaft

Handwheel setting	Speed of the agitator shaft (rpm)
2.5	8
3	17
3.5	25
4	33

To maintain the condition of the fertilizer, at small openings of the metering slide and for fertilizers that are free-flowing, reduce the agitator speed (at the handwheel of the flow control valve).

For fertilizers that are not free-flowing and are floury, increase the agitator speed (at the handwheel of the flow control valve).



After any change to the speed of the spreader shaft, perform a calibration test.



Check the speeds for correctness in conjunction with the tractor you are using.

## 6.8 Filling the machine

### **DANGER!**

#### **Danger of injury due to running engine**

Working on the machine with the engine running may result in serious injury caused by mechanical components and escaping spreading material.

- ▶ Wait until all moving parts have come to a complete stop before making any adjustments or performing maintenance work.
- ▶ Switch off the tractor engine.
- ▶ Remove the ignition key.
- ▶ Ensure that nobody is present **in the hazard zone**.

### **DANGER!**

#### **Danger due to inadmissible overall weight**

Exceeding the overall weight can lead to breakage during operation and negatively affects the operational and road safety of the vehicle (machine and tractor).

Serious personal injury is possible as well as material and environmental damage.

- ▶ Always observe the information in chapter *4.3 Technical specifications*.
- ▶ Prior to filling, determine the maximum quantity to be loaded.
- ▶ Observe the admissible overall weight.

Instructions for filling the universal hopper spreader:

- Close the metering slide.
- Fill the universal hopper spreader **only** when it is coupled to a tractor. Make sure that the tractor is standing on level and solid ground.
- Secure the tractor against rolling away. Apply the handbrake.
- Switch off the engine of the tractor. Remove the ignition key.
- From a filling height higher than 1.25 m, use a facility (such as a front loader or a conveying screw) to fill the universal hopper spreader.
- Make sure there is sufficient air clearance between the floor of the hopper and the ground.
- Fill the universal hopper spreader no higher than the top edge.

## 6.9 Parking and unhitching the machine

The machine can safely be put down on to its frame or support feet.

### **DANGER!**

#### **Crush hazard between the tractor and the machine**

Persons standing between the tractor and the machine while they are being parked or decoupled are in lethal danger.

- ▶ Make sure that when the external operation controls for three-point attachment are activated, no-one is standing between the tractor and the machine.

### **CAUTION!**

#### **Material damage due to parking at an unsuitable location**

Parking at an unsuitable location can lead to material damage to the machine. Foreign bodies lying on the ground can distort the metering mechanism.

- ▶ Make sure there is sufficient clearance between the floor of the hopper and the ground.
- ▶ If necessary, put the machine back on to its transport pallet for storage.

#### **Requirements for parking the machine:**

- Park the machine only on flat solid ground.
- If necessary, swing out the parking feet.
- Park the machine only with an empty hopper.
- Relieve the load on the coupling points (lower link / upper link) before removing the machine.
- After uncoupling the hydraulic hoses and electrical cables from the frame, lay them on the storage shelf provided.

The universal hopper spreader can safely be put down on to its frame.

 **DANGER!**

**Crush hazard between the tractor and the machine**

Persons standing between the tractor and the machine while they are being parked or decoupled are in lethal danger.

- ▶ Make sure that when the external operation controls for three-point attachment are activated, no-one is standing between the tractor and the machine.

 **CAUTION!**

**Material damage due to parking at an unsuitable location**

Parking at an unsuitable location can lead to material damage to the machine. Foreign bodies lying on the ground can distort the metering mechanism.

- ▶ Make sure there is sufficient clearance between the floor of the hopper and the ground.
- ▶ If necessary, put the machine back on to its transport pallet for storage.

**Requirements for parking the universal hopper spreader:**

- Park the universal hopper spreader only on flat solid ground.
- Park the universal hopper spreader only with an empty hopper.
- Relieve the load on the coupling points (lower link / upper link) before removing the universal hopper spreader.
- After uncoupling the hydraulic hoses and electrical cables from the frame, lay them on the holder provided (see Fig. *Fig. 3 Bracket for cables and hoses*).
- Hang the universal drive shaft from the support chain (see Fig. *Fig. 11 Hanging up the universal drive shaft*).

## 7 Machine settings

### **⚠ DANGER!**

#### **Danger of injury due to running engine**

Working on the machine with the engine running may result in serious injury caused by mechanical components and escaping spreading material.

- ▶ Wait until all moving parts have come to a complete stop before making any adjustments or performing maintenance work.
- ▶ Switch off the tractor engine.
- ▶ Remove the ignition key.
- ▶ Ensure that nobody is present **in the hazard zone**.

**When performing adjustments to the machine, note the following points:**

- The quantity adjustment is always performed with closed metering slides.

### 7.1 Setting the spreading quantity



The version of the universal hopper spreader UKS with QUANTRON A is equipped with electronic actuation of the metering slide for adjusting the spreading quantity.

The electronic metering slider actuation is described in the separate supplementary instructions in the operator's manual QUANTRON A. This operator's manual is an integral part of the control unit QUANTRON A.

#### 7.1.1 UKS with mechanical adjustment of the spreading quantity

The spreading quantity is set by means of a stop on the scale.

### **NOTICE!**

#### **Material damage caused by an insufficient metering slide opening**

Insufficiently opened metering slides may lead to blocking and cause damage to the spreading material. Increasing wear occurs at the agitator.

- ▶ Select an adequately large opening for the metering slide at which the spreading material can flow out unhindered.

**Procedure for setting the application rate.**

- ▶ Close the metering slide.

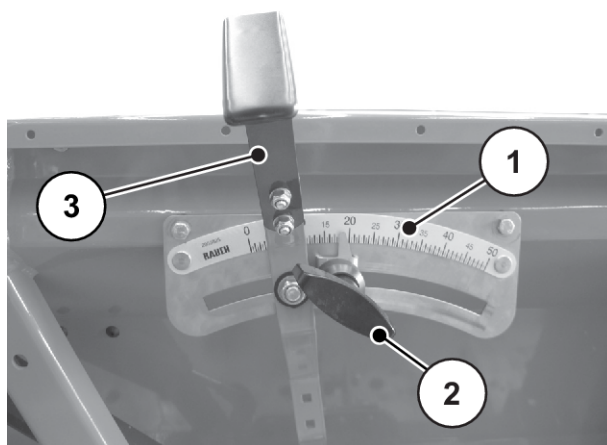

Fig. 15: Metering slide adjustment

[1] Application rate scale  
[2] Stop

[3] Spreading quantity adjustment lever

- ▶ Move the stop [2] to the position (pointer) that you have previously looked up in the spreading table or have determined by means of a calibration test.
- ▶ Before starting spreading, move the quantity adjustment lever [3] to the stop.
  - ▷ Adjusting it in the direction of higher values opens the metering slide.
  - ▷ Adjusting it in the direction of lower values closes the metering slide.

## 7.2 Using the spreading tables

### 7.2.1 Information on the fertilizer chart

The universal hopper spreader calibration unit was used to determine the values in the spreading tables.

The spreading material used for this was obtained from the manufacturers of the spreading material or from dealers. Experience shows that the spreading material available to you, even if the specifications are identical, may have different spreading properties due to storage, transport, and many other reasons.

Together with the settings indicated in the spreading material charts, this may lead to different application rates and a less optimal spreading material distribution.

The following instructions should therefore be observed:

- **For grit, sand, salt:** spreading trials are performed with 2 different PTO shaft speeds.
  - 540 rpm; agitator shaft speed 15 rpm
  - 1000 rpm; agitator shaft speed 28 rpm
- Always check the actual application rate discharged by performing a calibration test (see *Chapter 8 - Calibration test - Page 81*).
- For spreading materials not listed in the spreading material chart, determine the adjustments by means of calibration.
- Observe the adjustment values exactly. Even a slightly incorrect setting may adversely affect the spreading pattern.

When using urea, particular attention is to be paid to the following:

- Because of fertilizer imports, urea is available in widely varying qualities and particle sizes. It may therefore be required to adjust the spreader settings.
- Urea is more sensitive to windy conditions and also absorbs more moisture than other spreading materials.

***NOTICE!***

**The operator is responsible the correct adjustments for the spreading material in use.**

We point out specifically that we do not accept any liability for damage resulting from incorrect spreader settings.

***NOTICE!***

**See our homepage under for other spreading tables for your universal hopper spreader.**

We specifically point out that we do not accept any liability for damage arising from incorrect spreader settings.

## 7.2.2 List of spreading tables

Table	Page
Application table for grit, sand, salt	45
Application table for white mustard	47
Application table for lupins, yellow, white	48
Application table for oil radish	49
Application table for phacelia	50
Application table for oilseed rape	51
Application table for red clover	52
Application table for rye grass	53
Application table for vetches	54
Application table for turnip rape	55
Application table for Agricorn, Günther Corufera GmbH	56
Application table for prilled urea, SKW Piesteritz	58
Application table for calcium ammonium nitrate, Raiffeisen	59
Application table for calcium cyanide, SKW Trostberg	60
Application table for converter lime	61
Application table for NPK MALTAFLOR	63
Application table for Maxiflor 92, finely ground, Maxit Kalkwerke	65
Application table for Nitrophoska perfect COMP BASF	66
Application table for Nitrozol Top Spiess Urania	67
Application table for NPK Raiffeisen	68
Application table for patent potash magnesia, Kali + Salz GmbH	69
Application table for Rasenstolz NPK, Spiess Urania	70
Application table for castor cake Agricolan (pellets) Günther	71
Application table for castor cake Agricolan (grist) Günther	72
Application table for superphosphate Donau Chemie	73
Application table for Basamid Compo	74
Application table for Basatop Sport COMPO BASF	75
Application table for Basatop Starter COMPO BASF	76
Application table for Floranid N32 COMPO BASF	77

Table	Page
Application table for Floranid NK COMPO BASF	78
Application table for Floranid Permanent COMPO BASF	79
Application table for Sportica K COMPO BASF	80

### 7.2.3 Application table for grit, sand, salt

- Application quantity in g/m<sup>2</sup>

	Grit					Sand (moist)					Salt				
	km/h					km/h					km/h				
	4	6	8	12	16	4	6	8	12	16	4	6	8	12	16
7											11	8	6	4	3
8											16	10	8	5	4
9											21	14	11	7	5
10	11	7	5	4	3	12	8	6	4	3	28	18	14	9	7
11	14	10	7	5	4	15	10	8	5	4	37	25	18	12	9
12	18	12	9	6	5	19	13	9	6	5	44	30	22	15	11
13	23	16	12	8	6	23	15	11	8	6	49	33	24	16	12
14	29	19	14	10	7	26	18	13	9	7	59	39	29	20	15
15	36	24	18	12	9	36	24	18	12	9	68	45	34	23	17
16	44	29	22	15	11	45	30	23	15	11	91	60	45	30	23
17	51	34	26	17	13	49	33	24	16	12	109	73	55	36	27
18	59	39	29	20	15	53	35	26	18	13	126	84	63	42	32
19	69	46	34	23	17	55	37	28	18	14	150	100	75	50	38
20	79	53	39	26	20	58	39	29	19	15	173	115	86	58	43
21	94	63	47	31	24	61	41	30	20	15	204	136	102	68	51
22	110	73	55	37	28	64	43	32	21	16	229	153	114	76	57
23	126	84	63	42	32	70	47	35	23	18					
24	143	95	71	48	36	77	51	38	26	19					
25	166	111	83	55	42	88	59	44	29	22					
26	190	127	95	63	48	99	66	49	33	25					
27	218	145	109	73	54	111	74	55	37	28					

	Grit					Sand (moist)					Salt				
28	245	163	123	82	61	123	82	61	41	31					
29	291	194	145	97	73	136	91	68	45	34					
30	336	224	158	112	84	149	100	75	50	37					
31	374	250	187	125	94	160	107	80	53	40					
32	413	275	206	138	103	171	114	86	57	43					
33						188	125	94	63	47					
34						205	137	103	68	51					
35						224	150	112	75	56					
36						244	163	122	81	61					
37						265	177	133	88	66					
38						287	191	143	96	72					
39						300	200	150	100	75					
40						313	209	157	104	78					
41						337	225	169	112	84					
42						361	241	181	120	90					
43						385	257	193	128	96					
44						409	273	204	136	102					

### 7.2.4 Application table for white mustard

- Application quantity in kg/ha

	PTO shaft 540 rpm = spreader shaft 15 rpm					PTO shaft 1000 rpm = spreader shaft 28 rpm				
	Handwheel setting 3 = spreader shaft 15 rpm					Handwheel setting 4.5 = spreader shaft 28 rpm				
	km/h					km/h				
	4	6	8	10	12	4	6	8	10	12
5	10	7	5	4	3	25	17	13	10	8
5.5	15	10	8	6	5	38	25	19	15	13
6	20	13	10	8	7	50	33	25	20	17
6.5	48	32	24	19	16	70	47	35	28	23
7	75	50	38	30	25	90	60	45	36	30
7.5	93	62	46	37	31					

### 7.2.5 Application table for lupins, yellow, white

- Application quantity in kg/ha

	PTO shaft 540 rpm = spreader shaft 15 rpm					PTO shaft 1000 rpm = spreader shaft 28 rpm				
	Handwheel setting 3 = spreader shaft 15 rpm					Handwheel setting 4.5 = spreader shaft 28 rpm				
	km/h					km/h				
	4	6	8	10	12	4	6	8	10	12
17	165	110	83	66	56	178	118	89	71	59
18	220	147	110	88	73	245	136	123	98	82
19	250	167	125	100	83	298	198	149	119	99
20	280	187	140	112	93	350	233	175	140	117
21	338	225	169	135	113	420	280	210	168	140
22	395	263	198	158	132	490	327	245	196	163
23	443	295	221	177	148	580	387	290	232	193
24	490	327	245	196	163	670	447	335	268	223
25	573	382	286	229	191					
26	655	437	328	262	218					

## 7.2.6 Application table for oil radish

- Application quantity in kg/ha

	PTO shaft 540 rpm = spreader shaft 15 rpm					PTO shaft 1000 rpm = spreader shaft 28 rpm				
	Handwheel setting 3 = spreader shaft 15 rpm					Handwheel setting 4.5 = spreader shaft 28 rpm				
	km/h					km/h				
	4	6	8	10	12	4	6	8	10	12
5	12	8	6	5	4	15	10	8	6	5
5.5	20	13	10	8	7	25	17	13	10	8
6	30	20	15	12	10	35	23	18	14	12
6.5	41	27	21	16	14	56	37	28	22	19
7	53	35	26	21	18	78	52	39	31	26
7.5	63	42	32	25	21	98	65	49	39	33
8	75	50	38	30	25					
8.5	93	62	47	37	31					

### 7.2.7 Application table for phacelia

- Application quantity in kg/ha

	PTO shaft 540 rpm = spreader shaft 15 rpm					PTO shaft 1000 rpm = spreader shaft 28 rpm				
	Handwheel setting 3 = spreader shaft 15 rpm					Handwheel setting 4.5 = spreader shaft 28 rpm				
	km/h					km/h				
	4	6	8	10	12	4	6	8	10	12
4						10	7	5	4	3
4.5	10	7	5	4	3	13	8	6	5	4
5	15	10	8	6	5	15	10	8	6	5
5.5	23	15	11	9	8	28	18	14	11	9
6	30	20	15	12	10	40	27	20	16	13
6.5	43	28	21	17	14					

### 7.2.8 Application table for oilseed rape

- Application quantity in kg/ha

	PTO shaft 540 rpm = spreader shaft 15 rpm					PTO shaft 1000 rpm = spreader shaft 28 rpm				
	Handwheel setting 3 = spreader shaft 15 rpm					Handwheel setting 4.5 = spreader shaft 28 rpm				
	km/h					km/h				
	4	6	8	10	12	4	6	8	10	12
3.5	15	10	8	6	5	15	10	8	6	5
4	20	13	10	8	7	45	30	23	18	15
4.5	38	25	19	15	13	68	45	34	27	23
5	59	39	29	23	20	93	62	46	37	31
5.5	79	53	40	32	26	116	78	58	47	39
6	100	67	50	40	33	140	93	70	56	47
6.5	131	87	56	52	44					

### 7.2.9 Application table for red clover

- Application quantity in kg/ha

	PTO shaft 540 rpm = spreader shaft 15 rpm					PTO shaft 1000 rpm = spreader shaft 28 rpm				
	Handwheel setting 3 = spreader shaft 15 rpm					Handwheel setting 4.5 = spreader shaft 28 rpm				
	km/h					km/h				
	4	6	8	10	12	4	6	8	10	12
3.5	15	10	8	6	5	15	10	8	6	5
4	20	13	10	8	7	45	30	23	18	15
4.5	38	25	19	15	13	68	45	34	27	23
5	59	39	29	23	20	93	62	46	37	31
5.5	79	53	40	32	26	116	78	58	47	39
6	100	67	50	40	33	140	93	70	56	47
6.5	131	87	56	52	44					

### 7.2.10 Application table for rye grass

- Application quantity in kg/ha

	PTO shaft 540 rpm = spreader shaft 15 rpm					PTO shaft 1000 rpm = spreader shaft 28 rpm				
	Handwheel setting 3 = spreader shaft 15 rpm					Handwheel setting 4.5 = spreader shaft 28 rpm				
	km/h					km/h				
	4	6	8	10	12	4	6	8	10	12
10						40	27	20	16	13
11	48	32	24	19	16	55	37	28	22	18
12	55	37	28	22	18	70	47	35	28	23
13	60	40	30	24	20	93	62	46	37	31
14	65	43	33	26	22	115	77	58	46	38
15	88	58	44	35	29	130	87	65	52	43
16	110	73	55	44	37	145	97	73	58	48
17	133	88	66	53	44	185	123	93	74	62
18	155	103	78	62	52					
19	165	110	83	66	55					
20	175	117	88	70	58					

### 7.2.11 Application table for vetches

- Application quantity in kg/ha

	PTO shaft 540 rpm = spreader shaft 15 rpm					PTO shaft 1000 rpm = spreader shaft 28 rpm				
	Handwheel setting 3 = spreader shaft 15 rpm					Handwheel setting 4.5 = spreader shaft 28 rpm				
	km/h					km/h				
	4	6	8	10	12	4	6	8	10	12
8	25	17	13	10	8	45	30	23	18	15
9	63	42	31	25	21	88	58	44	35	29
10	100	57	50	40	33	130	87	65	52	43
11	133	88	66	53	44	185	123	93	74	62
12	165	110	83	66	55	240	160	120	96	80
13	218	145	109	87	73	338	225	169	135	113
14	270	180	135	108	90	435	290	218	174	145
15	345	230	173	138	115					
16	420	280	210	168	140					

### 7.2.12 Application table for turnip rape

- Application quantity in kg/ha

	PTO shaft 540 rpm = spreader shaft 15 rpm					PTO shaft 1000 rpm = spreader shaft 28 rpm				
	Handwheel setting 3 = spreader shaft 15 rpm					Handwheel setting 4.5 = spreader shaft 28 rpm				
	km/h					km/h				
	4	6	8	10	12	4	6	8	10	12
5	25	17	13	10	8	25	17	13	10	8
5.5	38	25	19	15	13	38	25	19	15	13
6	50	33	25	20	17	75	50	38	30	25
6.5	70	47	35	28	23	98	65	49	39	33
7	90	60	45	36	30					

### 7.2.13 Application table for Agricorn, Günther Corufera GmbH

- Application quantity in kg/ha
- NPK

	PTO shaft 540 rpm = spreader shaft 15 rpm					PTO shaft 1000 rpm = spreader shaft 28 rpm				
	Handwheel setting 3 = spreader shaft 15 rpm					Handwheel setting 4.5 = spreader shaft 28 rpm				
	km/h					km/h				
	4	6	8	10	12	4	6	8	10	12
25						980	653	490	392	327
26						1090	727	545	436	363
27						1215	810	608	486	405
28						1340	893	670	536	447
29						1495	997	748	598	498
30	970	647	485	388	323	1650	1100	825	660	550
31	1118	745	559	447	373	1878	1252	939	751	626
32	1265	843	633	506	422	2105	1403	1053	842	702
33	1413	942	706	565	471	2333	1555	1166	933	778
34	1560	1040	780	524	520	2560	1707	1280	1024	853
35	1730	1153	865	692	577	2820	1880	1410	1128	940
36	1900	1267	950	760	633	3080	2053	1540	1232	1027
37	2135	1423	1068	854	712	3340	2227	1670	1336	1113
38	2370	1580	1185	948	790	3600	2400	1800	1440	1200
39	2560	1707	1280	1024	853	3825	2550	1913	1530	1275
40	2750	1833	1375	1100	917	4050	2700	2025	1620	1350
41	3018	2012	1509	1207	1006	4305	2870	2153	1722	1435
42	3285	2190	1643	1314	1095	4560	3040	2280	1824	1520
43	3593	2395	1796	1437	1198	4905	3270	2453	1962	1635
44	3900	2600	1950	1560	1300	5250	3500	2625	2100	1750
45	4253	2835	2126	1701	1418	5665	3777	2833	2266	1888
46	4605	3070	2303	1842	1535	6080	4053	3040	2432	2027
47	4903	3268	2451	1961	1634	6390	4260	3195	2556	2130

	PTO shaft 540 rpm = spreader shaft 15 rpm					PTO shaft 1000 rpm = spreader shaft 28 rpm				
48	5200	3467	2600	2080	1733	6700	4467	3350	2680	2233
49	5520	3680	2760	2208	1840	7085	4723	3543	2834	2362
50	5840	3893	2920	2336	1947	7470	4980	3735	2988	2490

### 7.2.14 Application table for prilled urea, SKW Piesteritz

- Application quantity in kg/ha
- Composition 46% N

	PTO shaft 540 rpm = spreader shaft 15 rpm					PTO shaft 1000 rpm = spreader shaft 28 rpm				
	Handwheel setting 3 = spreader shaft 15 rpm					Handwheel setting 4.5 = spreader shaft 28 rpm				
	km/h					km/h				
	4	6	8	10	12	4	6	8	10	12
6	60	40	30	24	20	75	50	38	30	25
7	100	67	50	40	33	125	83	63	50	42
8	140	93	70	56	47	175	117	88	70	58
9	210	140	105	84	70	275	183	138	110	92
10	280	187	140	112	93	375	250	188	150	125
11	370	247	185	148	123	473	315	236	189	158
12	460	307	230	184	153	570	380	285	228	190
13	603	402	301	241	201	723	482	361	289	241
14	745	497	373	298	248	875	583	438	350	292
15	878	585	439	351	293	1068	712	534	427	356
16	1010	673	505	404	337	1260	840	630	504	420
17	1205	803	603	482	402	1455	970	728	582	485
18	1400	933	700	560	467	1650	1100	825	660	550
19	1580	1053	790	632	527	1898	1265	949	759	633
20	1760	1173	880	704	587	2145	1430	1073	858	715
21	1990	1327	995	796	663					
22	2220	1480	1110	888	740					

### 7.2.15 Application table for calcium ammonium nitrate, Raiffeisen

- Application quantity in kg/ha
- Composition 27 % N

	PTO shaft 540 rpm = spreader shaft 15 rpm					PTO shaft 1000 rpm = spreader shaft 28 rpm				
	Handwheel setting 3 = spreader shaft 15 rpm					Handwheel setting 4.5 = spreader shaft 28 rpm				
	km/h					km/h				
	4	6	8	10	12	4	6	8	10	12
10	145	97	73	58	48	220	147	110	88	73
11	195	130	98	78	65	305	203	153	122	102
12	245	163	123	98	82	390	260	195	156	130
13	340	227	170	136	113	493	328	246	197	164
14	435	290	218	174	145	595	397	298	238	198
15	543	362	271	217	181	730	487	365	292	243
16	650	433	325	260	217	865	577	433	346	288
17	805	537	403	322	268	1030	687	515	412	343
18	960	640	480	384	320	1195	797	598	478	398
19	1103	735	551	441	368	1380	920	690	552	460
20	1245	830	623	498	415	1565	1043	783	626	522
21	1463	975	731	585	488	1743	1162	871	697	581
22	1680	1120	840	672	560	1920	1280	960	768	640
23	1885	1257	943	754	628	2205	1470	1103	882	735
24	2090	1393	1045	836	697	2490	1660	1245	996	830
25	2375	1583	1188	950	792					
26	2660	1773	1330	1064	887					

### 7.2.16 Application table for calcium cyanide, SKW Trostberg

- Application quantity in kg/ha
- Composition 19.8% N

	PTO shaft 540 rpm = spreader shaft 15 rpm					PTO shaft 1000 rpm = spreader shaft 28 rpm				
	Handwheel setting 3 = spreader shaft 15 rpm					Handwheel setting 4.5 = spreader shaft 28 rpm				
	km/h					km/h				
	4	6	8	10	12	4	6	8	10	12
10	300	200	150	120	100	420	280	210	168	140
11	388	258	194	155	129	565	377	283	226	188
12	475	317	238	190	158	710	473	355	284	237
13	600	400	300	240	200	865	577	433	346	288
14	725	483	363	290	242	1020	680	510	408	340
15	925	617	463	370	308	1230	820	615	492	410
16	1125	750	563	450	375	1440	960	720	576	480
17	1328	885	664	531	443	1700	1133	850	680	567
18	1530	1020	765	612	510	1960	1307	980	784	653
19	1795	1197	898	718	598	2225	1483	1113	890	742
20	2060	1373	1030	824	687	2490	1660	1245	996	830
21	2430	1620	1215	972	810	2835	1890	1418	1134	945
22	2800	1867	1400	1120	933	3180	2120	1590	1272	1060
23	3180	2120	1590	1272	1060	3600	2400	1800	1440	1200
24	3560	2373	1780	1424	1187	4020	2680	2010	1608	1340

### 7.2.17 Application table for converter lime

- Application quantity in kg/ha
- 45 % CaO

	PTO shaft 540 rpm = spreader shaft 15 rpm					PTO shaft 1000 rpm = spreader shaft 28 rpm				
	Handwheel setting 3 = spreader shaft 15 rpm					Handwheel setting 4.5 = spreader shaft 28 rpm				
	km/h					km/h				
	4	6	8	10	12	4	6	8	10	12
15						1345	897	673	538	448
16						1608	1072	804	643	536
17						1871	1247	936	748	624
18						2134	1423	1067	854	711
19						2397	1598	1199	959	799
20	1670	1113	835	668	557	2660	1773	1330	1064	887
21	1936	1291	968	774	645	3046	2031	1523	1218	1015
22	2202	1468	1101	881	734	3432	2288	1716	1373	1144
23	2468	1645	1234	987	823	3818	2545	1909	1527	1273
24	2734	1823	1367	1094	911	4204	2803	2102	1682	1401
25	3090	2060	1545	1236	1030	4700	3133	2350	1880	1567
26	3446	2297	1723	1378	1149	5196	3464	2598	2078	1732
27	3892	2595	1946	1557	1297	5802	3868	2901	2321	1934
28	4338	2892	2169	1735	1446	6408	4272	3204	2563	2136
29	4784	3189	2392	1914	1595	7014	4676	3507	2806	2338
30	5230	3487	2615	2092	1743	7620	5080	3810	3048	2540
31	5780	3853	2890	2312	1927	8454	5636	4227	3382	2818
32	6330	4220	3165	2532	2110	9288	6192	4644	3715	3096
33	6880	4587	3440	2752	2293	10122	6748	5061	4049	3374
34	7430	4953	3715	2972	2477	10956	7304	5478	4382	3652
35	8067	5378	4034	3227	2689	11955	7970	5978	4782	3985
36	8703	5802	4352	3481	2901					
37	9426	6284	4713	3770	3142					

	PTO shaft 540 rpm = spreader shaft 15 rpm					PTO shaft 1000 rpm = spreader shaft 28 rpm				
38	10149	6766	5075	4060	3383					
39	10872	7248	5436	4349	3624					
40	11595	7730	5798	4638	3865					
41	12450	8300	6225	4980	4150					

### 7.2.18 Application table for NPK MALTAFLOR

- Application quantity in kg/ha
- 45 % CaO

	PTO shaft 540 rpm = spreader shaft 15 rpm					PTO shaft 1000 rpm = spreader shaft 28 rpm				
	Handwheel setting 3 = spreader shaft 15 rpm					Handwheel setting 4.5 = spreader shaft 28 rpm				
	km/h					km/h				
	4	6	8	10	12	4	6	8	10	12
22	395	263	198	158	132	575	383	288	230	192
23	470	313	235	188	157	730	487	365	292	243
24	545	363	273	218	182	880	587	440	352	293
25	620	413	310	248	207	1040	693	520	416	347
26	695	463	348	278	232	1200	800	600	480	400
27	790	527	395	316	263	1350	900	675	540	450
28	890	593	445	356	297	1500	1000	750	600	500
29	995	663	498	398	332	1660	1107	830	664	553
30	1100	733	550	440	367	1820	1213	910	728	607
31	1250	833	625	500	417	2010	1340	1005	804	670
32	1400	933	700	560	467	2200	1467	1100	880	733
33	1585	1057	793	634	528	2405	1603	1203	962	802
34	1770	1180	885	708	590	2610	1740	1305	1044	870
35	1935	1290	968	774	645	2880	1920	1440	1152	960
36	2100	1400	1050	840	700	3150	2100	1575	1260	1050
37	2320	1547	1160	928	773	3443	2295	1721	1377	1148
38	2535	1690	1268	1014	845	3735	2490	1868	1494	1245
39	2767	1845	1384	1107	922	4043	2695	2022	1617	1348
40	3000	2000	1500	1200	1000	4350	2900	2175	1740	1450
41	3330	2220	1665	1332	1110	4675	3117	2338	1870	1558
42	3675	2450	1838	1470	1225	5000	3333	2500	2000	1667
43	3880	2587	1940	1552	1293	5375	3583	2688	2150	1792
44	4100	2733	2050	1640	1367	5750	3833	2875	2300	1917

	PTO shaft 540 rpm = spreader shaft 15 rpm					PTO shaft 1000 rpm = spreader shaft 28 rpm				
45	4435	2957	2218	1774	1478	6125	4083	3063	2450	2042
46	4770	3180	2385	1908	1590	6500	4333	3250	2600	2167
47	5135	3423	2568	2054	1712	6875	4583	3438	2750	2292
48	5500	3667	2750	2200	1833	7250	4833	3625	2900	2417
49	5930	3953	2965	2372	1977	7645	5097	3823	3058	2548
50	6360	4240	3180	2544	2120	8040	5360	4020	3216	2680

### 7.2.19 Application table for Maxiflor 92, finely ground, Maxit Kalkwerke

- Application quantity in kg/ha
- Composition 54 % CaO

	PTO shaft 540 rpm = spreader shaft 15 rpm					PTO shaft 1000 rpm = spreader shaft 28 rpm				
	Handwheel setting 3 = spreader shaft 15 rpm					Handwheel setting 4.5 = spreader shaft 28 rpm				
	km/h					km/h				
	4	6	8	10	12	4	6	8	10	12
35	1770	1180	885	708	590	2269	1513	1135	908	756
36	1866	1244	933	746	622	2451	1634	1226	980	817
37	1962	1308	981	785	654	2633	1755	1317	1053	878
38	2058	1372	1029	823	686	2815	1877	1408	1126	938
39	2154	1436	1077	862	718	2998	1998	1499	1199	999
40	2250	1500	1125	900	750	3180	2120	1590	1272	1060
41	2360	1573	1180	944	787	3471	2314	1736	1388	1157
42	2470	1647	1235	988	823	3762	2508	1881	1505	1254
43	2582	1721	1291	1033	861	4053	2702	2027	1621	1351
44	2694	1796	1347	1078	898	4344	2896	2172	1738	1448
45	2855	1903	1427	1142	952	4610	3073	2305	1844	1537
46	3015	2010	1508	1206	1005	4875	3250	2438	1950	1625
47	3225	2150	1613	1290	1075	5115	3410	2558	2046	1705
48	3435	2290	1718	1374	1145	5355	3570	2678	2142	1785
49	3645	2430	1823	1458	1215	5595	3730	2798	2238	1865
50	3855	2570	1928	1542	1285	5835	3890	2918	2334	1945

### 7.2.20 Application table for Nitrophoska perfect COMP BASF

- Application quantity in kg/ha
- Composition NPK 15- 5 - 20

	PTO shaft 540 rpm = spreader shaft 15 rpm					PTO shaft 1000 rpm = spreader shaft 28 rpm				
	Handwheel setting 3 = spreader shaft 15 rpm					Handwheel setting 4.5 = spreader shaft 28 rpm				
	km/h					km/h				
	4	6	8	10	12	4	6	8	10	12
10	175	117	88	70	58	250	167	125	100	83
11	233	155	116	93	78	335	223	168	134	112
12	290	193	145	116	97	420	280	210	168	140
13	355	237	178	142	118	535	357	268	214	178
14	420	280	210	168	140	650	433	325	260	217
15	535	357	268	214	178	805	537	403	322	268
16	650	433	325	260	217	960	640	480	384	320
17	788	525	394	315	263	1133	755	566	453	378
18	925	617	463	370	308	1305	870	653	522	435
19	1083	722	541	433	361	1553	1035	776	621	518
20	1240	827	620	496	413	1800	1200	900	720	600
21	1468	978	734	587	489	2050	1367	1025	820	683
22	1695	1130	848	678	565	2300	1533	1150	920	767
23	1973	1315	986	789	658	2660	1773	1330	1064	887
24	2250	1500	1125	900	750	3020	2013	1510	1208	1007
25	2625	1750	1313	1050	875	3360	2240	1680	1344	1120
26	3000	2000	1500	1200	1000					
27	3390	2260	1695	1356	1130					

### 7.2.21 Application table for Nitrozol Top Spiess Urania

- Application quantity in kg/ha
- Composition 38 % N

	PTO shaft 540 rpm = spreader shaft 15 rpm					PTO shaft 1000 rpm = spreader shaft 28 rpm				
	Handwheel setting 3 = spreader shaft 15 rpm					Handwheel setting 4.5 = spreader shaft 28 rpm				
	km/h					km/h				
	4	6	8	10	12	4	6	8	10	12
13	320	213	160	128	107	385	257	193	154	128
14	385	257	193	154	128	445	297	223	178	148
15	478	318	239	191	159	568	378	284	227	189
16	570	380	285	228	190	690	460	345	276	230
17	680	453	340	272	227	828	552	414	331	276
18	790	527	395	316	263	965	643	483	386	322
19	935	623	468	374	312	1113	742	556	445	371
20	1080	720	540	432	360	1260	840	630	504	420
21	1220	813	610	488	407	1475	983	738	590	492
22	1360	907	680	544	453	1690	1127	845	676	563
23	1555	1037	778	622	518	1865	1243	933	746	622
24	1750	1167	875	700	583	2040	1360	1020	816	680
25	1995	1330	998	798	665	2285	1523	1143	914	762
26	2240	1493	1120	896	747	2530	1687	1265	1012	843
27	2595	1730	1298	1038	865					

## 7.2.22 Application table for NPK Raiffeisen

- Application quantity in kg/ha
- Composition NPK 12 - 12 - 17

	PTO shaft 540 rpm = spreader shaft 15 rpm					PTO shaft 1000 rpm = spreader shaft 28 rpm				
	Handwheel setting 3 = spreader shaft 15 rpm					Handwheel setting 4.5 = spreader shaft 28 rpm				
	km/h					km/h				
	4	6	8	10	12	4	6	8	10	12
10	200	133	100	80	67	320	213	160	128	107
11	255	170	128	102	85	380	253	190	152	127
12	310	207	155	124	103	440	293	220	176	147
13	380	253	190	152	127	558	372	279	223	186
14	450	300	225	180	150	675	450	338	270	225
15	590	393	295	236	197	818	545	409	327	273
16	730	487	365	292	243	960	640	480	384	320
17	870	580	435	348	290	1133	755	566	453	378
18	1010	673	505	404	337	1305	870	653	522	435
19	1218	812	609	487	406	1555	1037	778	622	518
20	1425	950	713	570	475	1805	1203	903	722	602
21	1593	1062	796	637	531	2068	1378	1034	827	689
22	1760	1173	880	704	587	2330	1553	1165	932	777
23	2090	1393	1045	836	697	2690	1793	1345	1076	897
24	2420	1613	1210	968	807	3050	2033	1525	1220	1017
25	2735	1823	1368	1094	912	3500	2333	1750	1400	1167
26	3050	2033	1525	1220	1017	3950	2633	1975	1580	1317
27	3445	2297	1723	1378	1148	4375	2917	2188	1750	1458
28	3840	2560	1920	1536	1280					
29	4380	2920	2190	1752	1460					

### 7.2.23 Application table for patent potash magnesia, Kali + Salz GmbH

- Application quantity in kg/ha
- Composition 30 % K

	PTO shaft 540 rpm = spreader shaft 15 rpm					PTO shaft 1000 rpm = spreader shaft 28 rpm				
	Handwheel setting 3 = spreader shaft 15 rpm					Handwheel setting 4.5 = spreader shaft 28 rpm				
	km/h					km/h				
	4	6	8	10	12	4	6	8	10	12
10	145	97	73	58	48	195	130	98	78	65
11	205	137	103	82	68	273	182	136	109	91
12	265	177	133	106	88	350	233	175	140	117
13	325	217	163	130	108	443	295	221	177	148
14	385	257	193	154	128	535	357	268	214	178
15	475	317	238	190	158	648	432	324	259	216
16	565	377	283	226	188	760	507	380	304	253
17	673	448	336	269	224	910	607	455	364	303
18	780	520	390	312	260	1060	707	530	424	353
19	913	608	456	365	304	1240	827	620	496	413
20	1045	697	523	418	348	1420	947	710	568	473
21	1203	802	601	481	401	1635	1090	818	654	545
22	1360	907	680	544	453	1850	1233	925	740	617
23	1550	1033	775	620	517	2095	1397	1048	838	698
24	1740	1160	870	696	580	2340	1560	1170	936	780
25	2025	1350	1013	810	675	2685	1790	1343	1074	895
26	2310	1540	1155	924	770	3030	2020	1515	1212	1010
27	2625	1750	1313	1050	875	3495	2330	1748	1398	1165
28	2940	1960	1470	1176	980	3960	2640	1980	1584	1320
29	3360	2240	1680	1344	1120					
30	3780	2520	1890	1512	1260					

### 7.2.24 Application table for Rasenstolz NPK, Spiess Urania

- Application quantity in kg/ha
- Composition NPK 20 - 6 - 18 + 2

	PTO shaft 540 rpm = spreader shaft 15 rpm					PTO shaft 1000 rpm = spreader shaft 28 rpm				
	Handwheel setting 3 = spreader shaft 15 rpm					Handwheel setting 4.5 = spreader shaft 28 rpm				
	km/h					km/h				
	4	6	8	10	12	4	6	8	10	12
10	165	110	83	66	55	330	220	165	132	110
11	248	165	124	99	83	438	292	219	175	146
12	330	220	165	132	110	545	363	273	218	182
13	418	278	209	167	139	648	432	324	259	216
14	505	337	253	202	168	750	500	375	300	250
15	620	413	310	248	207	880	587	440	352	293
16	735	490	368	294	245	1010	673	505	404	337
17	883	588	441	353	294	1180	787	590	472	393
18	1030	687	515	412	343	1350	900	675	540	450
19	1213	808	606	485	404	1588	1058	794	635	529
20	1395	930	698	558	465	1825	1217	913	730	608
21	1603	1068	801	641	534	2038	1358	1019	815	679
22	1810	1207	905	724	603	2250	1500	1125	900	750
23	2010	1340	1005	804	670	2550	1700	1275	1020	850
24	2210	1473	1105	884	737					

### 7.2.25 Application table for castor cake Agricolan (pellets) Günther

- Application quantity in kg/ha
- Composition 5 % N

	PTO shaft 540 rpm = spreader shaft 15 rpm					PTO shaft 1000 rpm = spreader shaft 28 rpm				
	Handwheel setting 3 = spreader shaft 15 rpm					Handwheel setting 4.5 = spreader shaft 28 rpm				
	km/h					km/h				
	4	6	8	10	12	4	6	8	10	12
32						1200	800	600	480	400
33						1360	907	680	544	453
34						1520	1013	760	608	507
35						1690	1127	845	676	563
36	1163	775	582	465	388	1860	1240	930	744	620
37	1274	849	637	510	425	2055	1370	1028	822	685
38	1385	923	693	554	462	2250	1500	1125	900	750
39	1493	995	746	597	498	2470	1647	1235	988	823
40	1600	1067	800	640	533	2690	1793	1345	1076	897
41	1715	1143	858	686	572	2915	1943	1458	1166	972
42	1830	1220	915	732	610	3140	2093	1570	1256	1047
43	2033	1355	1016	813	678	3325	2217	1663	1330	1108
44	2235	1490	1118	894	745	3510	2340	1755	1404	1170
45	2438	1625	1219	975	813	3740	2493	1870	1496	1247
46	2640	1760	1320	1056	880	3970	2647	1985	1588	1323
47	2845	1897	1423	1138	948	4115	2743	2058	1646	1372
48	3050	2033	1525	1220	1017	4260	2840	2130	1704	1420
49	3255	2170	1628	1302	1085	4470	2980	2235	1788	1490
50	3460	2307	1730	1384	1153	4680	3120	2340	1872	1560

### 7.2.26 Application table for castor cake Agricolan (grist) Günther

- Application quantity in kg/ha
- Composition 5 % N

	PTO shaft 540 rpm = spreader shaft 15 rpm					PTO shaft 1000 rpm = spreader shaft 28 rpm				
	Handwheel setting 3 = spreader shaft 15 rpm					Handwheel setting 4.5 = spreader shaft 28 rpm				
	km/h					km/h				
	4	6	8	10	12	4	6	8	10	12
26	1620	1080	810	648	540	965	643	483	386	322
27	1835	1223	918	734	612	1188	792	594	475	396
28	2050	1367	1025	820	683	1410	940	705	564	470
29	2265	1510	1133	906	755	1855	1237	928	742	618
30	2480	1653	1240	992	827	2300	1533	1150	920	767
31	2850	1900	1425	1140	950	2698	1798	1349	1079	899
32	3220	2147	1610	1288	1073	3095	2063	1548	1238	1032
33	3590	2393	1795	1436	1197	3628	2418	1814	1451	1209
34	3960	2640	1980	1584	1320	4160	2773	2080	1664	1387
35	4300	2867	2150	1720	1433	4650	3100	2325	1860	1550
36	4640	3093	2320	1856	1547	5140	3427	2570	2056	1713
37	4980	3320	2490	1992	1660	5540	3693	2770	2216	1847
38	5320	3547	2660	2128	1773	5940	3960	2970	2376	1980
39	5903	3935	2951	2361	1968	6480	4320	3240	2592	2160
40	6485	4323	3243	2594	2162	7020	4680	3510	2808	2340
41	7068	4712	3534	2827	2356	7560	5040	3780	3024	2520
42	7650	5100	3825	3060	2550	8100	5400	4050	3240	2700
43	8498	5665	4249	3399	2833	8790	5860	4395	3516	2930

### 7.2.27 Application table for superphosphate Donau Chemie

- Application quantity in kg/ha
- Composition 18 % P

	PTO shaft 540 rpm = spreader shaft 15 rpm					PTO shaft 1000 rpm = spreader shaft 28 rpm				
	Handwheel setting 3 = spreader shaft 15 rpm					Handwheel setting 4.5 = spreader shaft 28 rpm				
	km/h					km/h				
	4	6	8	10	12	4	6	8	10	12
10	160	107	80	64	53	260	173	130	104	87
11	240	160	120	96	80	333	222	166	133	111
12	320	213	160	128	107	405	270	203	162	135
13	400	267	200	160	133	503	335	251	201	168
14	480	320	240	192	160	600	400	300	240	200
15	565	377	283	226	188	715	477	358	286	238
16	650	433	325	260	217	830	553	415	332	277
17	798	532	399	319	266	980	653	490	392	327
18	945	630	473	378	315	1130	753	565	452	377
19	1073	715	536	429	358	1288	858	644	515	429
20	1200	800	600	480	400	1445	963	723	578	482
21	1445	963	723	578	482	1698	1132	849	679	566
22	1690	1127	845	676	563	1950	1300	975	780	650
23	1910	1273	955	764	637					

## 7.2.28 Application table for Basamid Compo

- Application quantity in kg/ha

	PTO shaft 540 rpm = spreader shaft 15 rpm					PTO shaft 1000 rpm = spreader shaft 28 rpm				
	Handwheel setting 3 = spreader shaft 15 rpm					Handwheel setting 4.5 = spreader shaft 28 rpm				
	km/h					km/h				
	4	6	8	10	12	4	6	8	10	12
6	205	137	103	82	68	235	157	118	94	78
7	285	190	143	114	95	290	193	145	116	97
8	365	243	183	146	122	350	233	175	140	117
9	460	307	230	184	153	475	317	238	190	158
10	560	373	280	224	187	600	400	300	240	200
11	710	473	355	284	237	735	490	368	294	245
12	850	567	425	340	283	870	580	435	348	290
13	1050	700	525	420	350	1090	727	545	436	363
14	1250	833	625	500	417	1310	873	655	524	437
15	1610	1073	805	644	537	1670	1113	835	668	557

### 7.2.29 Application table for Basatop Sport COMPO BASF

- Application quantity in kg/ha
- Composition PK 20 - 5 - 10 + 3 % MgO

	PTO shaft 540 rpm = spreader shaft 15 rpm					PTO shaft 1000 rpm = spreader shaft 28 rpm				
	Handwheel setting 3 = spreader shaft 15 rpm					Handwheel setting 4.5 = spreader shaft 28 rpm				
	km/h					km/h				
	4	6	8	10	12	4	6	8	10	12
10	90	60	45	36	30	150	100	75	60	50
11	145	97	73	58	48	241	160	120	96	80
12	200	133	100	80	67	331	221	166	133	110
13	258	172	129	103	86	421	280	210	168	140
14	315	210	158	126	105	510	340	255	204	170
15	395	263	198	158	132	641	427	320	256	214
16	475	317	238	190	158	771	514	386	309	257
17	600	400	300	240	200	917	611	458	367	306
18	725	483	363	290	242	1063	708	531	425	354
19	850	567	425	340	283	1244	829	622	498	415
20	975	650	488	390	325	1425	950	713	570	475
21	1175	783	588	470	392	1656	1104	828	663	552
22	1375	917	688	550	458	1888	1258	944	755	629
23	1600	1067	800	640	533	2156	1438	1078	863	719
24	1825	1217	913	730	608	2425	1617	1213	970	808
25	2100	1400	1050	840	700	2781	1854	1391	1113	927

### 7.2.30 Application table for Basatop Starter COMPO BASF

- Application quantity in kg/ha
- Composition PK 19 - 25 - 5 + 2 % MgO

	PTO shaft 540 rpm = spreader shaft 15 rpm					PTO shaft 1000 rpm = spreader shaft 28 rpm				
	Handwheel setting 3 = spreader shaft 15 rpm					Handwheel setting 4.5 = spreader shaft 28 rpm				
	km/h					km/h				
	4	6	8	10	12	4	6	8	10	12
10	70	47	35	28	23	105	70	53	42	35
11	105	70	53	42	35	178	118	89	71	59
12	141	94	70	56	47	250	167	125	100	83
13	177	118	89	71	59	326	218	163	131	109
14	214	143	107	86	71	403	269	201	161	134
15	316	211	158	127	105	504	336	252	202	168
16	419	279	209	168	140	605	403	303	242	202
17	525	350	263	210	175	753	502	376	301	251
18	631	421	316	253	210	900	600	450	360	300
19	791	527	395	316	264	1050	700	525	420	350
20	950	633	475	380	317	1200	800	600	480	400
21	1138	758	569	455	379	1400	933	700	560	467
22	1325	883	663	530	442	1600	1067	800	640	533
23	1538	1025	769	615	513	1838	1225	919	735	613
24	1750	1167	875	700	583	2075	1383	1038	830	692
25	2025	1350	1013	810	675	2381	1588	1191	953	794

### 7.2.31 Application table for Floranid N32 COMPO BASF

- Application quantity in kg/ha

	PTO shaft 540 rpm = spreader shaft 15 rpm					PTO shaft 1000 rpm = spreader shaft 28 rpm				
	Handwheel setting 3 = spreader shaft 15 rpm					Handwheel setting 4.5 = spreader shaft 28 rpm				
	km/h					km/h				
	4	6	8	10	12	4	6	8	10	12
10	70	47	35	28	23	105	70	53	42	35
11	105	70	53	42	35	178	118	89	71	59
12	141	94	70	56	47	250	167	125	100	83
13	177	118	89	71	59	326	218	163	131	109
14	214	143	107	86	71	403	269	201	161	134
15	316	211	158	127	105	504	336	252	202	168
16	419	279	209	168	140	605	403	303	242	202
17	525	350	263	210	175	753	502	376	301	251
18	631	421	316	253	210	900	600	450	360	300
19	791	527	395	316	264	1050	700	525	420	350
20	950	633	475	380	317	1200	800	600	480	400
21	1138	758	569	455	379	1400	933	700	560	467
22	1325	883	663	530	442	1600	1067	800	640	533
23	1538	1025	769	615	513	1838	1225	919	735	613
24	1750	1167	875	700	583	2075	1383	1038	830	692
25	2025	1350	1013	810	675	2381	1588	1191	953	794

**7.2.32 Application table for Floranid NK COMPO BASF**

- Application quantity in kg/ha
- Composition NK 14 - 19 + 3 % MgO

	PTO shaft 540 rpm = spreader shaft 15 rpm					PTO shaft 1000 rpm = spreader shaft 28 rpm				
	Handwheel setting 3 = spreader shaft 15 rpm					Handwheel setting 4.5 = spreader shaft 28 rpm				
	km/h					km/h				
	4	6	8	10	12	4	6	8	10	12
10	138	92	69	55	46	183	122	92	73	61
11	218	145	109	87	73	285	190	143	114	95
12	303	202	151	121	101	388	258	194	155	129
13	388	258	194	155	129	488	325	244	195	163
14	473	315	236	189	158	589	393	294	236	196
15	618	412	309	247	206	764	509	382	306	255
16	764	509	382	306	255	939	626	470	376	313
17	939	626	470	376	313	1148	765	574	459	383
18	1115	743	558	446	372	1356	904	678	543	452
19	1290	860	645	516	430	1569	1046	785	628	523
20	1465	977	733	586	488	1783	1188	891	713	594
21	1706	1138	853	683	569	2048	1365	1024	819	683
22	1948	1298	974	779	649	2313	1542	1156	925	771
23	2189	1459	1094	876	730	2578	1718	1289	1031	859
24	2430	1620	1215	972	810	2843	1895	1421	1137	948
25	2771	1848	1386	1109	924	3296	2198	1648	1319	1099

### 7.2.33 Application table for Floranid Permanent COMPO BASF

- Application quantity in kg/ha
- Composition PK 16 - 7 - 15 + 2 % MgO

	PTO shaft 540 rpm = spreader shaft 15 rpm					PTO shaft 1000 rpm = spreader shaft 28 rpm				
	Handwheel setting 3 = spreader shaft 15 rpm					Handwheel setting 4.5 = spreader shaft 28 rpm				
	km/h					km/h				
	4	6	8	10	12	4	6	8	10	12
10	83	56	42	33	28	113	75	56	45	38
11	104	69	52	42	35	189	126	95	76	63
12	125	83	63	50	42	266	178	133	107	89
13	164	109	82	66	55	343	229	172	137	114
14	203	135	101	81	68	420	280	210	168	140
15	326	218	163	131	109	541	361	271	217	180
16	450	300	225	180	150	663	442	331	265	221
17	569	379	284	228	190	806	538	403	323	269
18	688	458	344	275	229	950	633	475	380	317
19	850	567	425	340	283	1119	746	559	448	373
20	1013	675	506	405	338	1288	858	644	515	429
21	1206	804	603	483	402	1506	1004	753	603	502
22	1400	933	700	560	467	1725	1150	863	690	575
23	1588	1058	794	635	529	1938	1292	969	775	646
24	1775	1183	888	710	592	2150	1433	1075	860	717
25	2044	1363	1022	818	681	2456	1638	1228	983	819

### 7.2.34 Application table for Sportica K COMPO BASF

- Application quantity in kg/ha
- Composition NK 30 - 10 + 3 % MgO

	PTO shaft 540 rpm = spreader shaft 15 rpm					PTO shaft 1000 rpm = spreader shaft 28 rpm				
	Handwheel setting 3 = spreader shaft 15 rpm					Handwheel setting 4.5 = spreader shaft 28 rpm				
	km/h					km/h				
	4	6	8	10	12	4	6	8	10	12
10	45	30	23	18	15	68	45	34	27	23
11	83	55	41	33	28	115	77	58	46	38
12	120	80	60	48	40	163	108	81	65	54
13	158	105	79	63	53	209	139	104	84	70
14	195	130	98	78	65	255	170	128	102	85
15	254	169	127	102	85	328	218	164	131	109
16	313	208	156	125	104	400	267	200	160	133
17	394	263	197	158	131	488	325	244	195	163
18	475	317	238	190	158	575	383	288	230	192
19	569	379	284	228	190	663	442	331	265	221
20	663	442	331	265	221	750	500	375	300	250
21	794	529	397	318	265	888	592	444	355	296
22	925	617	463	370	308	1025	683	513	410	342
23	1063	708	531	425	354	1163	775	581	465	388
24	1200	800	600	480	400	1300	867	650	520	433
25	1381	921	691	553	460	1488	992	744	595	496

## 8 Calibration test

For precise control of the discharge amount, we recommend running a new calibration test every time the spreading material type is changed.

Execute the calibration:

- Before spreading for the first time
- If the spreading material quality has changed significantly (moisture, high dust content, granulate damage)
- If a new spreading material is used

The calibration test must be conducted while the drive is running at a standstill or during travel over a test track.

### **NOTICE!**

**For universal hopper spreaders UKS with QUANTRON A the calibration test is performed using the QUANTRON-A control unit.**

The calibration test is described in a separate operator's manual for the control unit QUANTRON A. This operator's manual is an integral part of the control unit QUANTRON A.

### 8.1 Calculate the maximum spreading distance

The maximum spreading distance depends on the following points:

- The quantity of spreading material (g) carried
- The grit density ( $\text{g}/\text{m}^2$ )
- The spreading width (m)

**Formula:**

Hopper contents/application density = Spreading distance at 1 m spreading width

**Example:**

- $300000 \text{ g} / 30 \text{ g}/\text{m}^2 = 10000 \text{ m}^2 = 10 \text{ km}$  spreading distance
- Spreading distance at 1.20 m spreading width:  $10000 \text{ m} / 1.20 = 8333 \text{ m}$
- If the hopper contents are 300000 g, an application density of 30  $\text{g}/\text{m}^2$  and a spreading width of 1.20 m means you can perform spreading for a distance of 8333 m.

### 8.2 Determining the target discharge rate per minute

To calculate the nominal discharge rate per minute, you will require the following:

- the forward speed,
- the working width,
- the desired application rate.

**8.2.1 Example 1: Sand, salt and grit (g/min)**

Forward speed	3 km/h
Working width	1.20 m
Desired application rate	50 g/m <sup>2</sup>
Target output quantity	? kg/min

- Formula:

$$\text{Nominal discharge rate:} = \frac{\text{Forward speed} \times \text{working width} \times \text{application rate}}{60}$$

$$\text{Example:} \quad \frac{3\text{km/h} \times 1.20\text{m} \times 50\text{g/m}^2}{60} = 3 \text{ kg/min}$$

*3 kg spreading medium must be discharged per minute.*

**8.2.2 Example 2: Spreading material (kg/min)**

Forward speed	8 km/h
Working width	1.50 m
Desired application rate	300kg/ha
Target output quantity	? kg/min

- Formula:

$$\text{Nominal discharge rate:} = \frac{\text{Forward speed} \times \text{working width} \times \text{application rate}}{600}$$

$$\text{Example:} \quad \frac{3 \text{ km/h} \times 1.5 \text{ m} \times 300 \text{ kg/ha}}{600} = 6 \text{ kg/min}$$

*6 kg spreading medium must be discharged per minute.*

## 8.3 Implementing the calibration test

### WARNING!

#### Risk of injury due to chemicals

Escaping spreading material may lead to injury to eyes and nasal mucous membranes.

- ▶ Wear safety goggles during calibration.
- ▶ Follow the manufacturer's warnings when handling chemicals. Wear the recommended personal protective equipment (PPE).
- ▶ Before running the calibration test, ensure that all people leave the hazard zone of the machine.

#### Requirements

- The metering slide is closed.
- Drive and roller engine are switched off and locked to prevent unauthorized starting.
- An adequately sized hopper is ready for collecting the discharged spreading material. The hopper's empty weight is known.
- Using the spreading material chart, the pre-set values for the metering slide stop are determined and known.
- There is sufficient spreading material in the hopper.



Select the calibration time to obtain the maximum possible spreading material discharge quantity. The higher the quantity, the higher the precision of the measurement (e.g., Nominal output rate: 10 kg/min, calibration test time: 3 min, used spreading material quantity: 30 kg).

### DANGER!

#### Risk of injury due to rotating machine parts

Any contact with rotating machine parts (drive shaft, agitator shaft) may lead to bruises, abrasions, and crushing injuries. Body parts or objects may be caught or pulled in.

- ▶ Always stay outside the area of rotating components while the machine is running.
- ▶ Operate the metering slide from the seat in the roller only when the drive shaft is rotating.
- ▶ Before running the calibration test, ensure that all people leave the hazard zone of the machine.

**Implementation:**

- ▶ Fill the machine.
- ▶ Place a foil or a hopper for collecting the spreading material under the machine.
- ▶ Set the metering slide stop to the scale value from the spreading material chart.
- ▶ Switch on the roller.
- ▶ Start the agitator shaft.
- ▶ Set the agitator shaft speed in accordance with the information in the spreading material chart.
- ▶ Open the metering slide for the calibration test time specified before (e.g., 60 seconds).
- ▶ Close the metering slide when this time has elapsed.
- ▶ Switch off the drive and the roller. Remove the ignition key.
- ▶ Determine the collected weight.
- ▶ Compare the actual quantity with the target quantity.

Actual quantity = nominal quantity	The adjustment lever at the metering slide is set correctly. End calibration test.
Actual quantity < nominal quantity	Set the adjustment lever at the metering slide to a higher scale value and repeat the calibration test. . Repeat the calibration test
Actual quantity > nominal quantity	Set the adjustment lever at the metering slide to a lower scale value. Repeat the calibration test

## 9 Valuable instructions for spreading work

### 9.1 General recommendations

The modern technology and design of our machines and exhaustive, continuous testing in the factory's spreading material test system ensure that you will have a perfect spreading pattern.

In spite of the care taken during machine manufacture, deviations in application or other faults are possible even with designated usage.

Reasons for this may be:

- Changes in the physical properties of the spreading material (such as variable grain size distribution, variable density, grain size and surface, and moisture)
- Clumping and damp spreading material
- Wind drift: stop spreading at high wind speeds.
- Blockages or bridge formation (e.g., due to foreign objects, bag residue, wet spreading material).
- Uneven ground
- Abrasion of wear parts, e.g., agitator, spreading vanes, outlet.
- Damage from external causes
- Poor cleaning and care for preventing corrosion
- Incorrect drive speeds and forward speeds
- Calibration test has not been carried out or calibration test has been carried out with incorrect values (e.g., incorrect PTO speed)
- Incorrect machine settings



Cleaning the machine after each use prevents deposits at the hopper base. You can thus reduce the wear of the agitator and increase the operational reliability of your machine.

Pay close attention to the machine settings. Even a slightly incorrect setting may have a significant adverse effect on the spreading pattern. Therefore check the machine for correct operation and for sufficiently accurate application rate (perform a calibration test) before each time you start to use it and also whilst it is in use.

Claims for damage other than to the universal hopper spreader itself will not be accepted.

**This also means that no liability will be accepted for damage resulting from spreading errors.**

### 9.2 Procedure for spreading the spreading material

The intended use of the universal hopper spreader includes compliance with the operating, maintenance conditions and service conditions in accordance with the manufacturer's specifications. Spreading therefore always includes preparation and cleaning/maintenance.

**! WARNING!**

**Risk of injury due to spreading material**

Ejected spreading material may cause injury.

- ▶ Ensure that nobody is present in the hazard zone.

- Perform spreading work in accordance with the procedure set out below.

Preparation	• Attach the machine at the tractor	<i>Chapter 6.5 - Installing the machine at the tractor - Page 32</i>
	• Close the metering slide	
	• Fill the hopper with spreading material	<i>Chapter 6.8 - Filling the machine - Page 38</i>
	• Perform a calibration test	<i>Chapter 8 - Calibration test - Page 81</i>
	• Adjust the application quantity	<i>Chapter 7.1 - Setting the spreading quantity - Page 41</i>

Performing spreading	• Travel to the spreading location	
	• Switch on the drive.	
	• Open the metering slide and start spreading operations.	
	• Finish spreading operations and close the metering slide.	
	• Turn off the drive.	
	• Discharge any residual material	<i>Chapter 9.3 - Discharging residual material - Page 87</i>

Cleaning / Maintenance	<ul style="list-style-type: none"> <li>• Open the metering slides</li> </ul>	
	<ul style="list-style-type: none"> <li>• Remove the machine from the tractor.</li> </ul>	<i>Chapter 6.9 - Parking and unhitching the machine - Page 39</i>
	<ul style="list-style-type: none"> <li>• Cleaning and maintenance:</li> </ul>	<i>Chapter 10 - Maintenance and service - Page 90</i>

**NOTICE!**

In order to avoid mealy material being blown away, we recommend fitting a windshield.

- ▶ See Chapter 12 - Optional equipment is available - Page 96

## 9.3 Discharging residual material

### 9.3.1 Emptying the hopper - UKS 80 to UKS 120

**! WARNING!****Risk of injury due to rotating machine parts**

Rotating machine components (universal drive shaft, hubs) may catch and pull-in body parts or objects. Contact with rotating machine components may cause bruises, abrasions and crushing injuries.

- ▶ Always stay outside the area of rotating hubs while the machine is running.
- ▶ When the drive shaft is rotating, the metering slides are to be operated from the tractor seat at all times.
- ▶ Ensure that nobody is present in the hazard zone of the machine.

To maintain the value of your universal hopper spreader, we recommend it should be emptied immediately after each time it is used.

**Instructions for completely discharging the residual material:**

The universal hopper spreader is equipped with a hinged base to the hopper.

- ▶ Release the star knobs.
- ▶ Swing the hinged base to the hopper away downwards. Swing the hinged base to the hopper away downwards.
- ▶ Any remaining spreading material can be removed with a gentle water jet when cleaning the machine;.

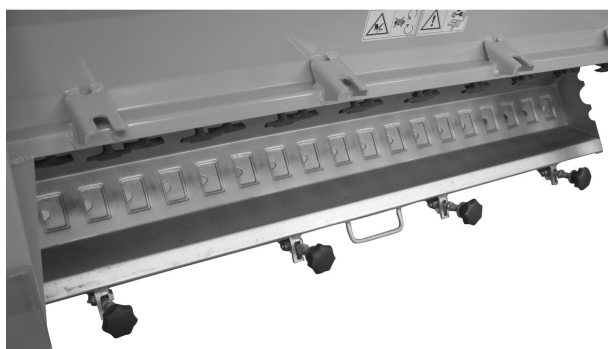

Fig. 16: Quick emptying of UKS 80 to UKS 120

### 9.3.2 Emptying the hopper - UKS 150 GB to UKS 300 GB

#### **⚠ WARNING!**

##### **Risk of injury due to rotating machine parts**

Rotating machine components (universal drive shaft, hubs) may catch and pull-in body parts or objects. Contact with rotating machine components may cause bruises, abrasions and crushing injuries.

- ▶ Always stay outside the area of rotating hubs while the machine is running.
- ▶ When the drive shaft is rotating, the metering slides are to be operated from the tractor seat at all times.
- ▶ Ensure that nobody is present in the hazard zone of the machine.

To maintain the value of your universal hopper spreader, we recommend it should be emptied immediately after each time it is used.

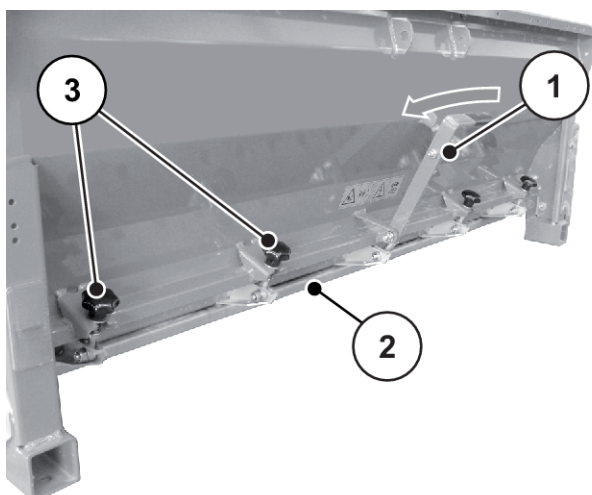

Fig. 17: Quick emptying of fertilizer spreaders UKS GB. Release the star knobs.

- [1] Operating lever
- [2] Hopper base

- [3] Star knobs

#### **Instructions for completely discharging the residual material:**

The universal hopper spreader is equipped with a hinged base to the hopper.

- ▶ Release the star knobs [3].
- ▶ Using the operating lever [2], swing the hinged base [1] to the hopper away downwards.
- ▶ Any remaining spreading material can be removed with a gentle water jet when cleaning the machine;.

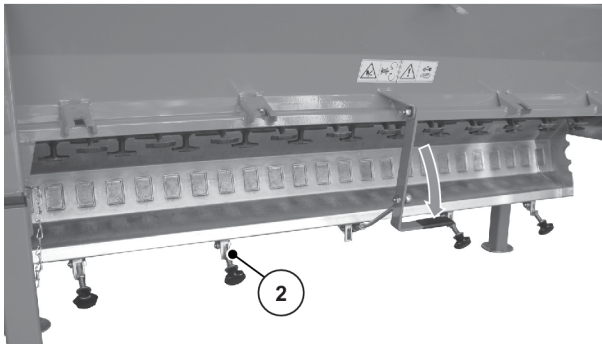

*Fig. 18: Quick emptying of fertilizer spreaders UKS GB, Swing the hinged base to the hopper away downwards.*

## 10 Maintenance and service

### 10.1 Safety



Please note the warnings in the chapter 3 *Safety*

Take **particular note of the instructions** in the section. *3.8 Maintenance and service*

Observe the following instructions in particular:

- Welding and work on the electrical and hydraulic systems is to be carried out by qualified technicians only.
- There is a **risk of tipping** when working at the lifted machine. Always secure the machine using suitable supports.
- Always use **both** eyelets in the hopper for lifting the machine by means of hoisting gear.
- There is a risk of **crushing and shearing** at power-operated components. Make sure that there is no one in close proximity to the moving parts during maintenance.
- Spare parts must at least comply with the technical standards specified by the manufacturer. This is assured with original spare parts.
- Before starting any cleaning, maintenance, or repair work, and when troubleshooting, switch off the tractor's engine, remove the ignition key, and wait until all moving parts of the machine have come to a stop.
- By controlling the machine with an operating unit, additional risks and hazards due to externally operated components may arise.
  - Disconnect the power supply between the tractor and the machine.
  - Disconnect the power supply cable from the battery.
- Repairs may **ONLY be carried out by instructed and authorized workshops**.

#### **DANGER!**

##### **Danger of injury due to running engine**

Working on the machine with the engine running may result in serious injury caused by mechanical components and escaping fertilizer.

- ▶ Wait until all moving parts have come to a complete stop before making any adjustments or performing maintenance work.
- ▶ Switch off the tractor engine.
- ▶ Remove the ignition key.
- ▶ Ensure that nobody is present **in the hazard zone**.

## 10.2 Wear parts and screw connections

### 10.2.1 Checking wear parts

Wear parts are: **Agitator shaft, agitator fingers, hopper base, discharge opening, hydraulic hoses.**

- Check the wear parts.
- Check the ball bearings for the agitator shaft.

If these parts show signs of wear, deformation or perforation they must be replaced. Otherwise, the spreading pattern will not be correct.

The durability of wear parts depends, among other things, on the material being spread.

### 10.2.2 Checking the bolted connections

Screw connections have been tightened to the specified torque and locked at the factory. Vibration and shaking can loosen bolted connections, particularly during the first few hours of operation.

- After the first 30 hours of operation, check all the bolted connections on your new machine for tightness.
- Regularly, and at least every 250 operating hours, check all the bolted connections on your machine for tightness.

Some components are mounted with self-locking nuts. When fitting these components, **always use new self-locking** nuts.

## 10.3 Cleaning

To maintain the value of your machine, we recommend that you clean it after each time it is used.

In particular, observe the following instructions on cleaning:

- Clean the slide guide area only from below.
- Clean oiled machines only at washing points fitted with an oil separator.
- When cleaning with high-pressure water, never aim the water jet directly at warning signs, electrical equipment, hydraulic components, and plain bearings.

After the machine has been cleaned, we recommend that you treat the **dry** machine, **especially the stainless steel parts**, with an environmentally friendly anti-corrosion agent.

You can order a suitable polishing kit from an authorized dealer, to address any rust spots.

## 10.4 Check the agitator shaft for wear

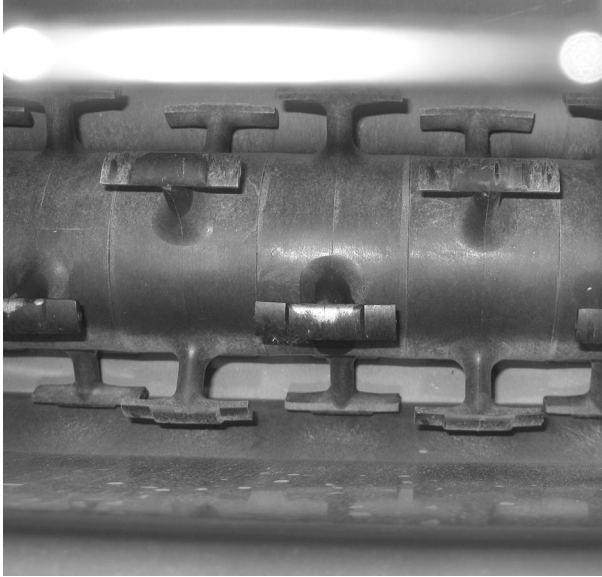

*Fig. 19: Check the agitator fingers for wear*

As long as the following points are satisfied, you can continue to use the agitator shaft.

- The T shape of the agitator fingers is clearly identifiable.
- The agitator fingers must slide over the spreading base.

*If that is not the case, the agitator fingers must be replaced.*



Entrust **ONLY** your dealer or specialist workshop with the task of replacing the agitator shaft.

### 10.4.1 Check the chain for wear and tension

- ▶ Regularly check the chain for wear and sufficient tension.
  - ▷ Replace the chain as necessary.
  - ▷ Use the chain tensioning roller to tension the chain.

## 10.5 Transmission oil

### 10.5.1 Quantities and types

The gearbox is filled with approx. **0.4 l** of C-LP 460 gear oil.



Use only one type of oil.

**Never mix different types of oil.**

### 10.5.2 Checking the oil level, changing the oil

Under normal operating conditions, the gearbox does not need lubrication. However, we recommend changing the oil **after 10 years**.

A shorter oil change interval is recommended if spreading materials with high dust content are used and if the spreader is frequently cleaned.

#### **⚠ CAUTION!**

##### **Environmentally responsible disposal of used oil**

If used oil gets into the ground water it poses a hazard for people and the environment.

- ▶ Dispose of used oil according to local regulations.

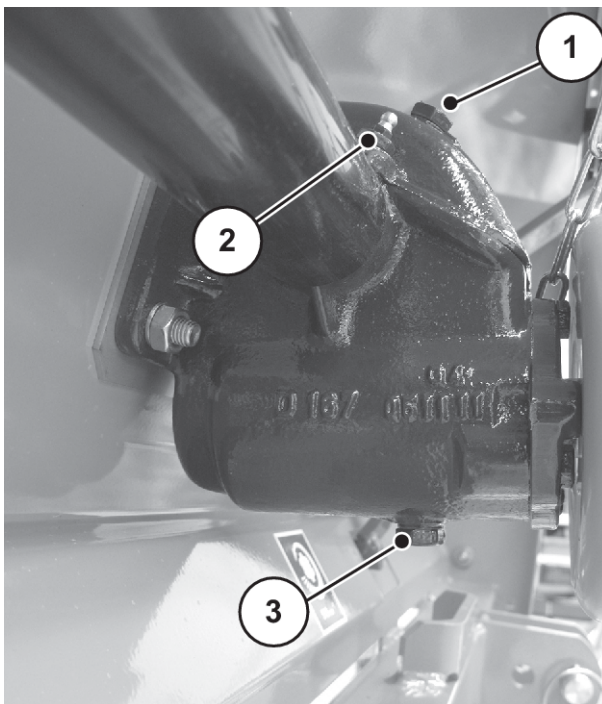

*Fig. 20: Filling and draining points for the gear oil*

[1] Oil filling screw

[3] Oil drain screw

[2] Lubrication points for the gearbox (left and right)

**Checking the oil filling level**

- ▶ Open the oil filling screw [1].

*The oil level is OK is the screw dips into the oil in the sump.*

**10.6 Lubrication plan**

Lubrication points	Lubricant	Description
Universal drive shaft	Grease	See operator's manual of the manufacturer.
Metering slide Attachment lever	Grease, oil	Keep the product in good condition and lubricate it regularly.
Agitator shaft roller bearing left/right	Grease	Grease them before and after every spreading season.
Upper and lower link balls	Grease	Grease regularly.
Drive chain	Grease, oil	Grease them before and after every spreading season.
Lubrication points on the gearbox	Grease	Grease them before and after every spreading season.
Bearing for the drive shaft (within the chain guard box)	Grease	Grease them before and after every spreading season.

# 11 Faults and possible causes

## ⚠ DANGER!

**Repairs that are omitted or performed inadequately create a risk of injury or accidents.**

Delayed or incorrect repairs by unqualified personnel create incalculable risks leading to consequences such as injury to personnel as well as damage to the machine and the environment.

- ▶ Any faults that occur must be repaired immediately.
- ▶ Repairs may be carried out only by qualified personnel.

Fault	Possible cause/remedial action
Uneven spreading pattern	<ul style="list-style-type: none"> <li>• Discharge opening partly blocked.</li> <li>• Agitator fingers partly worn or damaged.</li> </ul>
Metering slide not opening.	<ul style="list-style-type: none"> <li>• The metering slide is sluggish.               <ul style="list-style-type: none"> <li>○ Check the metering slide and the lever for smooth movement and resolve problems as necessary.</li> </ul> </li> <li>• Push-pull cable defective               <ul style="list-style-type: none"> <li>○ Check it.</li> </ul> </li> <li>• Power supply to actuator interrupted.</li> </ul>
Agitator not working.	<ul style="list-style-type: none"> <li>• Check for wear.</li> <li>• Chain snapped               <ul style="list-style-type: none"> <li>○ Change the chain.</li> </ul> </li> <li>• Check the oil supply to the hydraulic motor</li> </ul>
Metering openings clogged by: Lumps of spreading material, damp spreading material, other contamination (leaves, straw, pieces of sacking)	<ul style="list-style-type: none"> <li>• Resolve the clogging. To do this:               <ol style="list-style-type: none"> <li>1. Switch off the tractor, remove the ignition key.</li> <li>2. Open metering slides.</li> <li>3. Place collecting vessel underneath.</li> <li>4. Clean the outlet by pushing a wooden stick or screwdriver through the metering opening from below.</li> <li>5. Remove foreign bodies from the hopper.</li> <li>6. Close the metering slide.</li> </ol> </li> </ul>

## 12 Optional equipment is available

### 12.1 UKS spreader for use in winter

#### 12.1.1 Electrical remote control EF 25

The electrical remote control allows you to control the metering slide from the tractor.

For the electrical remote, a 12V connection (2-pin socket) is required at the tractor.

#### 12.1.2 Mechanical remote control MFB 6/MFB 7

The mechanical remote control allows you to control the metering slide from the tractor.

#### 12.1.3 Extensions

The capacity of the universal hopper spreader can be increased by fitting a hopper extension.

The extensions are bolted to the standard hopper.



An overview of the extensions and extension combinations can be found in *Chapter 4.4 - Technical data for the extensions - Page 25*.

#### 12.1.4 Hopper tarpaulins

The hopper tarpaulins protect the spreading material from wet and moisture.

You can also fit the hopper tarpaulins to the hopper extensions.

Tarpaulins	Application
AP 18	Basic unit and extension UKS 80
AP 15	Basic unit and extension UKS 100
AP 17	Basic unit and extension UKS 120

#### 12.1.5 Lighting and warning signs (UKS 80/100/120)

The machine can be fitted with lighting.

Lighting	Application
BLW 7	<ul style="list-style-type: none"> <li>• Rear lighting</li> <li>• With warning sign</li> </ul>



Attachments are subject to the lighting regulations specified in the traffic regulations. Observe the traffic regulations of your country!

### 12.1.6 Lower link connection Cat. I, long

The long version of the lower link connections is used if it is necessary to maintain a large clearance between the tractor and attached spreader. It is bolted on to the standard shorter lower link connection.

### 12.1.7 Lower link connection Cat. I N

For attachment to tractors with Cat. I N.

### 12.1.8 Frame triangle Cat. I

The frame triangle is available for quick and easy coupling of the spreader to the tractor.



The frame triangle can be used only for universal hopper spreaders with hydraulic drive.

### 12.1.9 Hydraulic flow control valve (special design, UKS 100/120)

The hydraulic flow control valve is installed when the power of the hydraulic system on the tractor cannot be regulated to deliver a flow less than 25l/min.

## 12.2 UKS GB fertilizer spreader

### 12.2.1 Electrical remote control EF 25

The electrical remote control allows you to control the metering slide from the tractor.

For the electrical remote, a 12V connection (2-pin socket) is required at the tractor.

### 12.2.2 Mechanical remote control MFB 6/MFB 7

The mechanical remote control allows you to control the metering slide from the tractor.

### 12.2.3 Extensions

The capacity of the universal hopper spreader can be increased by fitting a hopper extension.

The extensions are bolted to the standard hopper.



An overview of the extensions and extension combinations can be found in *Chapter 4.4 - Technical data for the extensions - Page 25*.

### 12.2.4 Support stand feet

Set of 4 stand support feet (450 mm).

### 12.2.5 Windshield

Windshield	Application
WS 190	UKS 190
WS 230	UKS 230
WS 300	UKS 300

### 12.2.6 Hopper tarpaulins

The hopper tarpaulins protect the spreading material from wet and moisture.

You can also fit the hopper tarpaulins to the hopper extensions.

Tarpaulins	Application
AP 16	Basic unit and extension UKS 150
AP 20	Basic unit and extension UKS 190
AP 21	Basic unit and extension UKS 230
Ap 23	Basic unit and extension UKS 300

### 12.2.7 Lighting without warning signs

The machine can be fitted with lighting.

Lighting	Application
BLO 9	Rear lighting
BLO 10	Front lighting



Attachments are subject to the lighting regulations specified in the traffic regulations. Observe the traffic regulations of your country!

### **12.2.8 Row spreading system**

This spreading system is suitable for depositing dry, granulated fertilizer in rows next to sprouting plants.

### **12.2.9 Spreader mechanism**

The spreader mechanism is used for distribution of micro-granulates and seeds over a wide area.

### **12.2.10 Set of parts for category I (UKS 150, UKS 190)**

The set of parts for category I attachment is available for tractors whose coupling point corresponds to Cat. I.

### **12.2.11 Set of parts for category II**

The set of parts for category II attachment is available for tractors whose coupling point corresponds to Cat. II.

### **12.2.12 Frame triangle Cat. II**

The frame triangle is available for quick and easy coupling of the spreader to the tractor.

## 13 Axle load calculation

### 13.1 Calculation of the axle loading

**! WARNING!**

**Overload**

Mounted units on the front or rear three-point linkage must not cause the approved total weight to be exceeded.

- ▶ Before using the machine, ensure that these conditions are met.
- ▶ Implement the following calculations or weigh the tractor machine combination.

Determination of the overall weight, the axle loadings, the weight-bearing capacity of the tires and the necessary minimum ballasting.

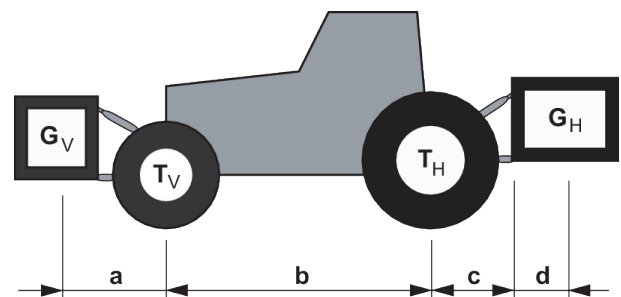

Fig. 21: Loads and weights

For the calculation, you require for following data:

Symbol [unit]	Meaning	Means of determination (see footnote to the table)
$T_L$ [kg]	Tare weight of the tractor	5
$T_V$ [kg]	Tare front axle load of the tractor	5
$T_H$ [kg]	Tare rear axle load of the tractor	5
$G_V$ [kg]	Total weight of the front-mounted equipment/front ballast	6
$G_H$ [kg]	Total weight of the rear-mounted equipment/rear ballast	6

<sup>5)</sup> See operator's manual for the tractor

<sup>6)</sup> See the price list and/or operator's manual for the unit

Symbol [unit]	Meaning	Means of determination (see footnote to the table)
a [m]	Distance between the center of gravity of the front-mounted equipment/front ballast and the center of the front axle	<sup>6</sup> - <sup>7</sup>
b [m]	Wheelbase of the tractor	<sup>8</sup> - <sup>7</sup>
c [m]	Distance between the center of gravity of the rear axle and the center of the lower link ball	<sup>8</sup> - <sup>7</sup>
d [m]	Distance between the center of the lower link ball and the center of gravity of the rear-mounted equipment/rear ballast	<sup>6</sup>

#### Rear-mounted equipment or front-rear combinations

Calculation of the front minimum ballasting  $G_V$  min

$$G_{V\min} = \frac{(G_H \times (c + d) - T_V \times b + 0,2 \times T_L \times b)}{a + b}$$

Enter the calculated minimum ballasting into the table.

#### Front-mounted equipment

Calculation of the rear minimum ballasting  $G_H$  min

$$G_{H\min} = \frac{(G_V \times a - T_H \times b + 0,45 \times T_L \times b)}{b + c + d}$$

Enter the calculated minimum ballasting into the table.

**If the front-mounted equipment ( $G_V$ ) is lighter in weight than the front minimum ballasting ( $G_{V\min}$ ), the weight of the front-mounted equipment must be increased to at least the front minimum ballasting weight requirement.**

Calculation of the actual front axle loading  $T_V$  tat

$$T_{V\text{tat}} = \frac{(G_V \times a - b + T_V \times b - G_H \times (c + d))}{b}$$

Enter the calculated actual front axle loading and the permissible front axle loading shown in the operator's manual of the tractor into the table.

<sup>6)</sup> See the price list and/or operator's manual for the unit

<sup>7)</sup> Dimensions

<sup>8)</sup> See operator's manual for the tractor

**If the rear-mounted equipment ( $G_H$ ) is lighter in weight than the rear minimum ballasting ( $G_{H\min}$ ), the weight of the rear-mounted equipment must be increased to at least the rear minimum ballasting weight requirement.**

Calculated actual overall weight  $G_{tat}$

$$G_{tat} = (G_V + T_L + G_H)$$

Enter the calculated actual front axle loading and the permissible front axle loading shown in the operator's manual of the tractor into the table.

Calculation of actual rear axle loading  $T_{Htat}$

$$T_{Htat} = (G_{tat} - G_{Vtat})$$

Enter the calculated actual front axle loading and the permissible front axle loading shown in the operator's manual of the tractor into the table.

Weight-bearing capacity of the tires

Enter the double value (if double tires are fitted) of the permissible weight-bearing capacity of the tires (see for instance the documentation supplied by the manufacturer of the tires) into the table.

## 13.2 Table of axles loadings

	Actual value Calculated value	Permissible value as listed in the operator's manual	Twice the permissible weight-bearing capacity of the tires (double tires)
Front/rear minimum ballasting	kg <input type="text"/>	-----	-----
Total weight	kg <input type="text"/>	≤ kg <input type="text"/>	-----
Front axle load	kg <input type="text"/>	≤ kg <input type="text"/>	≤ kg <input type="text"/>
Rear axle load	kg <input type="text"/>	≤ kg <input type="text"/>	≤ kg <input type="text"/>

### **NOTICE!**

**The minimum ballasting must be applied to the tractor, either in the form of mounted equipment or in form of ballast weight!**

- ▶ The calculated values must be less than or equal to the permissible values.

## 14 Disposal

### 14.1 Safety

#### **NOTICE!**

##### **Environmental pollution due to unsuitable disposal of hydraulic and transmission oil**

The hydraulic and transmission oils are not entirely biodegradable. Therefore, oil must be prevented from entering the environment in an uncontrolled manner.

- ▶ Collect/dam escaped oil with sand, soil, or other absorptive material.
- ▶ Collect hydraulic and transmission oil in a suitable container provided for the purpose, and dispose of it in accordance with the local statutory requirements.
- ▶ Draining and penetration of oil into the sewerage system is to be prevented.
- ▶ Prevent the penetration of oil into the water drain by setting up sand or earth barriers, or by using other appropriate barrier methods.

#### **NOTICE!**

##### **Environmental pollution caused by inappropriate disposal of packaging materials**

Packaging material contains chemical compounds, which must be dealt with appropriately.

- ▶ Packaging material is to be disposed of at an authorized waste management company.
- ▶ Observe the national regulations.
- ▶ Packaging material may not be burned nor disposed of with the domestic waste processing.

#### **NOTICE!**

##### **Environmental pollution caused by inappropriate disposal of components**

The inappropriate disposal of materials is a threat to the environment.

- ▶ Only authorized companies may be commissioned with disposal.

### 14.2 Disposal of the machine

The following points apply without restriction. Stipulate suitable precautionary measures based on the national legislation and implement them.

- ▶ All components, auxiliary and operating materials from the machine must be removed by specialist staff.
  - ▷ In so doing, these parts are to be sorted into specific categories.
- ▶ All waste products are then to be disposed of in accordance with local regulations and directives for recycling or special refuse categories by authorized companies.

## 15 Guarantee and warranty

RAUCH devices are manufactured using modern production methods and with the greatest of professional care, and are subjected to numerous inspections.

This is why RAUCH is offering a 12 month warranty if the following conditions are met:

- The warranty starts on the date of purchase.
- The warranty covers material or manufacturing defects. We are liable for third-party products (hydraulics, electronics) only to the extent of the relevant manufacturer. During the warranty period, manufacturing and material defects will be rectified free of charge with the replacement or repair of the affected parts. Other rights extending beyond the above, such as claims for conversion, reduction, or replacement for reasons of damage not suffered by the supplied product are explicitly excluded. Warranty services are provided by authorized workshops, by RAUCH factory representatives or the factory itself.
- Consequences of natural wear, dirt, corrosion, and all defects caused by improper use as well as external influences shall be excluded from the warranty. Any unauthorized repairs or changes to the original condition will void the warranty. The warranty is voided if any spare parts other than genuine RAUCH spare parts were used. Therefore, the directions in the operating manual must be observed. Please contact our company representatives of the parent company if you have any questions or doubts. Warranty claims must be submitted to the company within 30 days at the latest after the damage has occurred. The date of purchase and the machine number must be indicated. If repairs under the warranty are required, they must be carried out by the authorized workshop only after consultation with RAUCH or the company's appointed representatives. The warranty period will not be extended by warranty work. Transport damage is not a factory defect and is therefore not covered by the manufacturer's warranty manufacturer.
- Claims for damage other than to the RAUCH devices will not be accepted. This also means that no liability will be accepted for damage resulting from spreading errors. Unauthorized modifications of the RAUCH devices may result in consequential damage, for which the manufacturer will not accept any liability. The manufacturer's exclusion from liability will not apply in the case of willful intent or gross negligence by the owner or a senior employee, and in cases where – according to the product liability law – there is liability for personal injury or material damage to privately used objects in the event of defects in the supplied product. The exclusion from liability will also not apply if characteristics are missing that are explicitly guaranteed, if the purpose of their guarantee was to protect the purchaser against damage not suffered by the supplied product itself.

**RAUCH Streutabellen**  
**RAUCH Fertilizer Chart**  
**Tableaux d'épandage RAUCH**  
**Tabele wysiewu RAUCH**  
**RAUCH Strooitabellen**  
**RAUCH Tabella di spargimento**  
**RAUCH Spredetabellen**  
**RAUCH Levitystaulukot**  
**RAUCH Spridningstabellen**  
**RAUCH Tablas de abonado**



<https://streutabellen.rauch.de/>



**RAUCH Landmaschinenfabrik GmbH**

Victoria Boulevard E 200  
77836 Rheinmünster · Germany



info@rauch.de · www.rauch.de

Phone +49 (0) 7229/8580-0