



Operator's manual



**Please read carefully
before using the
machine!**

Keep for future use

This operator's and assembly manual is an integral part of the machine. Suppliers of new and second-hand machines are required to document in writing that the operator's and assembly manual was delivered with the machine and handed over to the customer.

AERO GT 60.1

5903494-C-en-0526

Original instructions

Foreword

Dear customer,

By purchasing the boom-type mineral fertilizer spreader, you have shown confidence in our product. Thank you very much! We want to justify this confidence. You have purchased a powerful and reliable machine.

However, in case unexpected problems arise, our customer service department is always there for you.



Please read this operator's manual carefully before commissioning the machine and follow the advice given.

This operator's manual gives detailed instructions on the operation of the machine, as well as valuable information on assembly, maintenance, and care.

This manual may also describe equipment that is not included in your machine.

Please note that damage caused by incorrect operation or improper use cannot be covered by warranty claims.



Please enter your model type and serial number, together with the year of manufacture of your machine here.
These data are provided on the machine nameplate or on the frame.
Please state this information when ordering spare parts or optional equipment, and in case of complaints.

Type:

Serial number:

Year of manufacture:

Technical improvements

We continuously strive to improve our products. For this reason, we reserve the right to make any improvements and changes to our machine that we consider necessary without notice. We do not accept any obligation to make such improvements or changes on machines that have already been sold.

We will be pleased to answer any other questions that you might have.

Yours sincerely

RAUCH Landmaschinenfabrik GmbH

Table of contents

1	Intended use	7
2	User instructions	8
2.1	About this operator's manual	8
2.2	Structure of the operator's manual	8
2.3	Notes on text descriptions	9
2.3.1	Instructions and procedures	9
2.3.2	Lists	9
2.3.3	References	9
3	Safety	10
3.1	General information	10
3.2	Meaning of warnings	10
3.3	General information on the safety of the machine	11
3.4	Instructions for the operator	11
3.4.1	Qualifications of personnel	11
3.4.2	Instruction	12
3.4.3	Accident prevention	12
3.5	Information on operational safety	12
3.5.1	Parking the machine	12
3.5.2	Filling the machine	13
3.5.3	Checks before commissioning the machine	13
3.5.4	Hazard zone	13
3.5.5	Running operation	14
3.5.6	Wheels and brakes	15
3.6	Using fertilizer	15
3.7	Hydraulics system	15
3.8	Maintenance and service	16
3.8.1	Qualifications of maintenance personnel	16
3.8.2	Wear parts	17
3.8.3	Maintenance and service tasks	17
3.9	Safety in traffic	17
3.9.1	Checks before driving	17
3.9.2	Road travel with the machine	18
3.10	Safety equipment, warnings and instructions	19
3.10.1	Position of safety equipment as well as warning and instruction stickers	19
3.10.2	Function of safety equipment	22
3.11	Warning and instruction stickers	22
3.11.1	Warning stickers	23
3.11.2	Instruction stickers	25
3.12	Name plate and machine marking	27
3.13	Lighting system, front, side, and rear reflectors	29
4	Machine data	30
4.1	Manufacturer	30
4.2	Description of the machine	30

4.2.1	Assembly overview	31
4.2.2	Blower	33
4.2.3	Metering unit and air duct	34
4.2.4	Boom	36
4.3	Technical specifications	36
4.3.1	Technical data for the basic equipment	36
4.3.2	Center of gravity	37
4.3.3	Wheels and tires	38
4.4	Special equipment	41
4.4.1	Metering shaft, delicate seeds	41
4.4.2	Herbicide metering shaft	42
4.4.3	DistanceControl	42
4.4.4	Multirate 6	42
4.4.5	FreeLane	43
4.4.6	D-GPS receiver	43
4.4.7	CCI/joystick bracket set	43
4.4.8	CCI A3 joystick	43
4.4.9	Part set cleaning	43
5	Transport without tractor	44
5.1	General safety instructions	44
5.2	Loading and unloading, parking	44
6	Commissioning	45
6.1	Accepting the machine	45
6.2	Type approval	45
6.3	Tractor requirements	45
6.4	Checking the height of the pin or ball coupling	46
6.5	Adjusting the trailer unit	46
6.6	Mounting the universal drive shaft on the machine	47
6.6.1	Dismounting the universal drive shaft	49
6.7	Installing the machine at the tractor	50
6.7.1	Preconditions	50
6.7.2	Mounting	52
6.8	Braking	55
6.9	Establishing other connections	56
6.10	Hydraulics system	56
6.11	Filling the machine	58
6.12	Checking the filling level	59
6.13	Camera for rear view monitoring	61
6.14	Switching on the machine control unit	63
7	Calibration test	64
7.1	Disconnecting the metering unit	65
7.2	Implementing the calibration test	67
7.3	Assembling the metering unit	69
8	Spreading operation	71
8.1	General information	71

8.2	Instructions regarding the spreading operation.....	71
8.3	Preparing the machine for driving.....	73
8.3.1	Disengaging the parking brake.....	73
8.3.2	Switching on the hydraulic system.....	73
8.4	Folding out the boom.....	74
8.5	Manual adjustment of the boom.....	75
8.6	Fertilizer spreading.....	76
8.6.1	Spreading operation.....	77
8.6.2	Spreading with section control.....	78
8.7	Folding in the boom.....	79
8.8	Discharging residual material.....	80
8.9	Parking and unhitching the machine.....	83
9	Faults and possible causes.....	87
10	Maintenance and service.....	92
10.1	Safety.....	92
10.2	Cleaning the machine.....	95
10.3	Wear parts and screw connections.....	96
10.3.1	Checking wear parts.....	96
10.3.2	Checking the bolted connections.....	96
10.4	Check metering unit and application.....	97
10.5	Replacing and removing the metering shaft.....	98
10.6	Checking and adjusting extended boom.....	99
10.7	Adjusting the holding force of the boom segments.....	102
10.8	Checking and adjusting the folded in boom.....	103
10.9	Electrics, electronic system.....	105
10.10	Hydraulics system.....	108
10.10.1	Checking the hydraulic hoses.....	109
10.10.2	Replacing hydraulic hoses.....	110
10.10.3	Nitrogen tank.....	111
10.10.4	Hydraulic cylinders for adjustment functions.....	112
10.10.5	Checking the hydraulic system of the Vario drive.....	113
10.10.6	Oil change and oil filter replacement.....	115
10.10.7	Checking other components.....	117
10.11	Chassis and brakes.....	119
10.11.1	Checking the condition and function of the braking system.....	119
10.11.2	Checking the free travel of the slack adjuster.....	119
10.11.3	Draining the air tank.....	121
10.11.4	Checking the brake pad.....	121
10.11.5	Checking the condition of the axle suspension.....	121
10.11.6	Checking the function of the axle suspension.....	122
10.12	Wheels and tires.....	123
10.12.1	Checking the tires.....	123
10.12.2	Checking the condition of the wheels.....	123
10.12.3	Checking the bearing clearance of the wheel hub.....	124
10.12.4	Changing wheels.....	124
10.13	Recovery of the machine.....	125

10.14 Lubrication	126
10.14.1 Drive shaft lubrication.....	126
10.14.2 Lubricating the pendulum frame.....	126
10.14.3 Lubricating the boom.....	128
10.14.4 Lubricating the parallelogram	129
10.14.5 Lubrication of links, bushes	131
10.14.6 Lubricating other components	131
11 Winterization and preservation.....	132
11.1 Safety	132
11.2 Washing the machine	132
11.3 Preserving the machine.....	133
12 Disposal.....	135
12.1 Safety	135
12.2 Disposal of the machine.....	135
13 Appendix.....	136
13.1 Tire table	137
13.2 Torque value	138
14 Guarantee and warranty	142

1 Intended use

The boom-type mineral fertilizer spreader AERO GT 60.1 may only be used in accordance with the stipulations of the present operator's manual.

The boom-type mineral fertilizer spreaders AERO GT 60.1 are constructed in accordance with their intended use.

They may only be used for the application of dry, granular and crystalline fertilizers, seeds and slug pellets.

The machine is intended to be coupled to a tractor and to be used by one person.

In the following chapters, the boom-type mineral fertilizer spreader is referred to as the "machine".

Any use beyond these specifications is considered as contrary to the intended use. The manufacturer shall not assume any liability for any damages resulting from this. The risk is solely carried by the operator.

The intended use also comprises the compliance with the operating, maintenance, and repair conditions prescribed by the manufacturer. Only genuine spare parts from RAUCH may be used as replacements.

The machine may only be used, maintained and repaired by people who are familiar with the characteristics of the machine and who are aware of the risks.

The instructions regarding the operation, service, and safe handling of the machine as described in this operator's manual and declared by the manufacturer in the form of warning signs and symbols on the machine must be strictly followed during operation. The relevant accident prevention regulations and other generally recognized safety-related, occupational health and road traffic regulations must be observed when using the machine.

Unauthorized modifications to the machine are not permitted. Such modifications exclude any liability of the manufacturer for any resulting damages.

■ **Foreseeable misuse**

The manufacturer provides warning notes and signs on the mineral fertilizer spreader relating to foreseeable misuse. These warnings and warning symbols must always be observed. This way, application of the machine against the intentions of the operator's manual is prevented.

2 User instructions

2.1 About this operator's manual

This operator's manual is an **integral part** of the machine.

The operator's manual contains important instructions for **safe, proper**, and economic **use** and **maintenance** of the machine. Compliance with its stipulations helps to **avoid risks**, reduce repair costs and downtime, and to increase the reliability and service life of the machine controlled with it.

The complete documentation, comprising this operator's manual and any other documents provided, must be kept in an easily accessible location close to where the machine is used (e.g., in the tractor).

If the machine is sold, the operator's manual must also be passed to the new owner.

The operator's manual is intended for the operator of the machine and anyone involved in operating and maintaining it. It must be read, understood, and applied by every person who is entrusted with the following work on the machine:

- Operation,
- Maintenance and cleaning,
- Troubleshooting.

In particular, the following is to be observed:

- The chapter on safety,
- The warnings in the text of the individual chapters.

The operator's manual does not replace your **own responsibility** as operator and operational staff of the machine control unit.

2.2 Structure of the operator's manual

The operator's manual is divided into six key areas in terms of content

- User instructions
- Safety instructions
- Machine data
- Instructions on operating the machine
 - Transport
 - Commissioning
 - Spreading operation
- Instructions for finding and correcting faults
- Maintenance and service instructions

2.3 Notes on text descriptions

2.3.1 Instructions and procedures

Steps that must be performed by operating staff are displayed as follows

- ▶ Instructions step 1
- ▶ Instructions step 2

2.3.2 Lists

Lists without a specific sequence are shown as lists with bullet points:

- Property A
- Property B

2.3.3 References

References to other sections in the document are shown with paragraph number, header text and/or page number:

- **Example:** Please also note 3 *Safety*

References to other documents are shown as information or instructions without the exact chapter or page number:

- **Example:** Follow the instructions in the operator's manual of the universal drive shaft manufacturer.

3 Safety

3.1 General information

The chapter **Safety** contains basic warning notes as well as working and traffic safety instructions for the usage of the installed machine.

The adherence to the instructions in this chapter is a prerequisite for the safe handling and trouble-free operation of the machine.

There are additional warnings in the other chapters of this operator's manual, which must also be observed. The warning instructions are given before the text for the relevant actions.

Warning notes on the supplier components can be found in the respective supplier documentation. These warning instructions must also be observed.

3.2 Meaning of warnings

The warnings in the operator's manual are classified according to the severity of the risk and the probability of its occurrence.

The warning symbols draw attention to the residual risks to which users of the machine are exposed. The warnings used are structured as follows:

Symbol + **signal word**

Explanation

Level of danger of warnings

The level of danger is indicated in the signal word. The levels of danger are classified as follows:

DANGER!

Type and source of danger

This warning warns of a danger posing an immediate threat to the health and life of people.

Ignoring these warnings will result in severe injury or death.

- ▶ Always observe the measures described to prevent this danger.

WARNING!

Type and source of danger

This warning warns of a potentially dangerous situation for personal health.

Ignoring these warnings leads to severe injury.

- ▶ Always observe the measures described to prevent this danger.

⚠ CAUTION!**Type and source of danger**

This warning warns of a potentially dangerous situation for personal health.

Ignoring these warnings leads to injury.

- ▶ Always observe the measures described to prevent this danger.

NOTICE!**Type and source of danger**

This warning warns of material and environmental damage.

Ignoring these warnings will result in damage to the machine and to the environment.

- ▶ Always observe the measures described to prevent this danger.



This is an instruction:

General instructions contain tips for the operation and information that is particularly useful, but no warnings about hazards.

3.3 General information on the safety of the machine

The machine is state-of-the-art and is compliant with the applicable technical regulations. However, during its use and maintenance, risks to the health and life of the user or third parties or damage to the machine and other objects can still occur.

For this reason, the machine may only be operated:

- In a flawless and roadworthy condition,
- Taking into account safety and risks.

This requires you to have read and understood the contents of this operator's manual. You must be aware of the relevant accident prevention regulations as well as the generally acknowledged safety, occupational health and traffic regulations and be able to apply them.

3.4 Instructions for the operator

The owner is responsible for the intended use of the machine.

3.4.1 Qualifications of personnel

Before starting any work on or with the machine, all persons who are involved in operation, maintenance or service must have read and understood this operator's manual.

- The machine may only be operated by instructed personnel authorized by the owner.
- Persons who are apprentices, in training or under instruction may only work on the machine under the supervision of an experienced person.
- Maintenance and service may only be carried out by qualified maintenance personnel.

3.4.2 Instruction

Distribution partners, works representatives or employees of the manufacturer will instruct the operator regarding the operation and maintenance of the machine.

The owner must ensure that newly recruited operating and maintenance personnel are instructed to the same extent and with the same care with regard to the operation and repair of the machine in compliance with this operator's manual.

3.4.3 Accident prevention

Safety and accident prevention regulations are legally specified in every country. The owner of the machine is responsible for observing the regulations applicable in the country of operation.

The following instructions must also be observed:

- Never let the machine run without supervision.
- Do not ride on the machine while it is working or being transported (**no passengers**).
- **Do not use** machine parts as steps.
- Always wear tight fitting clothes. Do not wear work clothes with belts, loose threads or other items that could get caught.
- Follow the manufacturer's warnings when handling chemicals. You may have to wear personal protective equipment (PPE).

3.5 Information on operational safety

Only use the machine in safe operating condition. Avoid hazardous situations.

3.5.1 Parking the machine

Only park the machine with an empty hopper and with the boom folded in on level, solid ground.

Prior to decoupling, check that the machine is secured against tilting and rolling.

- Is the parking brake engaged?
- Is the support stand folded down?
- Are the wheels secured with wheel chocks?

For further information, refer to chapter *8.9 Parking and unhitching the machine*

3.5.2 Filling the machine

- Couple the machine to the tractor prior to filling it.
Only fill the machine when the tractor is at a standstill. Remove the ignition key in order to prevent the engine from being started.
- Avoid one-sided loads on the axle due to uneven loading of the machine.
- Use suitable auxiliary equipment for filling the machine (e.g. front-end loader, screw conveyor).
- Please observe the admissible overall weight.
- Check the filling level.
- Only fill the machine with the protective grid closed. This way, faults during spreading caused by lumps in the spreading material or other foreign bodies are prevented.

3.5.3 Checks before commissioning the machine

Check the operating safety of the machine before the first and every subsequent commissioning.

- Is all safety equipment at the machine installed and functioning?
- Are all fasteners and load-bearing connections tightly installed and in good condition?
- Are all locking mechanisms securely engaged?
- Are there **no** persons in the danger zone of the machine?
- Is the universal drive shaft cover in good condition?

3.5.4 Hazard zone

Ejected spreader material may cause serious injury (e.g. to the eyes).

When persons are present between the tractor and the machine, there is a great hazard by the tractor rolling away of machine movements. When persons are present between the tractor and the machine which may have fatal consequences.

The following figure displays the hazard zones of the machine.

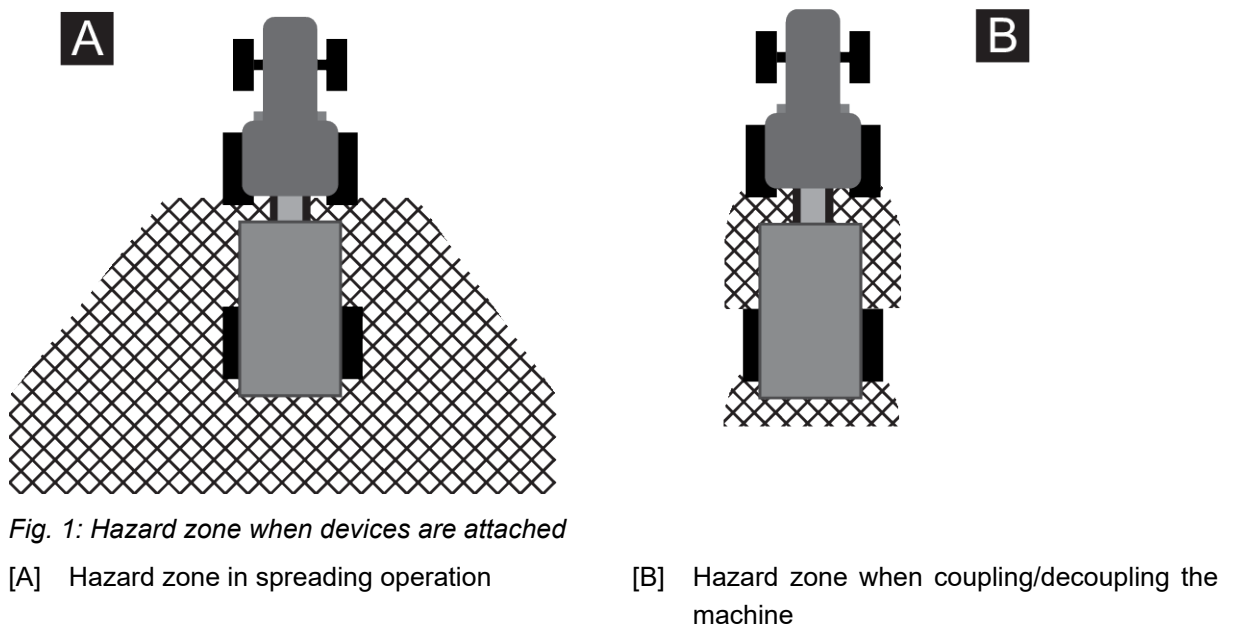

- During spreading operation or when folding the boom in/out, ensure that no persons are present in the spreading range [A] of the machine.
- Immediately stop the machine and the tractor if persons are present in the hazard zone of the machine.
- When coupling/decoupling the machine at the tractor or swiveling the swivel frame, make sure that no one is present in the hazard zones [B].

3.5.5 Running operation

- In the event of malfunctions, the machine must be shut down immediately and secured against reactivation. Have the fault repaired immediately by qualified technicians.
- Never climb on the machine.
- Only operate the machine with the protective grid in the hopper closed. During operation, the protective grid must **neither be opened nor removed**.
- Only operate the machine when the protective covers are installed.
- Rotating machine components can cause serious injury. Make sure that body parts or clothing never come close to rotating components.
- Do not deposit any parts (such as screws, nuts) in the hopper.
- Leaked fertilizer may cause serious injuries (e.g., to the eyes). For this reason, ensure that nobody is present in the spreading range of the machine.
- If the wind speed becomes too high, spreading has to be stopped as the specified spreading range cannot be guaranteed under such conditions.
- Before operating the boom, make sure that there is sufficient space available, that there are no persons in the hazard zone, and that there are no other obstacles in the way.
- If the terrain is uneven, the boom can come into contact with the ground or with obstacles. Avoid dangerous situations such as touching live overhead lines.
- Only swing the boom in and out on level surfaces.
- Only swing the boom in and when the tractor is stationary.
- Do not swing the boom in and out in close proximity to overhead lines. Make sure to maintain a sufficiently safe distance.
- Ensure that the swivel frame is in the operating position and locked on the left and right before starting the swinging process.
- Do not climb on the machine or the tractor when it is situated beneath high-voltage electrical power lines.
- Operations such as folding in, folding out, leveling the boom, etc., can change the dimensions of the machine. Check the area to make sure that the machine can be operated safely.

■ **Measures in the event of contact with overhead lines**

- Do not leave the vehicle if it is standing underneath a hazardous voltage (discharge voltage pattern).
- In case of contact with power lines, remain in the vehicle if possible.
- Keep all persons away from the machine (at least 10 m) and contact emergency services to ask them to switch off power.
- Drive away from the power line if the machine is operational.
If you have to leave the cabin, park the machine, turn off the engine, and jump away from the machine as far as possible. Do not touch the ground and the machine at the same time as this may result in electric shock.
- Maintain a safe distance from the machine as the ground near the machine can be live.
- Do not return to the machine until the operator of the power line has confirmed that it is safe to do so.

3.5.6 Wheels and brakes

Due to the high overall weight and the terrain, the chassis of the towed machine is subject to extreme loads. To ensure operational safety, the following points are to be considered:

- All wheels and tires must comply with the technical requirements specified by the manufacturer.
- Wheels must not be bent or have inadmissible bumps.
- Check the wheels at their sides on the inside and outside. In case of damage (bumps, scratches), replace them immediately.
- Prior to every use, check the tire pressure and the function of the brakes.
- Have the brake pads replaced in time. All brake pads must comply with the technical requirements specified by the manufacturer.
- To prevent contamination of the wheel bearings, they must always be covered by dust covers.
- If a Certificate of Conformity for EU type approval (as per EU directive 167/2013) was issued for the machine, the wheels specified in the Certificate of Conformity are permissible.
- Always observe the specification of the approved wheels (load bearing capacity, tire pressure).
- Check the brake pads when changing the tires and when using tires other than those approved by the manufacturer. See *4.3.3 Wheels and tires*
- **Do not use the tractor joystick for braking** This way, trailers with pneumatic brakes cannot be stopped.

3.6 Using fertilizer

Use of fertilizers, seeds or crop protection products

Improper selection or use of fertilizers, seeds or crop protection products may cause serious injury or environmental damage.

- When selecting the fertilizers, seeds or crop protection products, inform yourself of its effects on humans, the environment and the machine.
- Refer to the instructions and safety data sheets issued by the manufacturers.

3.7 Hydraulics system

The hydraulic system is under high pressure.

Fluid escaping under high pressure may cause serious injury and environmental damage. The following instructions must be observed to prevent danger:

- Always operate the machine below the permissible maximum operating pressure.
- **Release the pressure** from the hydraulic system **before** carrying out any maintenance. Switch off the engine of the tractor. Secure it against reactivation.
- When searching for leaks, always wear safety **glasses** and safety **gloves**.
- In case of injury in connection with hydraulic oil, consult **a physician immediately** as severe infections may occur.
- When connecting the hydraulic hoses to the tractor, ensure that the hydraulic system is **depressurized**, both on the tractor and the machine side.
- Attach the hydraulic hoses of the tractor and the spreader hydraulic systems only with the prescribed connections.
- Prevent any contamination of the hydraulic circuit. Always suspend the couplings in the brackets provided. Use the dust caps. Clean the connections before coupling them.
- Regularly check the hydraulic components and hydraulic hose lines for mechanical defects, e.g., cuts and abrasions, contusions, bends, tears, porosity, etc.
- Even when stored correctly and used within approved load limits, hoses and hose couplings are subject to a natural aging process. This limits their storage and service life.

The hydraulic hoses are designed for a maximum service life of 6 years, including storage for a maximum of 2 years.

The month and year of manufacture of the hydraulic hoses is stamped on the hose fitting.

- Have the hydraulic hoses replaced if they are damaged and after the specified service life has been reached.
- Replacement hydraulic hoses must meet the technical requirements of the equipment manufacturer. Make sure the replacement hydraulic hoses meet the maximum pressure specifications.

3.8 Maintenance and service

Maintenance and service involve additional hazards that do not occur during operation of the machine.

For this reason, take particular care when carrying out maintenance and service work. Work particularly thoroughly and cautiously.

3.8.1 Qualifications of maintenance personnel

- Only specialist workshops or approved brake repair service providers may perform adjustment or repair work on the brake system.
- Only qualified personnel may perform repair work on wheels and tires. They must use appropriate mounting tools for this.
- Welding and work on the electrical and hydraulic systems is to be carried out by qualified technicians only.

3.8.2 Wear parts

- The maintenance and service intervals described in the present operator's manual are to be strictly adhered to at all times.
- Also observe the maintenance and service intervals for the supplied components. See the supplier documentation for the relevant intervals.
- We recommend that you have the condition of the machine and particularly of attached components, safety-relevant plastic components, the hydraulic system, and metering elements checked by your specialist dealer after each season.
- Have the brake pads replaced in time. Only use the brake pads dedicated for the axles.
- Spare parts must at least comply with the technical standards specified by the manufacturer. Compliance with technical requirements is ensured using original spare parts.
- Self-locking nuts are designed to be used only once. Always use new self-locking nuts to fasten components.

3.8.3 Maintenance and service tasks

- **Always switch off the tractor engine** before any cleaning, maintenance, service, and troubleshooting. **Wait until all rotating parts of the machine have come to a standstill.**
- Make sure that **no** unauthorized person can start the machine. Remove the ignition key of the tractor.
- Disconnect the power supply between the tractor and the machine before performing any maintenance and service tasks or before working on the electrical system.
- Check that the tractor is correctly parked with the towed machine. Park the spreader with an empty hopper and the boom folded in on level, solid ground and secure it to prevent it from moving.
- Release the pressure from the hydraulic system before any maintenance and repair work.
- If work is to be carried out while the universal drive shaft is rotating, make sure that nobody is near the universal drive shaft.
- Never clear blockages in the spreader hopper by hand or with the foot: always use a suitable tool.
- Only open the protective grid in the hopper if the machine has been decommissioned.
- Before cleaning the machine with water, steam jet, or other cleaning agents, cover all components that must not get wet (e.g., bearings, electrical connections).
- Regularly check nuts and screws for tightness. Retighten loose connections.
- After driving the first 5 km, check the tightening torque of each individual wheel nut. See *10.12.4 Changing wheels*

3.9 Safety in traffic

When driving on public streets and roads, the tractor with the attached machine must comply with the road traffic regulations of the respective country. The owner and driver are responsible for compliance with these regulations.

3.9.1 Checks before driving

The check before departure is an important contribution to road safety. Before every trip, check compliance with the operating conditions, traffic safety, and the regulations of the country of operation.

- Is the admissible overall weight complied with? Observe the admissible towing load and static load of the trailer unit as well as the admissible axle load.
- Note the permitted brake load, the permitted tire load capacity load, and the permitted tire pressure.
- Is the machine coupled correctly?
- Can fertilizer be lost while traveling?
 - Observe the filling level of the fertilizer in the hopper.
 - The boom must be folded in.
 - Deactivate the spreading functions of the machine control unit.
- Are the boom parts fully folded in and the locking mechanisms secured?
- Check the tire pressures and the function of the machine brake system. Observe the admissible brake load and tire payload.
- Is the hopper cover closed and secured against accidental opening?
- Do the lighting and labeling on the machine comply with the national regulations for operation on public roads? Make sure that warning signs, rear reflectors, and auxiliary lights are correctly placed.
- Switch on the hydraulic system for the control block on the machine and activate the axle suspension "Automatic".

3.9.2 Road travel with the machine

Handling, steering, and braking performance of the tractor are affected by the towed machine. For example, an excessive support load of the machine will reduce the weight on the front axle of the tractor and affect the steering.

- Adapt your driving to the modified driving characteristics.
- When driving, always ensure that there is sufficient visibility. If vision is restricted (e.g., when reversing), another person is required to direct the driver.
- Observe the admissible maximum speed.
- Different load conditions and the specific weight of the fertilizer affect the center of gravity.
- Avoid sudden turns when driving uphill or downhill or across a slope. The change in the center of gravity may increase the danger of tipping. Special care is to be particularly applied when driving on uneven, soft ground (e.g., when entering fields, curbs).
- Passengers are prohibited on the machine during transport and operation.
- Only drive with the axle suspension activated.
- If necessary, attach a front weight at the tractor. For further information, please refer to the operator's manual of the tractor.

3.10 Safety equipment, warnings and instructions

3.10.1 Position of safety equipment as well as warning and instruction stickers

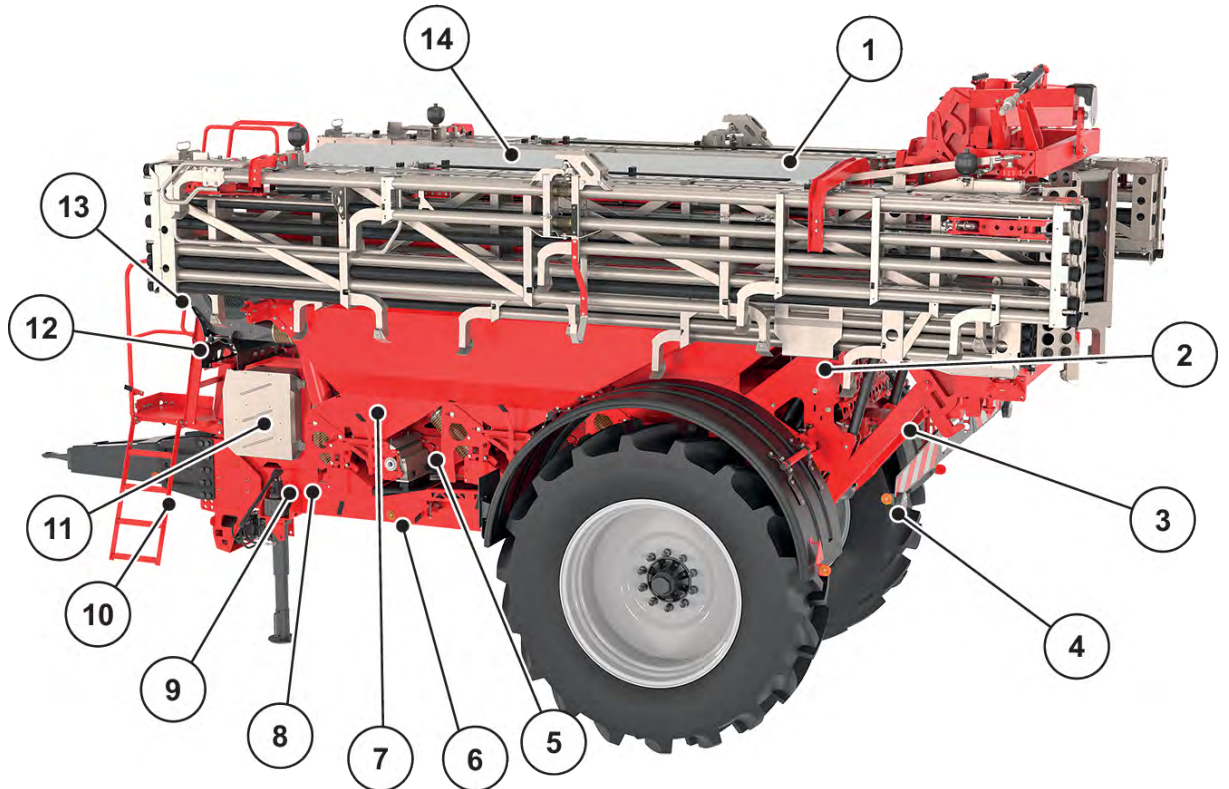

Fig. 2: Safety equipment, warning and instruction stickers, left side

- | | |
|---|---|
| [1] Hopper cover | [9] Warning: Read the operator's manual |
| [2] Instructions: Checking wheel nuts | [10] Warning: Transport of passengers prohibited |
| [3] Warning: Danger of crushing | [11] Warning: Splash water prohibited (on the inside of the door) |
| [4] Red reflectors | [12] White position light with warning sign |
| [5] Safety equipment, metering shaft | [13] Warning: Risk of falling |
| [6] Yellow side reflectors | [14] Protective grid in the hopper |
| [7] Instructions: Section control breakdown | |
| [8] Warning: Remove the ignition key | |

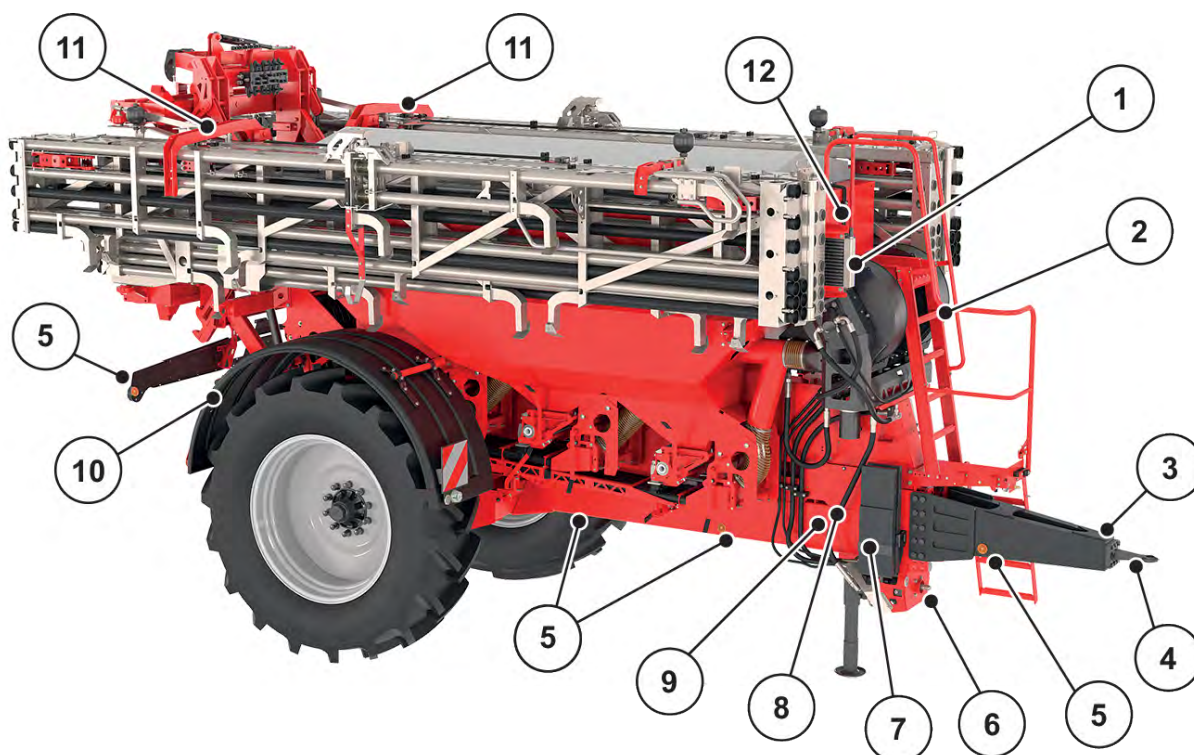

Fig. 3: Safety equipment, warning and instruction stickers, right side

- | | |
|----------------------------------|---|
| [1] Safety equipment, oil cooler | [8] Serial number AERO GT 60.1 |
| [2] Safety equipment, blower | Homologation sign AERO GT 60.1 |
| [3] Towing bar nameplate | [9] Technical data, brake force regulator |
| [4] Trailer unit nameplate | [10] Mud guard |
| [5] Yellow side reflectors | [11] Safety equipment, boom |
| [6] Instructions: PTO speed | [12] Warning: high-voltage electrical power lines |
| [7] Warning: wheel chocks | |

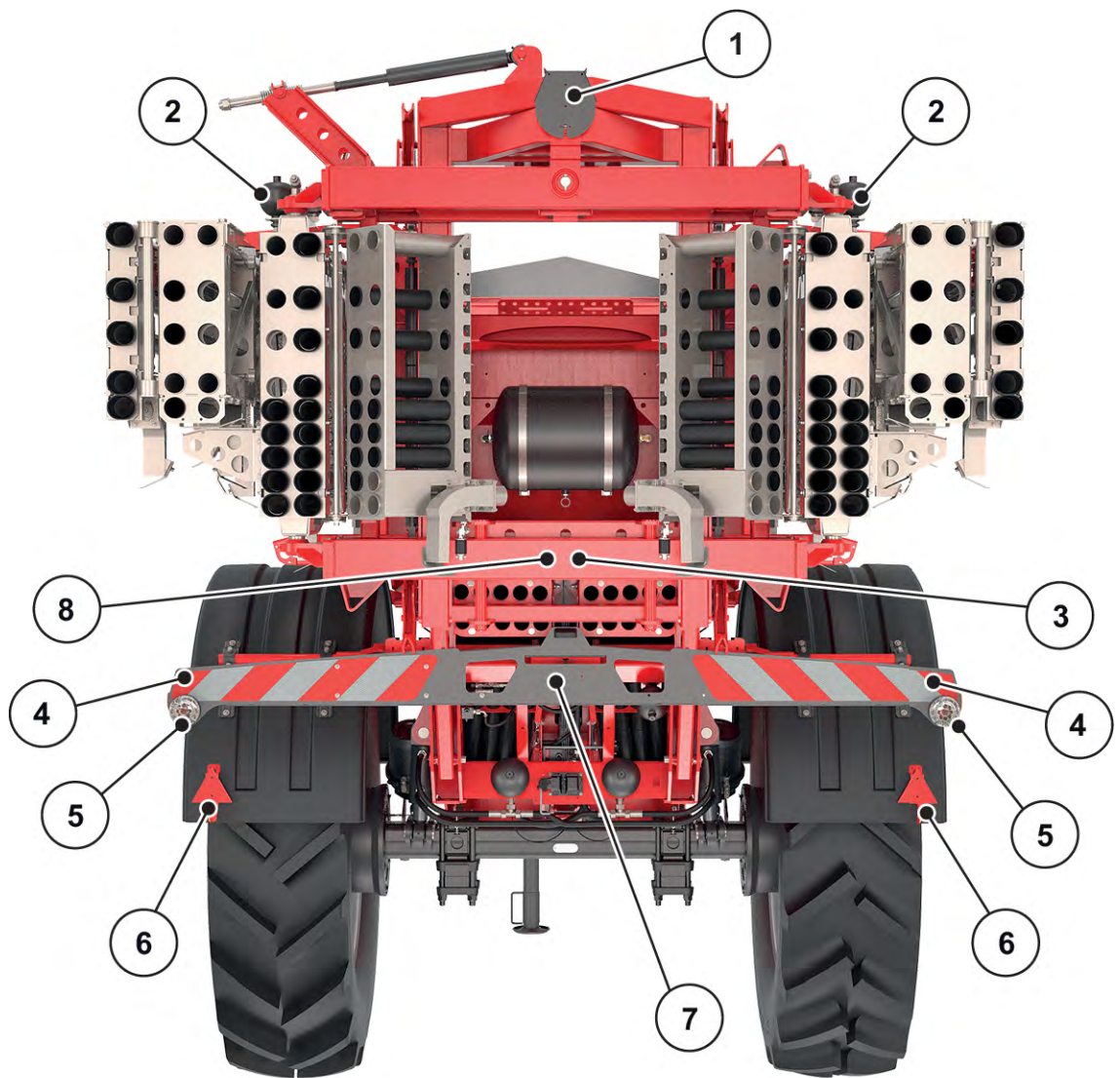

Fig. 4: Safety equipment, warning and instruction stickers, rear

- | | |
|------------------------------|--|
| [1] Admissible maximum speed | [5] Tail light, brake light, indicator |
| [2] Warning: Nitrogen | [6] Red rear reflectors |
| [3] Warning: Sinking parts | [7] Rear view camera |
| [4] Warning sign | [8] Warning: Ejection of material |

[1] Universal drive shaft cover

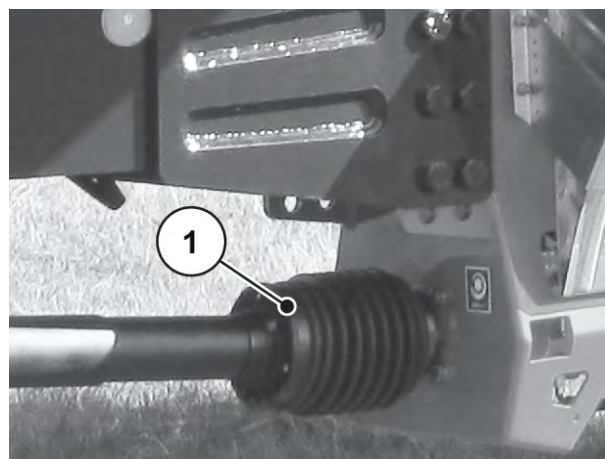

Fig. 5: Universal drive shaft cover

3.10.2 Function of safety equipment

The safety equipment is designed to protect your health and life.

- Before working with the machine, ensure that the safety equipment is functioning properly and is not damaged.
- Operate the machine only when the safety equipment is fully functional.

Designation	Function
Protective grid in the hopper	Prevents access to the metering shafts from the hopper. Prevents faults during spreading caused by lumps in the spreading material, large stones or other large objects (screening effect).
Cover of blower drive	Prevents body parts from being pulled into the blower mounting.
Intake grille of blower	Prevents larger objects from being pulled in and reaching into the intake area of the blower.
Cover, cam wheel on the metering shaft	Prevents body parts from being pulled into the metering elements. Cover on each metering unit.
Protective cover for spur gear	Prevents body parts from being pulled into the drive elements of the metering units located on the side.
Rear view camera	Supports reversing and prevents accidents due to insufficient view from the tractor cabin
Universal drive shaft guard	Prevents body parts and clothing from being pulled into the rotating universal drive shaft.

3.11 Warning and instruction stickers

Various warning and instruction stickers are attached to the machine (for the position at the machine, please refer to 3.10.1 *Position of safety equipment as well as warning and instruction stickers*).

The warning and instruction stickers are components of the machine. They must not be removed or modified.

- ▶ Replace missing or illegible warning and instruction stickers immediately.

If new components are installed during repairs, the same warning and instruction stickers that were on the original parts must be placed on the new parts.



The correct warning and instruction stickers can be obtained from the spare parts service.

3.11.1 Warning stickers





Illustration	Description
	Read the operator's manual and warnings. Read and observe the operator's manual and warnings before commissioning the machine. The operator's manual explains in detail how to operate the spreader and contains valuable information on operation, care and maintenance.
	Remove the ignition key. Switch off the engine and remove the key before carrying out maintenance and repair work. Disconnect the power supply
	Crushing hazard Risk of crushing a hand. It is prohibited to reach into the hazard zone.
	Danger due to ejection of material Danger of injury to the whole body caused by ejected spreading material Before commissioning, instruct all people to leave the hazard zone (spreading range) of the machine.
	Danger due to moving parts Danger of cutting off body parts It is prohibited to reach into the hazard zone of rotating parts. Switch off the engine and remove the key before carrying out maintenance, repair and adjustment work.







Illustration	Description
	<p>Danger between the tractor and the machine</p> <p>There is a crushing hazard that may result in fatal injury for persons standing between the tractor and the machine when the tractor approaches or the hydraulic system is actuated.</p> <p>The tractor may brake too late or not at all because of carelessness or incorrect operation.</p> <p>Ensure that nobody is present in the hazard zone between the tractor and the machine.</p>
	<p>Passenger transport prohibited</p> <p>Risk of slipping and injury. Do not climb on the machine during spreading and transport.</p>
	<p>Risk of death due to live overhead lines</p> <p>Never park the machine under live overhead lines. Keep safety distance. Only switch the boom from the transport to the spreader position and vice versa and fold the boom in and out in locations without overhead lines.</p>
	<p>Danger from hydraulic system</p> <p>Hot fluid escaping under high pressure may cause serious injury. It may also penetrate the skin and cause infection.</p> <p>De-pressurize the hydraulic system before maintenance work.</p> <p>When checking for leakage, wear protective goggles and protective gloves at all times.</p> <p>In the event of injury caused by hydraulic oil, seek medical attention immediately!</p> <p>Observe the manufacturer documentation.</p>
	<p>Crushing hazard in the folding and swivel range of the boom.</p> <p>It is prohibited to stand in the folding and swivel range of the boom while it is operated by the hydraulic system.</p> <p>Switch off the engine and remove the key before carrying out maintenance, repair and adjustment work.</p>
	<p>Danger due to sinking parts</p> <p>Do not stand under unsecured loads.</p> <p>Before going under the machine or the boom, use support devices to prevent the boom from lowering inadvertently.</p> <p>When operating any moving parts of the boom, make sure that there are no people or objects in this area.</p>

Illustration	Description
	<p>Ban on splash water It is prohibited to splash water into the housing of the job computer and other electronic components.</p>

3.11.2 Instruction stickers



Illustration	Description
	<p>Rated speed of the PTO shaft The rated speed of the PTO shaft is 1000 rpm.</p>
	<p>Wheel nut check Reference to tightening torques as specified in the operator's manual. Refer to chapter 10.12 <i>Wheels and tires</i></p>

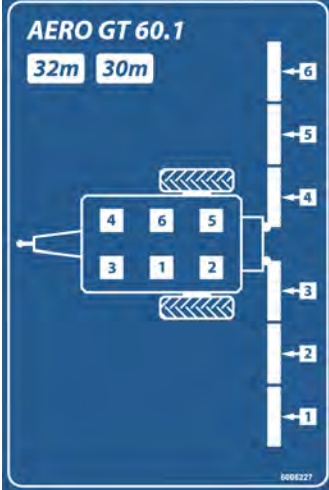
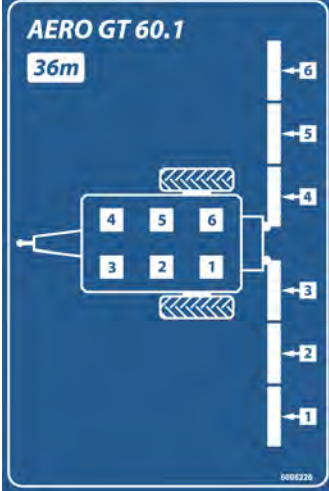





Illustration	Description
	<p>Lubrication point</p>
	<p>AERO GT 60.1, 30/32 m Distribution of the boom part widths and the metering shafts</p>
	<p>AERO GT 60.1, 36 m Distribution of the boom part widths and the metering shafts</p>
	<p>Nameplate: Brake system</p>

Illustration	Description
	Trailer unit nameplate
	Admissible maximum speed
	Distribution of pressure chamber/air duct levers, left side in direction of travel
	Distribution of pressure chamber/air duct levers, right side in direction of travel
	Application point for the lifting jack

3.12 Name plate and machine marking



When delivering your machine, ensure that all necessary signs are present.

Depending on the country of destination, additional signs can be attached to the machine.

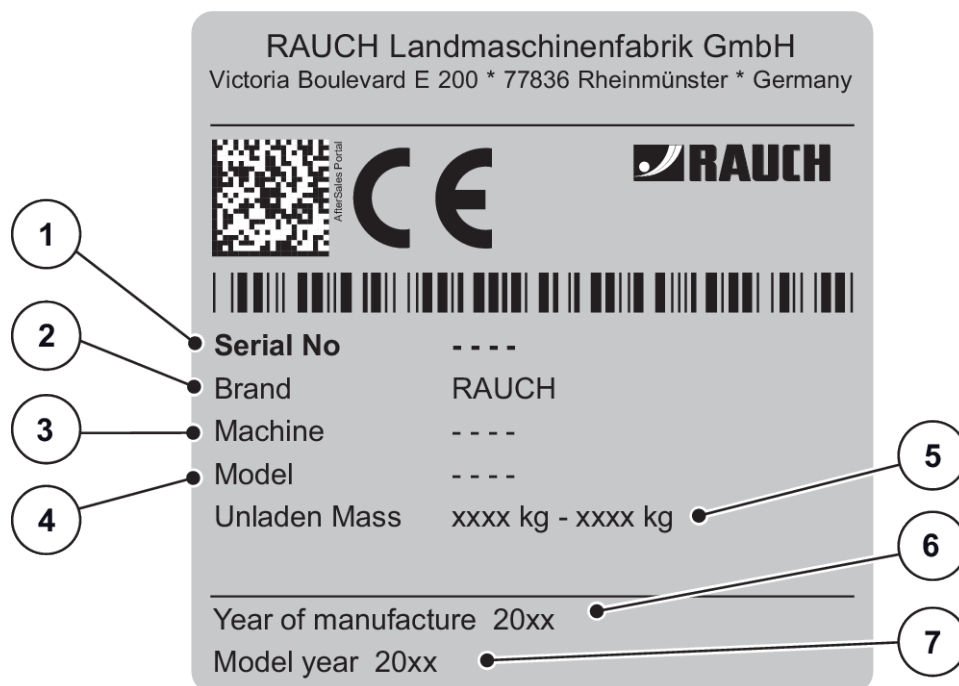

Fig. 6: Nameplate

- [1] Serial number
- [2] Manufacturer
- [3] Machine
- [4] Type

- [5] Empty weight
- [6] Year of construction
- [7] Model year

Brand		RAUCH Landmaschinenfabrik GmbH			
Cat.		---			
Approval No		---			
Serial No		RLxxxxxxxxxxxxxxxx			
Max. permissible masses	Total kg			
	Drawbar	A-0 kg		
	Axle 1	A-1 kg		
	Axle 2	A-2 kg		
	Axle 3	A-3 kg		
	Towable Config	B-1	T-1	T-2	T-3
	Brake-B x	B-2			
	Tong. -T	B-3			
		B-4			

Fig. 7: Homologation sign

- | | |
|-----------------------------|-------------------------------|
| [1] Manufacturer | [5] Admissible overall weight |
| [2] Category | [6] Admissible static load |
| [3] EU type approval number | [7] Admissible axle load |
| [4] Serial number | |

3.13 Lighting system, front, side, and rear reflectors

- ▶ Correctly attach the lighting equipment to the machine as specified.

The lighting equipment must always be in operating condition.

Lights must not be covered or obscured by dirt.

The machine is factory-equipped with a lighting system and front, rear, and side lighting (for attachment to the machine, please refer to 3.10.1 *Position of safety equipment as well as warning and instruction stickers*).

4 Machine data

4.1 Manufacturer

RAUCH Landmaschinenfabrik GmbH
Victoria Boulevard E 200
77836 Rheinmünster
Germany

Phone: +49 (0) 7229 8580-0

Fax: +49 (0) 7229 8580-200

Service Center, Technical Customer Service

RAUCH Landmaschinenfabrik GmbH
PO box 1162
Email: service@rauch.de
Fax: +49 (0) 7229 8580-203

4.2 Description of the machine

Use the machine in accordance with chapter 1 *Intended use*.

The machine consists of the following assemblies.

- Hopper with frame
- Drive elements (drive shaft and transmission)
- Metering elements (blower, metering shaft, air duct)
- Boom consisting of 2 boom sides with 3 segments each. The overall boom has 6 sections See *4.2.4 Boom*
- Pendulum frame
- 30 bends: 14 each per boom side and 2 on the pendulum frame
- Safety equipment - See *3.10.1 Position of safety equipment as well as warning and instruction stickers*



Some models are not available in all countries.

4.2.1 Assembly overview

■ Basic machine

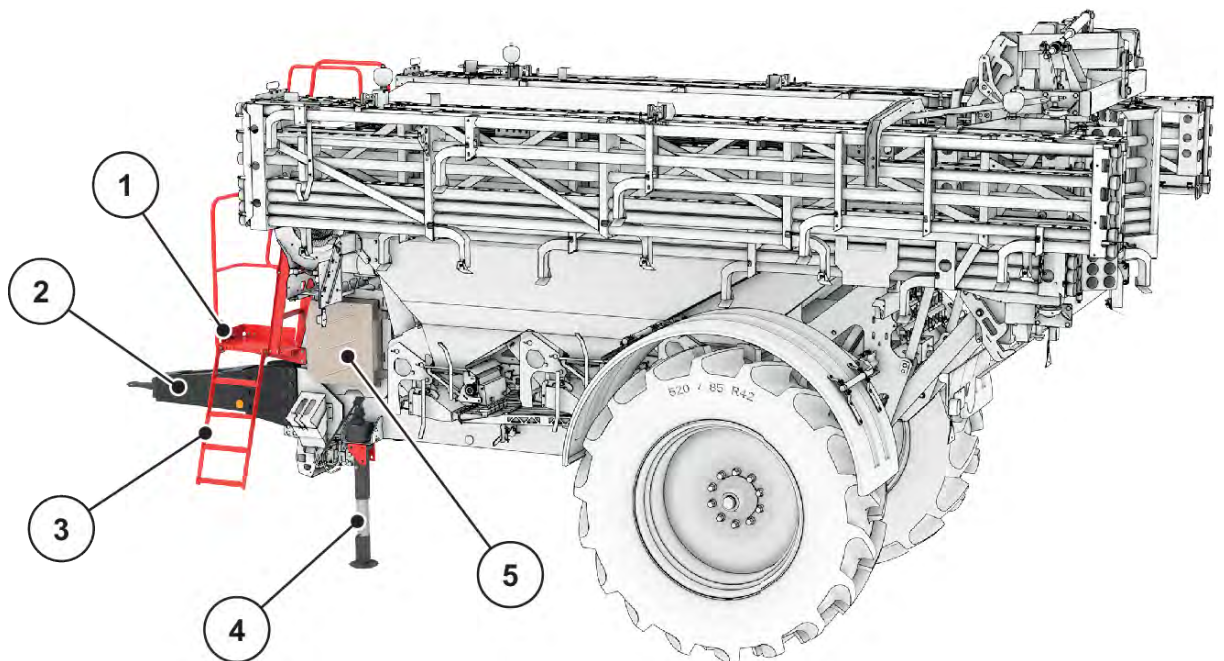

Fig. 8: Assembly overview: Left side view

- | | |
|-------------------------------------|---------------------|
| [1] Parking brake | [4] Support stand |
| [2] Towing bar and trailer coupling | [5] Control cabinet |
| [3] Folding steps | |

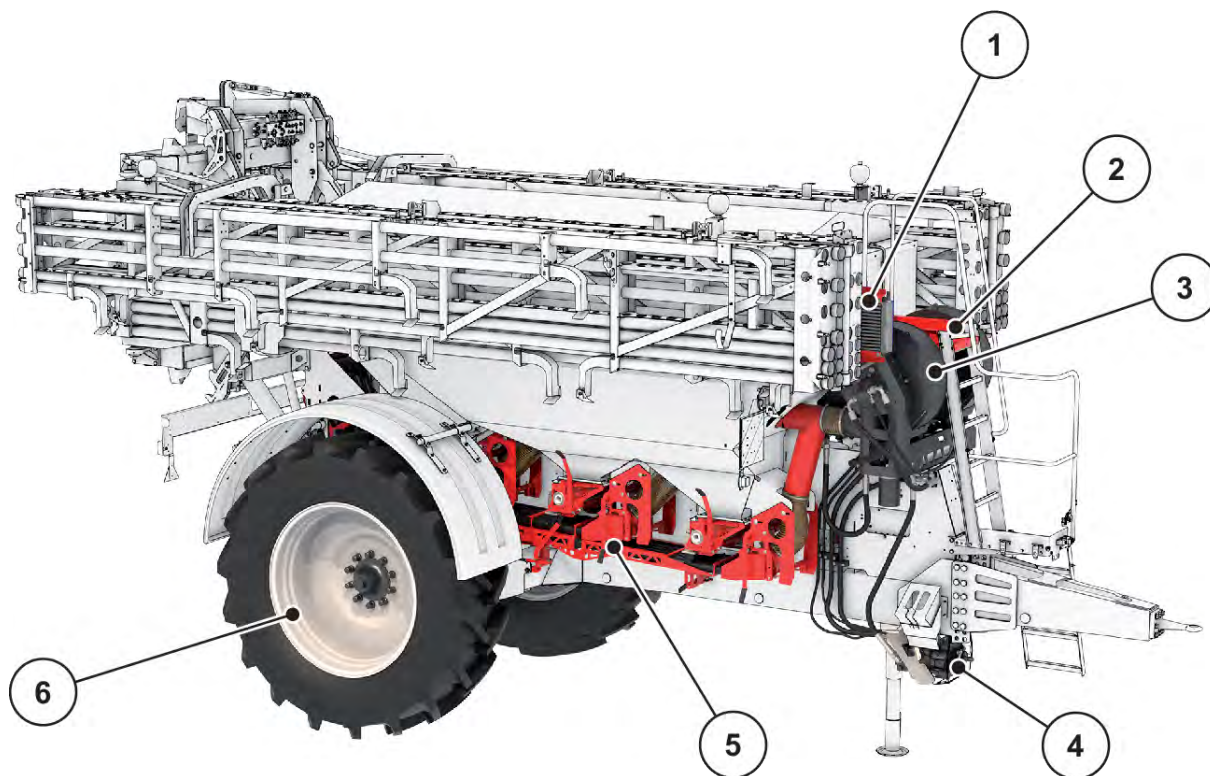

Fig. 9: Assembly overview: Front

- | | |
|----------------|------------------------|
| [1] Oil cooler | [4] Transmission unit |
| [2] Platform | [5] Metering unit (6x) |
| [3] Blower | [6] Wheel |



This assembly is available as standard or as an option depending on the machine and the market.

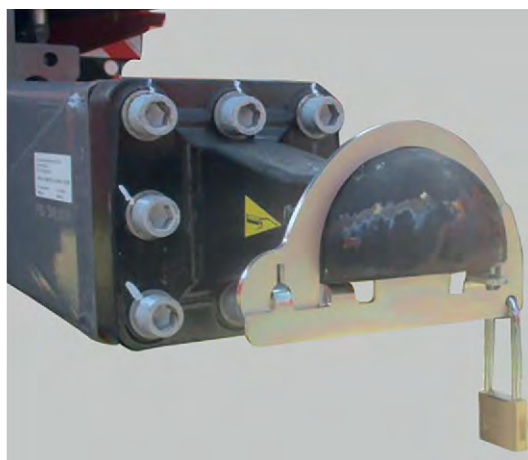

Fig. 10: Securing to prevent unauthorized use on trailer units

4.2.2 Blower

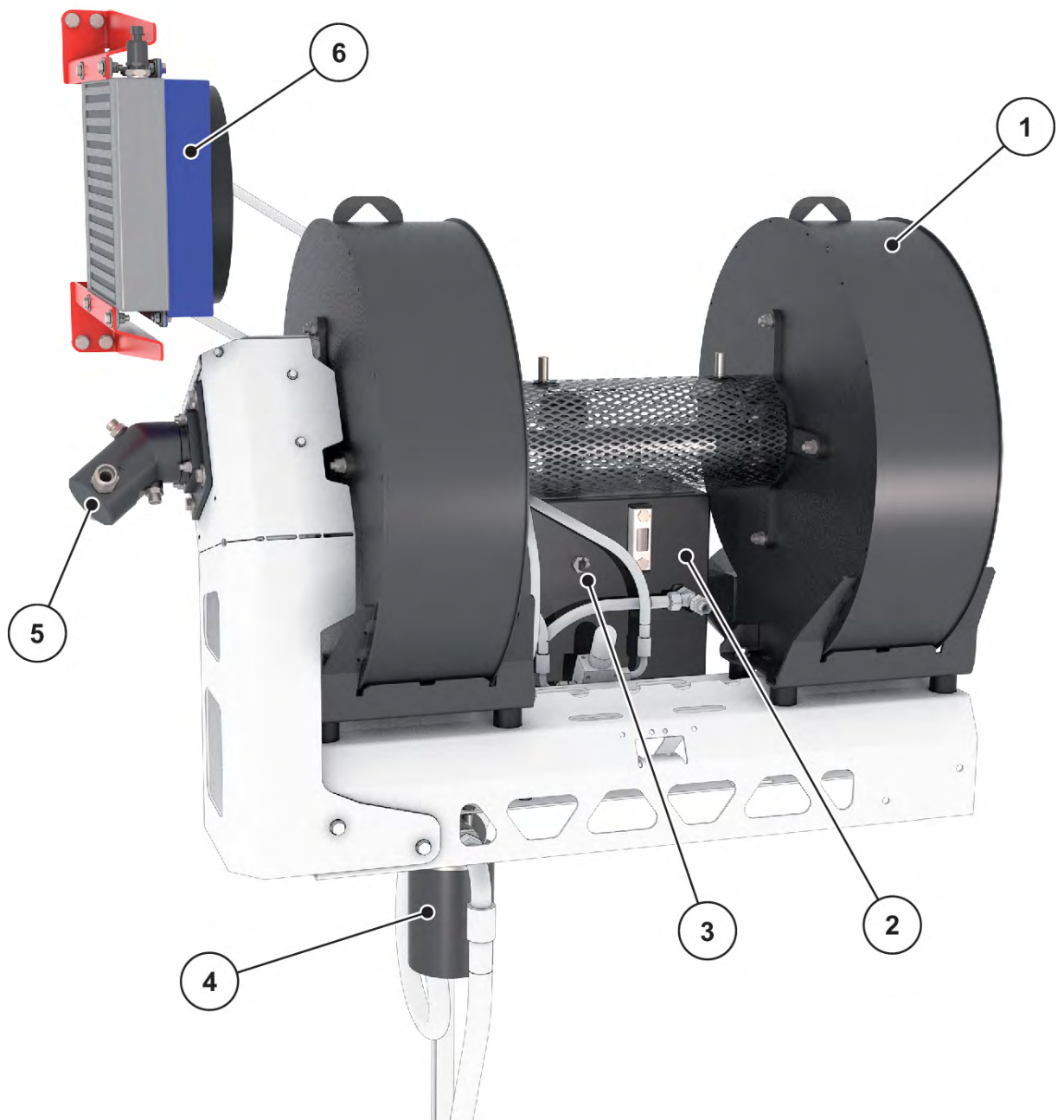

Fig. 11: Assemblies and functions of the machine, blower

- | | |
|---|------------------------|
| [1] Two blowers connected via a shaft | [4] Oil filter |
| [2] Oil tank with filling level indicator | [5] Blower drive motor |
| [3] Filling level sensor | [6] Oil cooler |

4.2.3 Metering unit and air duct

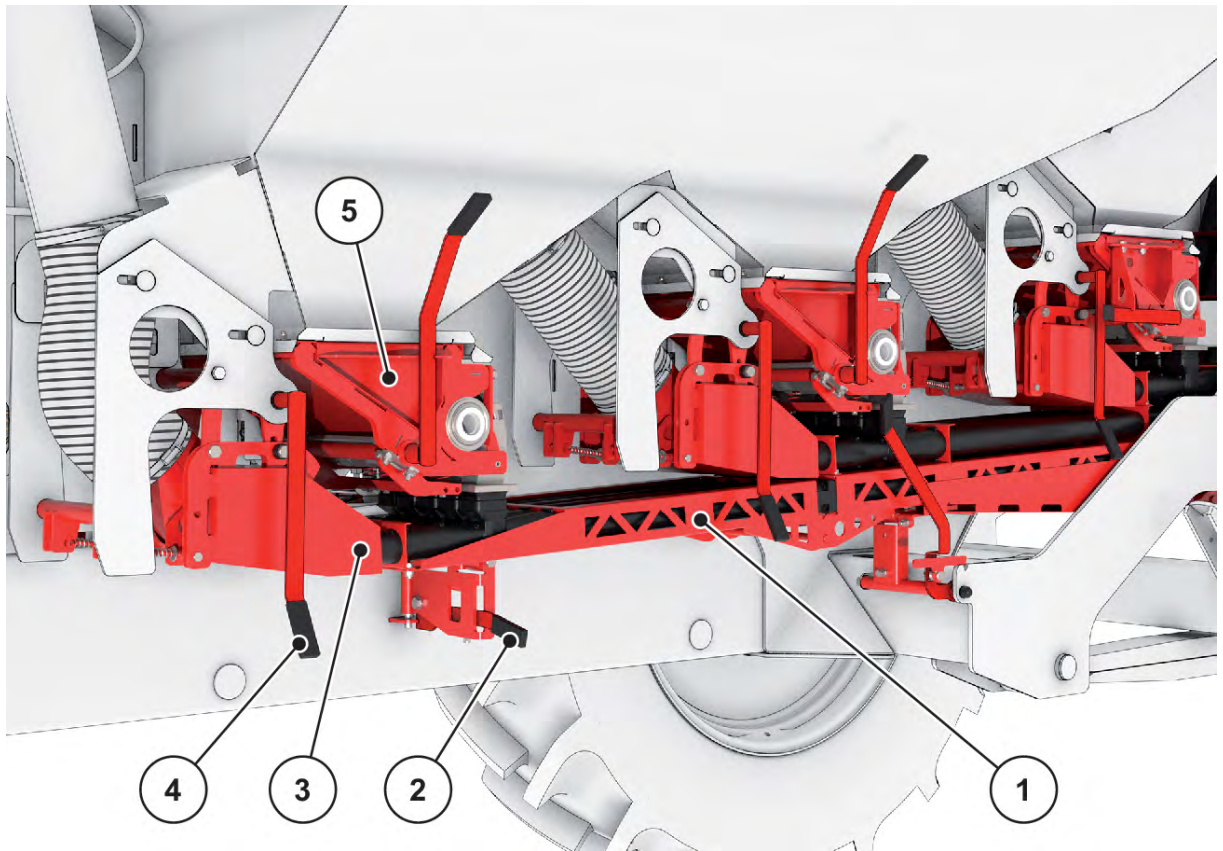

Fig. 12: Assemblies and function of the machine, detail of right side view

- [1] Air duct
- [2] Air duct locking mechanism (2 x)
- [3] Pressure chamber (3 x)
- [4] Lever for pulling back the pressure chamber (3 x)
- [5] Metering unit, see also *Fig. 13 Assemblies and functions of the machine, metering unit*

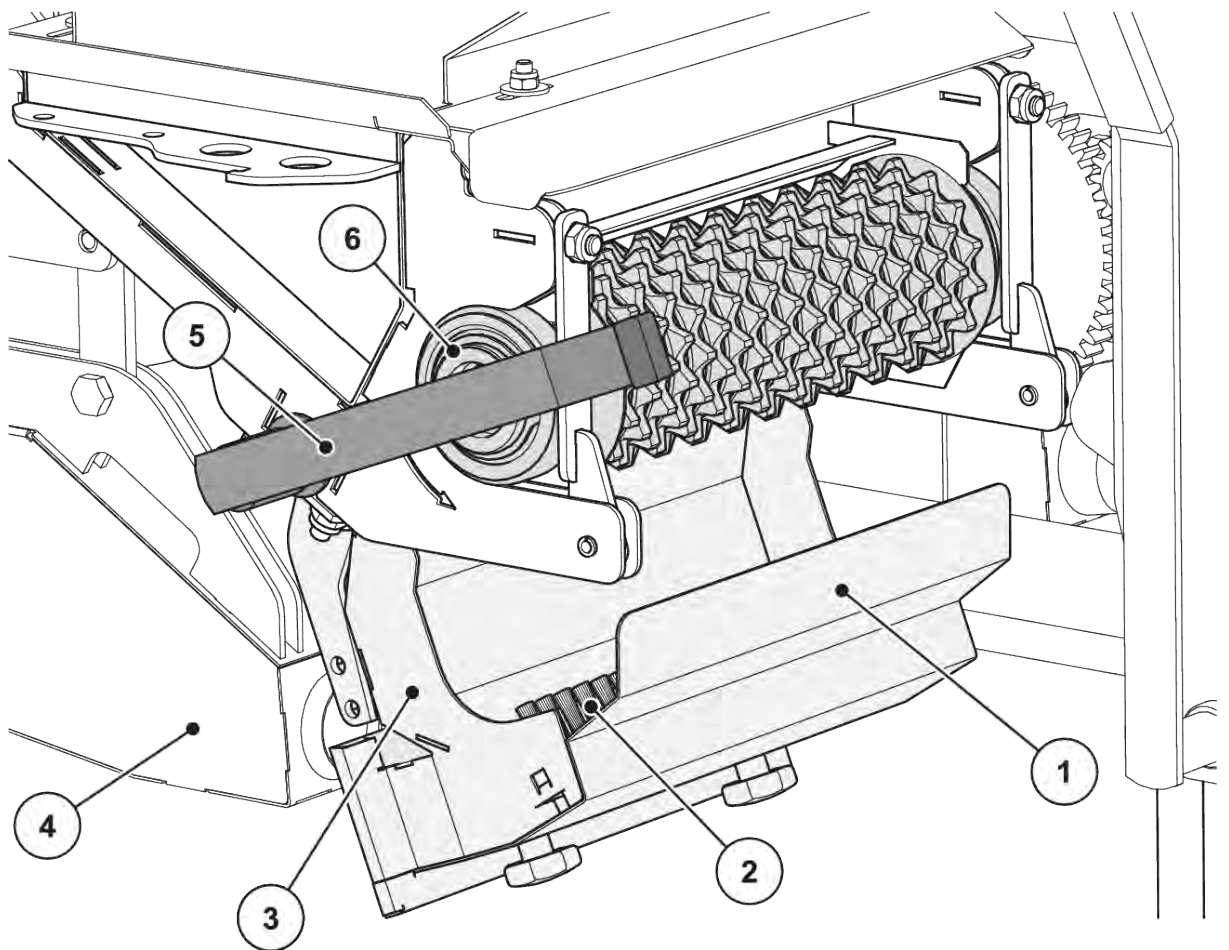

Fig. 13: Assemblies and functions of the machine, metering unit

- | | |
|---------------------------------------|--|
| [1] Cover of metering unit | [4] Pressure chamber |
| [2] Brush strip | [5] Lever for moving the metering tank |
| [3] Metering tank (here: folded open) | [6] Metering shaft |

The metering shaft [6] can be replaced, if necessary. Information on the procedure can be found in the installation manual.

4.2.4 Boom

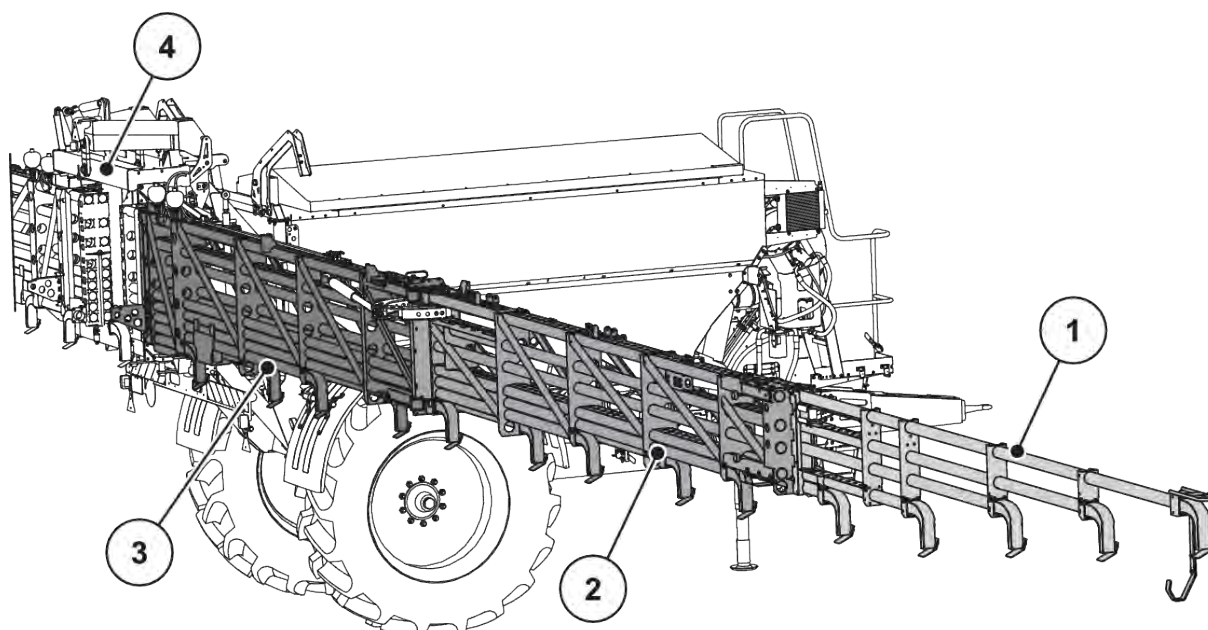

Fig. 14: Assemblies and function of the machine, boom

- | | |
|---|--------------------|
| [1] End section with collision protection | [3] Start section |
| [2] Central section | [4] Pendulum frame |

4.3 Technical specifications

4.3.1 Technical data for the basic equipment

Data	AERO GT 60.1		
	30 m	32 m	36 m
Length of trailer unit to end of vehicle	8300 mm		
Length of trailer unit to axle	5400 mm		
Total height ¹	3970 mm		
Overall width ²	2980 mm		
Filling opening	3806 x 1550 mm		
Filling level	3150 mm		
PTO speed	750-1000 RPM		
Hopper capacity	6300 l		

¹⁾ Depending on the tires of the machine

²⁾ Other widths depend on the country and the equipment (axle, wheels)

Data	AERO GT 60.1		
	30 m	32 m	36 m
Hydraulic supply	60 l, 180 bar		
Sound pressure level ³ (measured in the closed driver's cab of the tractor)	75 dB(A)		

■ Weights and loads



The empty weight (mass) of the machine varies depending on the working width, the equipment and extension combination.

The technical specifications of the Certificate of Conformity (CoC) apply if a CoC has been issued for this machine.

Data	AERO GT 60.1
Admissible axle load	10000 kg
Empty weight ⁴	7000 kg
Fertilizer payload ⁵	5000 kg
Admissible static load	2000 kg

4.3.2 Center of gravity



The position of the center of gravity depends on the coupling type as well as the filling level in the hopper.

³⁾ Since the sound pressure level of the machine can only be determined when the tractor is running, the actual measured value is greatly dependent on the tractor type being used.

⁴⁾ At 36 m in decoupled condition

⁵⁾ The exact payload depends on the machine's equipment.

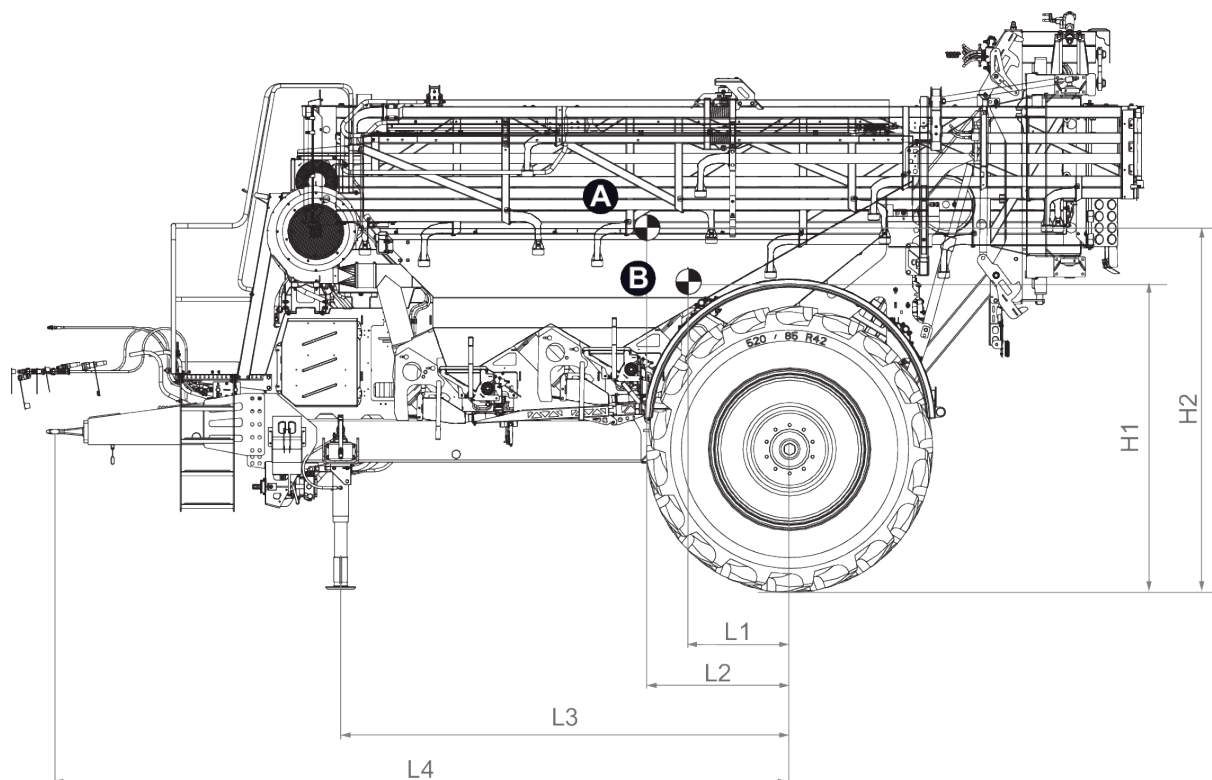

Fig. 15: Center of gravity

[A] Center of gravity with full hopper

[B] Center of gravity with empty hopper

Length	Bottom hitching (mm)
L1	470
L2	850
L3	3110
L4	5110
H1	2150
H2	2210

4.3.3 Wheels and tires



Some models are not available in all countries.

The load index indicates the load bearing capacity for tires.

The speed category indicates the maximum permissible road speed for tires.

The equipment on the machine determines the speed category and load bearing capacity required for the tires.

The load bearing capacity of a tire varies depending on the operating road speed and inflation pressure of the tire.

For machines with air brakes and a 10 t axle load:

- Speed category
 - A8 for 40 km/h
- Load index (Li)
 - min. 164 (for load bearing capacity 5000 kg per wheel)

Speed category	A5	A6	A7	A8
Maximum speed in km/h	25	30	35	40

Load Index	164	165	166	167	168	169	170	171	172	173
Tire load bearing capacity in kg	5000	5150	5300	5450	5600	5800	6000	6150	6300	6500



The air pressure can vary widely by manufacturer.

- Observe the air pressure depending on the tire manufacturer's load bearing capacity.



The required tire pressure depends on the tire manufacturer and the type.

- Observe the tire pressure recommended by the manufacturer.

Possible factory-equipped tires

Tire size	Track width in m	Rigid axle 2 m	Rigid axle 2.50 m	Rigid axle 3 m	Tire pressure in bar Load bearing capacity: 5000 kg at 40 km/h
480/80 R46	2.25	x	-	-	See tire manufacturer's data sheet
	2.50	-	x	-	
	3.00	-	-	o	
520/85 R42	2.25	x	-	-	
	2.50	-	o	-	
	3.00	-	-	o	
520/85 R46	2.25	x	-	-	
	2.50	-	o	-	
	3.00	-	-	o	
650/65 R42	2.25	x	-	-	
	2.50	-	o	-	
	3.00	-	-	o	
650/85 R38	2.25	x	-	-	
	2.50	-	o	-	
	3.00	-	-	o	
710/70 R42	2.25	x	-	-	
	2.50	-	o	-	
	3.00	-	-	o	
IF 580/85 R42	2.25	x	-	-	
	2.50	-	o	-	
	3.00	-	-	o	
VF 520/85 R42	2.25	x	-	-	
	2.50	-	o	-	
	3.00	-	-	o	
VF 520/85 R46	2.25	x	-	-	
	2.50	-	o	-	
	3.00	-	-	o	
VF 650/65 R42	2.25	x	-	-	
	2.50	-	o	-	
	3.00	-	-	o	

Table legend

- x: available for this machine variant
- o: Limited availability (depending on country)
- -: not available

Other wheels, track widths, and axle variants upon request

4.4 Special equipment



We recommend that the extra equipment should be fitted and mounted on the basic machine by the supplier or a specialist workshop.



Some models are not available in all countries.



The available special equipment depends on the country of use of the machine and is not listed fully here.

- If you require specific special equipment, ask your dealer or importer.

4.4.1 Metering shaft, delicate seeds

For AERO GT 60.1, 36 m



Fig. 16: Metering shaft, delicate seeds

For AERO GT 60.1, 30 m



Fig. 17: Metering shaft, delicate seeds

4.4.2 Herbicide metering shaft



For fertilizer spreading units that are also intended to apply plant protection products, the applicable national regulations on equipment inspection must be observed. Depending on the country, regular inspections by recognized inspection bodies may be required.

For AERO GT 60.1, 30 m



Fig. 18: Herbicide metering shaft

4.4.3 DistanceControl

Ultrasonic sensors are used to move the boom to the optimum height and the correct inclination for the existing plants.

The DistanceControl function is activated via the ISOBUS machine control unit.



Contact your dealer to activate the function.

4.4.4 Multirate 6

The hydraulically driven MultiRate metering units permit a separate application rate for each of the sections. This makes it possible to represent application cards with an even greater application accuracy.

4.4.5 FreeLane

The FreeLane system prevents fertilizer from being sprayed into the tractor tracks.

The following equipment is required for the FreeLane system:

- Special guiding devices
- Adapted cam wheel metering system

4.4.6 D-GPS receiver

Permits free reception of the EGNOS correction signal with an accuracy of $\pm 0,30$ m.

4.4.7 CCI/joystick bracket set

To equip a second tractor for use with the machine

4.4.8 CCI A3 joystick

Illustration	Designation
	<p>CCI A3 joystick (the key assignment can differ depending on the machine)</p>

4.4.9 Part set cleaning

Equipment consisting of a compressed air gun with additional compressed air tank

5 Transport without tractor

5.1 General safety instructions

NOTICE!

Property damages caused by incorrect transport

The eyelets in the hopper are **not** suitable for lifting the overall machine. They are only intended for transport of the hopper during production and assembly.

Non-compliance leads to damage at the machine.

- ▶ Make sure to observe the manufacturer's transport instructions.

Read the following instructions before transporting the machine:

- Without tractor, the machine may only be transported with an empty hopper.
- Only suitable, instructed and expressly authorized persons may execute the work.
- Suitable means of transportation and lifting equipment (e.g. crane, forklift truck, lifting tackle ...) are to be used.
- Establish the transportation route in good time and remove possible obstacles.
- Check that all safety and transportation devices are fully operational.
- Secure all danger areas appropriately, even if they only exist briefly.
- When lifting the machine, do so via the crane attachment eyes in the hopper (if present).
- The person responsible for transportation must ensure that the machine is transported appropriately.
- Unauthorized persons are to be kept away from the transport route. Cordon off the affected areas!
- Transport the machine cautiously and handle it with care.
- Ensure that allowances are made for the center of gravity. If necessary, adjust the cables to ensure that the machine is correctly aligned on the means of transport.
- Transport the machine to the set-up location as close to the ground as possible.

5.2 Loading and unloading, parking

- ▶ Determine the weight of the machine.
 - ▷ Check the details on the name plate.
 - ▷ Take the weight of mounted optional equipment into account.
- ▶ Carefully lift the machine with suitable lifting equipment.
- ▶ Carefully place the machine on the loading platform of the transportation vehicle or on solid ground.

6 Commissioning

6.1 Accepting the machine

When accepting the machine, check the delivery for completeness.

The standard equipment includes:

- 1 AERO GT 60.1 boom-type mineral fertilizer spreader
- 1 AERO GT 60.1 operator's manual
- Protective grid in hopper
- Level sensor in hopper
- 2 wheel chocks
- 1 wide-angle universal drive shaft (including operator's manual)
- 1 electronic machine control unit with AERO ISOBUS operator's manual

Also check any special equipment that was ordered.

Check for any transport damage or missing parts. Have any shipping damage acknowledged by the forwarding agent.

If in doubt, consult the dealer.

6.2 Type approval

Please observe the applicable road traffic regulations of the respective country or the location of use of the machine. If required, the importing body will register the machine at the respective registration office for traveling on public roads.

- For additional identification (warning signs, lighting) please contact your dealer or importer.

6.3 Tractor requirements

To ensure a safe and correct use of the machine, the tractor must meet the necessary mechanical, hydraulic, and electrical requirements.

- Tractor engine power: At least 180 HP
- Permissible static load at the pin or ball coupling: 2000 kg
- 1 single-acting control unit for the hydraulic block/axle
- 1 double-acting control unit for the hopper cover
- 1 free return
- Connections for the pneumatic brake system DIN ISO 1728 (control line and supply line)
- Universal drive shaft connection:
 - 1 3/8 inches, 6-part, 750 - 1000 rpm or
 - 1 3/4 inches, 20-part, 750 - 1000 rpm
- Oil supply: At least 60 l/min at $p = 180$ bar
- ISOBUS connection for job computer, as per ISO 11783
- 7-pin socket according to ISO 1727 for the lighting system

6.4 Checking the height of the pin or ball coupling

Depending on the equipment, the machine is hitched to the tractor's pin or ball coupling.

Before the machine is used for the first time, the height of the pin coupling or ball coupling must be adjusted correctly.

NOTICE!

Machine damage due to incorrect adjustment of the coupling

If the pin or ball coupling is adjusted incorrectly or not adjusted properly, the operational safety of the towing system (tractor/machine) is impaired.

- ▶ Properly adjust the height of the pin or ball coupling.
 - ▶ Follow the instructions in the operator's manual of the tractor.
- ▶ Adjust the towing bar so that the machine is horizontal after it is hitched to the tractor and there is enough space to install the universal drive shaft to the tractor.

6.5 Adjusting the trailer unit

If the height of the coupling point on the tractor cannot be adjusted to suit, install the attachment fitting on the machine one row of holes (approx. 45 mm) further up or down.

Requirement:

- The hopper is empty.
- The boom is folded in and locked.
- The machine is parked on level, solid ground.

Please observe the instructions in chapter 8.9 *Parking and unhitching the machine*.

⚠ WARNING!

Crushing hazard

The towing bar has a dead weight of approximately 80 kg. If it falls down, this can lead to crushing injuries.

- ▶ Secure the towing bar against falling down.
- ▶ Wear personal protective equipment during operation.

- ▶ Release the screw connections [1].
- ▶ Bring the towing bar into the new position at the top [3] or bottom [2] and secure it.
- ▶ Tighten the screw connections with a tightening torque of 775 Nm.

The requirement is:

- 20 hexagon head screws ISO 4014 M24x75 FK10.9
- 20 hexagon nuts ISO 4032 M24 FK10

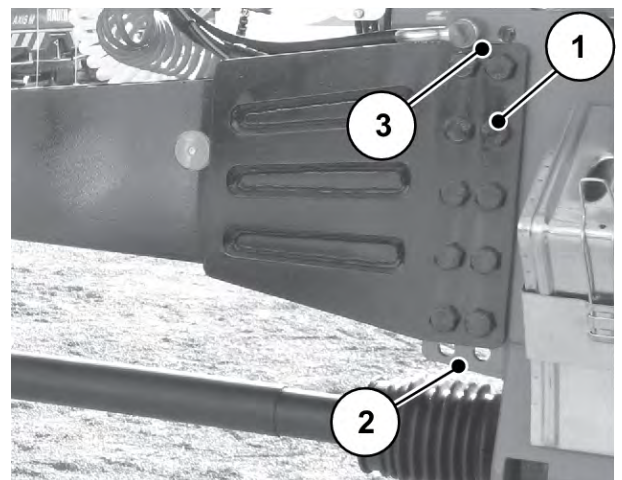

Fig. 19: Adjusting the height of the trailer unit

Use the existing spring washers DIN 127-24B only if they have not been destroyed or deformed during disassembly. Otherwise, use new spring washers.



Make sure to observe the tightening torque of 775 Nm for the trailer unit's screw connections.

6.6 Mounting the universal drive shaft on the machine

⚠ DANGER!

Danger of pulling in on the rotating universal drive shaft

Installing and removing the universal drive shaft while the motor is running may cause serious injuries (crushing, pulling into the rotating shaft).

- ▶ Turn the tractor engine off and remove the ignition key.
- ▶ Make sure that the universal drive shaft cover is in good condition.

⚠ WARNING!

Risk of injury and damage to property if an unsuitable universal drive shaft is used

The machine is equipped with a universal drive shaft that is designed according to the device and performance.

The use of incorrectly dimensioned or inadmissible drive shafts, for instance without guard or suspension chain, may cause personal injury or lead to damage to the tractor and/or the machine.

- ▶ Use only universal drive shafts approved by the manufacturer.
- ▶ Follow the directions in the operator's manual of the universal drive shaft manufacturer.

- ▶ Check the mounting position.

The drive shaft end that is marked with a tractor symbol must point to the tractor.

- ▶ Remove the spigot protection and grease the transmission spigot [1].
- ▶ Place the clamp [2] onto the transmission neck.

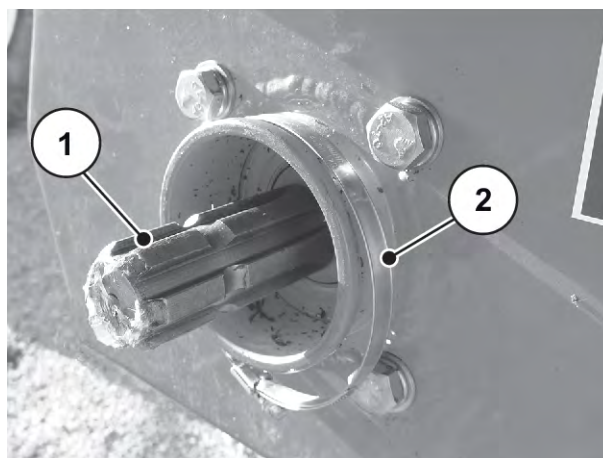

Fig. 20: Putting on the clamp



Since the universal drive shaft consists of telescopic elements and is heavy, we recommend hanging the universal drive shaft onto the machine before mounting.

- Keep the universal drive shaft horizontal.
- ▶ Place the universal drive shaft [3] into the safety chain [4] on the towing bar [1].
- ▶ Hang a chain link [4] into the hook [2].

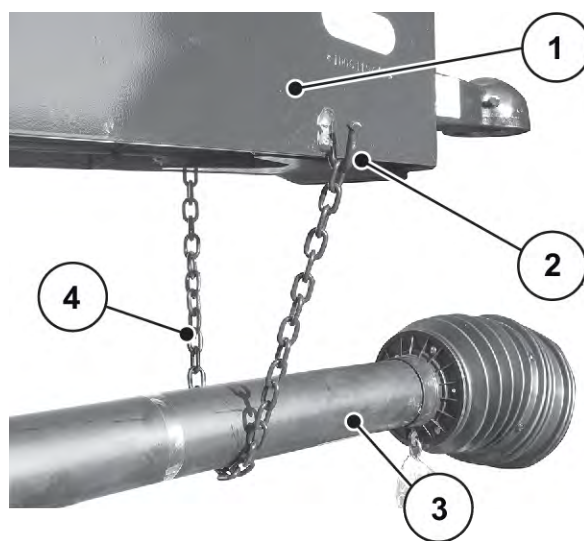

Fig. 21: Hanging the universal drive shaft onto the towing bar

- ▶ Pull the universal drive shaft guard backwards.
- ▶ Press the sliding pin [1].
- ▶ Slide the universal drive shaft on the transmission spigot until the sliding pin engages in the annular groove.
- ▶ Release the sliding pin.

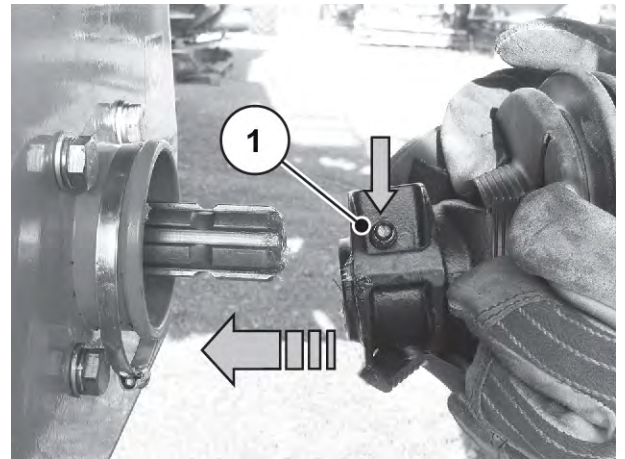

Fig. 22: Pushing the universal drive shaft onto the transmission spigot

- ▶ Push the universal drive shaft cover over the universal drive shaft.
- ▶ Place the universal drive shaft cover onto the transmission neck.
- ▶ Tighten the clamp.

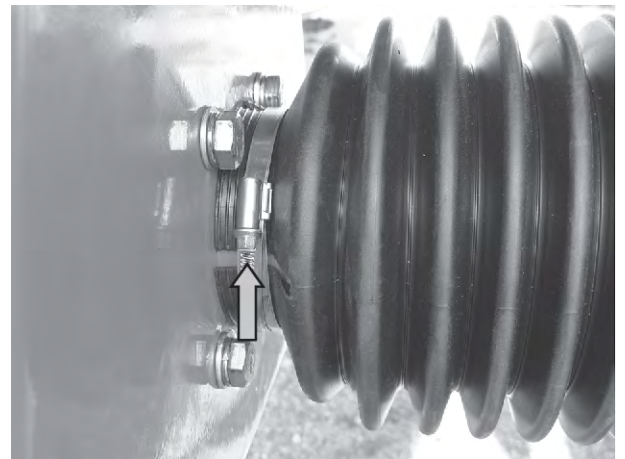

Fig. 23: Securing the universal drive shaft cover



The machine is equipped with a wide-angle universal drive shaft. When coupling to the tractor, please note that the pivot point of ball coupling/pin coupling should come to rest in a vertical axis to the pivot point of the wide-angle universal drive.

6.6.1 Dismounting the universal drive shaft

■ *Instructions for dismounting*

- Dismount the universal drive shaft in reverse order of mounting.
- Always place the dismounted universal drive shaft into the safety chain on the towing bar.



Fig. 24: Storing the universal drive shaft

6.7 Installing the machine at the tractor

6.7.1 Preconditions

DANGER!

Danger to life due to unsuitable tractor

Using an unsuitable tractor for the machine may result in severe accidents during operation or road travel.

- ▶ Only use tractors that comply with the technical requirements of the machine.
- ▶ Refer to the vehicle documents in order to check whether the tractor is suitable for the machine.

⚠ DANGER!**Danger to life due to carelessness or incorrect operation**

There is a crushing hazard that may result in fatal injury for persons standing between the tractor and the machine when the tractor approaches or the hydraulic system is actuated.

The tractor may brake too late or not at all because of carelessness or incorrect operation.

- ▶ Ensure that nobody is present in the hazard zone between the tractor and the machine.

⚠ DANGER!**Risk of tilting and rolling**

During filling, the unsecured machine may tilt or roll and cause severe personal injury and property damage.

- ▶ Hitch the machine only when the hopper is empty and the boom is folded in and secured.
- ▶ Secure the machine against moving using the parking brake and by placing wheel chocks under both wheels.

⚠ WARNING!**Risk of injury and property damage due to excessive static load**

Exceeding the maximum admissible static load of the drawbar compromises the steering and braking function of the machine and the tractor.

Persons may be injured. This may lead to severe damage at the machine, the tractor or to the environment.

- ▶ Observe the admissible static load of the tractor.
- ▶ Observe the admissible static load of the trailer equipment.

In particular check the following preconditions:

- Are both the tractor and the machine safe to operate?
- Does the tractor comply with the mechanical, hydraulic, and electrical requirements?
 - See 6.3 *Tractor requirements*
- Does the tractor comply with the requirements defined by the technical data of the towed machine (towed load, static load, etc.)?
- Is the machine securely positioned on level and solid ground?
- Is the machine properly secured against rolling?
- Is the height of the drawbar/ball coupling on the tractor adjusted correctly?
 - See 6.4 *Checking the height of the pin or ball coupling*
- Is the ISOBUS terminal installed in the tractor and functional?
- Is the combination of the connection equipment (towing eye - pin coupling or coupling bracket - ball coupling) admissible?

6.7.2 Mounting

■ Ball coupling

Variant A

- ✓ The PTO shaft is switched off.
- ✓ The holding-down clamp of the ball coupling is open.
- ▶ Start the tractor.
- ▶ Position the tractor at the machine.
- ▶ Precisely position the ball coupling of the tractor under the coupling bracket of the machine.
- ▶ Pull the hand brake of the tractor.
- ▶ Fold away the support stand. See 6.7.2.3 *Folding away the support stand*
- ▶ Switch off the tractor engine. Remove the ignition key.
- ▶ Close the holding down clamp.
 - ▷ Please refer to the instructions of the tractor manufacturer.

The connection is secured.

■ Pin coupling

- ✓ The PTO shaft is switched off.
- ✓ The hydraulic system is switched off.
- ✓ The pin coupling is open.
- ▶ Start the tractor.
- ▶ Position the tractor at the machine.
 - ▷ Make sure there is enough space between the tractor and the machine in order to be able to connect the drives and control elements.
- ▶ Pull the hand brake of the tractor.
- ▶ Fold away the support stand. See Fig. 25 *Folding away the support stand*
- ▶ Switch off the tractor engine. Remove the ignition key.
- ▶ Hang the towing eye into the tractor's pin coupling.
- ▶ Close the coupling pin.
 - ▷ Please refer to the instructions of the tractor manufacturer.

The connection is secured.

■ Folding away the support stand

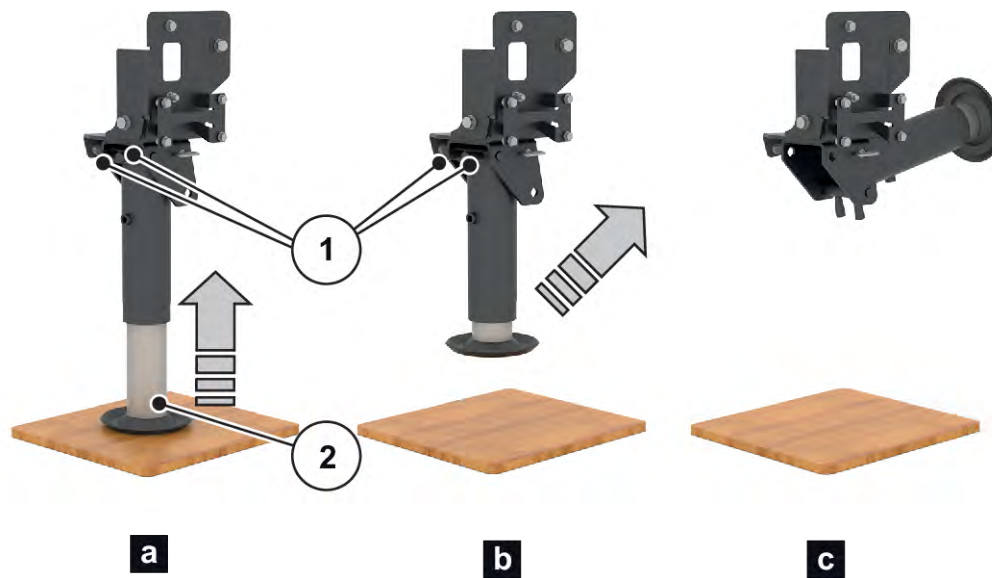

Fig. 25: Folding away the support stand

- ▶ Open the isolating valve:
 - ▷ Switch the tractor control unit to neutral so that the support foot can be raised.
The support stand is retracted automatically.
 - ▶ Release both locking bolts [2].
 - ▶ Fold away the support stand.
The locking bolt engages into the top position.
- The support stand is in the operating position.*

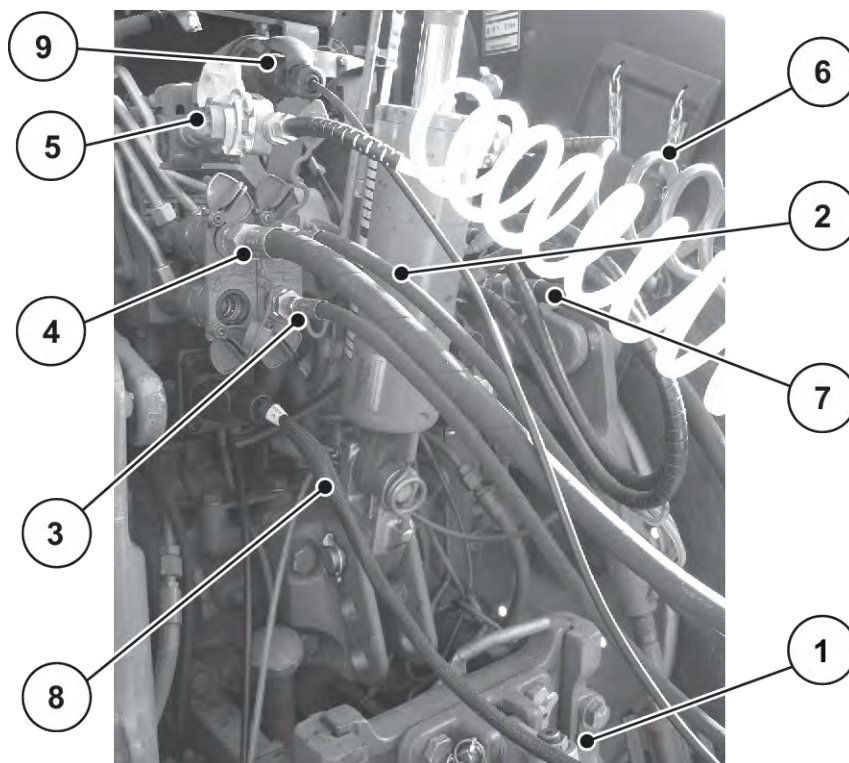

Fig. 26: Order of connecting the machine lines to the tractor

- | | |
|---|---|
| [1] Ball coupling (a variant with a pin coupling is also available) | [6] Pneumatic line of the compressed air tank (pneumatic brake) |
| [2] Hopper cover hydraulic line | [7] Return hydraulic line |
| [3] Hopper cover hydraulic line | [8] ISOBUS connector |
| [4] Control block hydraulic line | [9] Lighting connector |
| [5] Pneumatic control line (pneumatic brake) | |

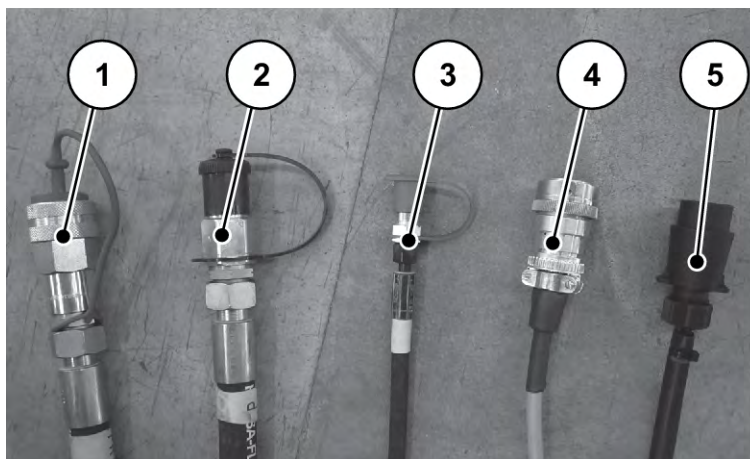

Fig. 27: Connection lines

- | | |
|------------------------------|---------------------------|
| [1] Pressure line | [4] ISOBUS connector plug |
| [2] Free return | [5] Lighting cable |
| [3] Load sensing signal line | |

- ▶ Move the tractor to the machine.
- ▶ Switch off the tractor engine. Remove the ignition key.
- ▶ Connect the hydraulic hoses of the hopper cover to the hydraulic control unit of the tractor.

See Fig. 26

6.8 Braking

The machine is equipped with a pneumatic braking system.

The arrangement of the braking system must conform to the applicable national regulations of the country in which the machine is used.

As a standard, the machine is equipped with an automatic parking brake.

The double release valve actuates or releases the parking brake and the operating brake.

Button position when the machine is parked: Red button [1] pulled out and black button [2] pushed in.

Button position when the machine is in operation: Red button [1] pushed in and black button [2] pulled out.



Fig. 28: Pneumatic brake

[1] Parking brake [2] Operating brake

Parking brake function	Operating brake function
The parking brake brakes the machine in parking position. If the red button [1] is pulled out, the parking brake is applied. If the red button is pushed in, the parking brake is released.	The black button [2] releases or actuates the machine's operating brake. If the black button is pulled out, the operating brake is applied and the emergency brake function is active. If the black button is pushed in, the operating brake is released and the emergency brake function is not active.

! WARNING!**Risk of injury due to the unsecured machine**

Until the machine is fully coupled, it may still roll and cause personal injury.

When coupling the machine, always observe the following sequence for the pneumatic lines:

- ▶ Ensure that nobody is present in the hazard zone.
- ▶ First, couple the yellow coupling head (brake line).
- ▶ Afterwards, couple the red coupling head (supply).

For commissioning, observe the following instructions:

- ▶ Prior to coupling, clean the seal rings and coupling heads of the pneumatic lines.
- ▶ Observe the order in which the components are connected: See *Fig. 26 Order of connecting the machine lines to the tractor*
- ▶ After coupling and prior to travel, check the braking system for tightness and proper function. To do so, engage the operating brake of the tractor.
- ▶ Do not drive with the coupled machine before the pressure gage in the tractor cabin indicates the correct operating pressure of the tractor.



For further information, please refer to the operator's manual of the tractor.

6.9 Establishing other connections

- ▶ Connect the lighting.
 - ▷ See *Fig. 26 Order of connecting the machine lines to the tractor*.
- ▶ Always check the lighting system prior to travel.
- ▶ Connect the camera to the terminal or tractor.
- ▶ Connect the ISOBUS cable to the ISOBUS connector of the tractor.



Refer to the operator's manual for the machine control unit.

6.10 Hydraulics system

The machine is equipped with an on-board hydraulic system.

There are two separate circuits:

- Circuit 1 drives an axial piston pump, which supplies the blower, via the universal drive shaft. The axial piston pump ensures a constant operating pressure at a universal drive shaft speed of 700 to 800 rpm.
- Circuit 2 supplies suspension, metering, and boom via the control block.



Observe chapter (→ *8 Spreading operation*) as well as the operator's manual for the electronic control units.

In the circuit that is used to fold the start section and the central section in the boom/parallelogram lifting device and in the axle suspension, diaphragm accumulators are used.

! WARNING!

Risk of injury due to hot surfaces

The accumulator body may heat up. There is a risk of burning.

- ▶ Only qualified personnel may perform work on the hydraulic parts and plug connectors.

■ **Connection diagram of the control block**

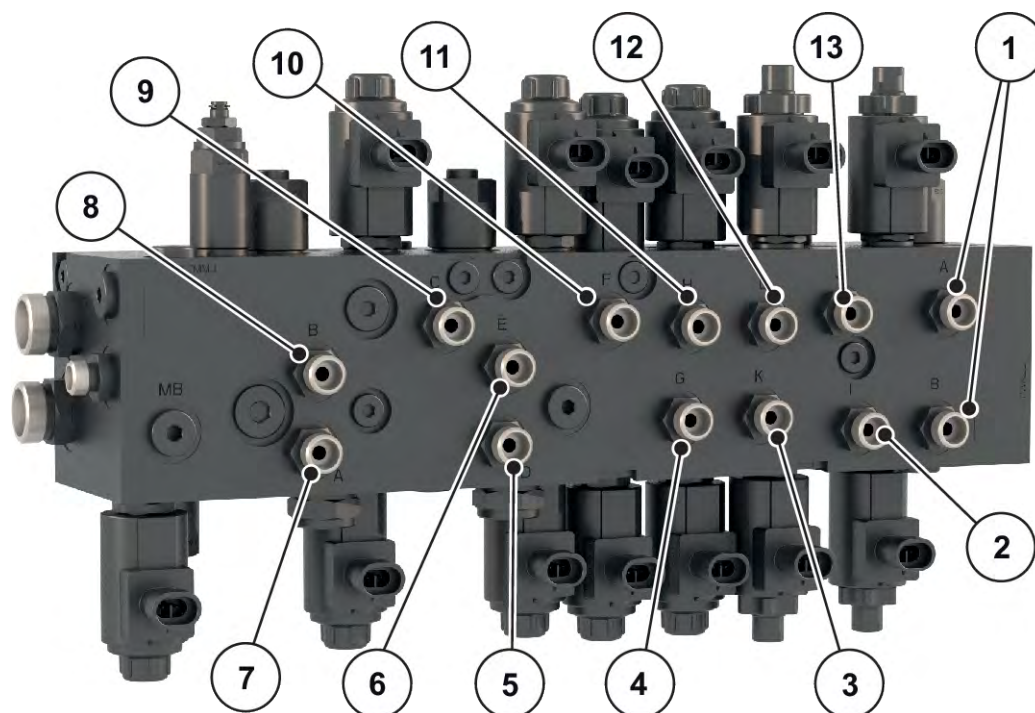

Fig. 29: Connection diagram of the control block

- | | |
|---|---|
| [1] Lifting/lowering | [8] Folding out the right start section |
| [2] Slope - lifting on left side | [9] Folding in the start sections |
| [3] Unlocking the pendulum frame | [10] Folding in the central sections |
| [4] Folding out the end sections | [11] Folding in the end sections |
| [5] Folding out the left central section | [12] Locking the pendulum frame |
| [6] Folding out the right central section | [13] Slope - lifting on right side |
| [7] Folding out the left start section | |

6.11 Filling the machine

⚠ DANGER!

Risk of tilting and rolling

During filling, the unsecured machine may tilt or roll and cause severe personal injury and property damage.

- ▶ Only fill the machine on even and firm ground.
- ▶ Make sure that the machine is coupled to the tractor prior to filling.
- ▶ Ensure that the parking brake is engaged.

⚠ DANGER!**Danger due to inadmissible overall weight**

Exceeding the overall weight can lead to breakage during operation and negatively affects the operational and road safety of the vehicle (machine and tractor).

Serious personal injury is possible as well as material and environmental damage.

- ▶ Always observe the information in chapter 4.3 *Technical specifications*.
- ▶ Before filling the hopper, determine the quantity to be filled.
- ▶ Do not exceed the permissible overall weight.

Requirements:

- The hydraulic system is switched on.
- ▶ Hydraulically open the hopper cover of the machine.
- ▶ Fill the machine evenly. For this purpose, use a front-end loader or a screw conveyor.
- ▶ Visually check the filling level in the hopper.
- ▶ After filling is completed, close the hopper cover.

The machine is filled.

6.12 Checking the filling level

⚠ WARNING!**Risk of injury due to falling from the platform**

The platform has a height of more than 1.50 m above ground. There is a risk of falling on the side of the steps. Severe injury may result.

- ▶ Move with care on the platform.
- ▶ Always keep the platform clean.
- ▶ Check the filling level through the inspection window in the hopper wall.

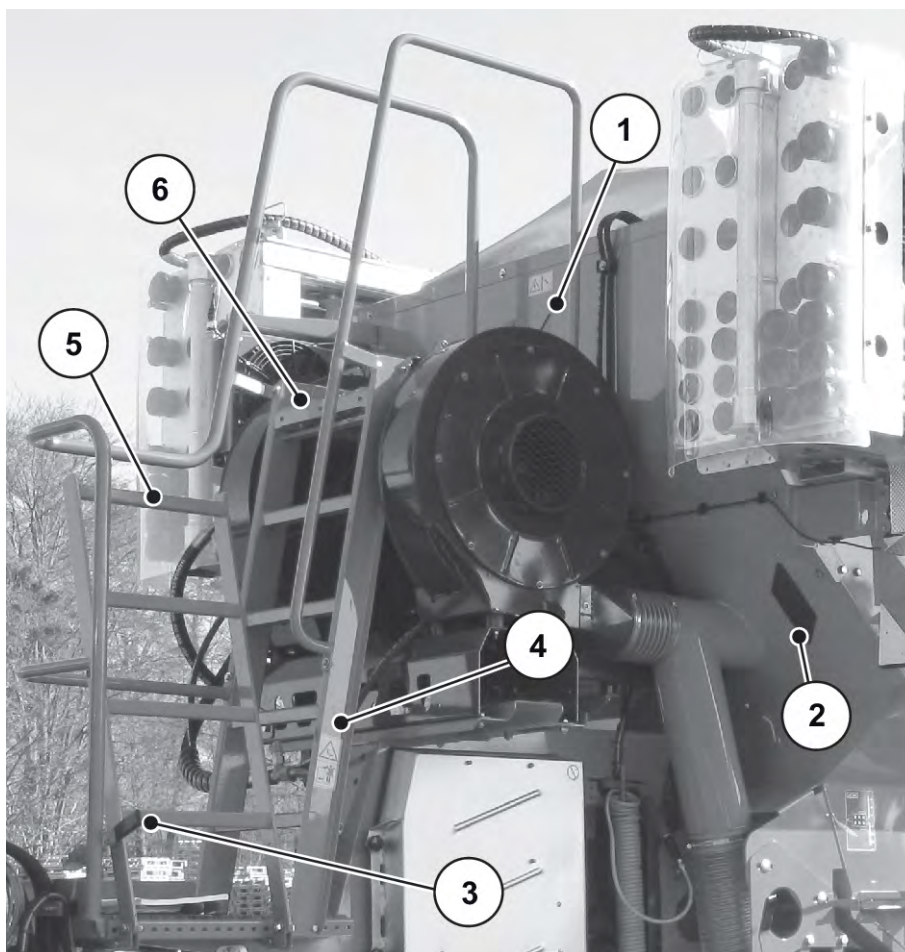

Fig. 30: Filling level check

- | | |
|--|-------------------|
| [1] Inspection window | [4] Steps |
| [2] Inspection window (1 on each side) | [5] Folding steps |
| [3] Locking lever | [6] Platform |

■ **Operating the steps**

- ▶ Lift the lever [1] with the hand.
The folding steps [2] are unlocked.
- ▶ Fold down the folding steps [2].

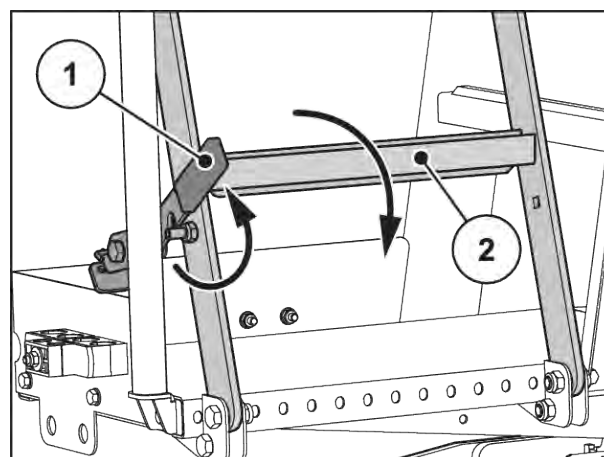

Fig. 31: Folding the steps out

- ▶ Carefully climb the steps up to the platform.
Use the handrails.
- ▶ Check the filling level using the inspection window.



Climb up only if the following preconditions are satisfied:

- The folding steps are folded out downwards.

During transport and while spreading with the machine, the folding steps must **always be folded up and locked**.

■ *Folding in the steps in transport position*

- ▶ Fold up the folding steps [2].
- ▶ Press the steps against the lever [1] until it engages firmly.

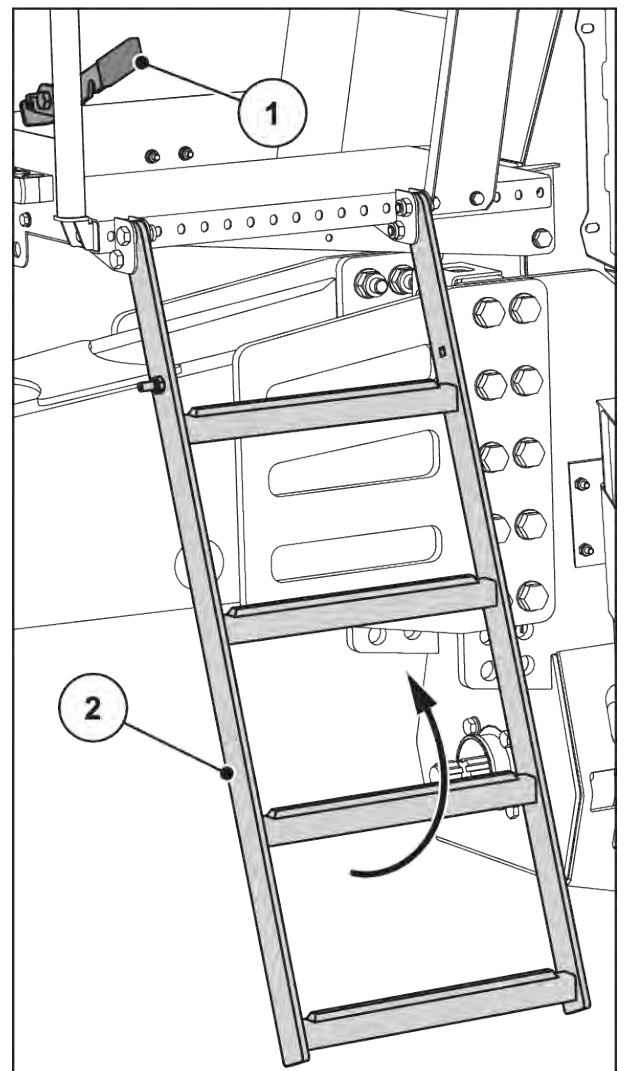

Fig. 32: Folding in the steps

6.13 Camera for rear view monitoring

The rear view camera offers a free view of the area behind the machine.

Check the correct setting of the camera at the ISOBUS terminal.



The lower third of the rear view camera must show the wheels.

If this is not the case, adjust the section of the image. This requires the support of a second person to observe the current view of the camera at the ISOBUS terminal in the tractor cab.

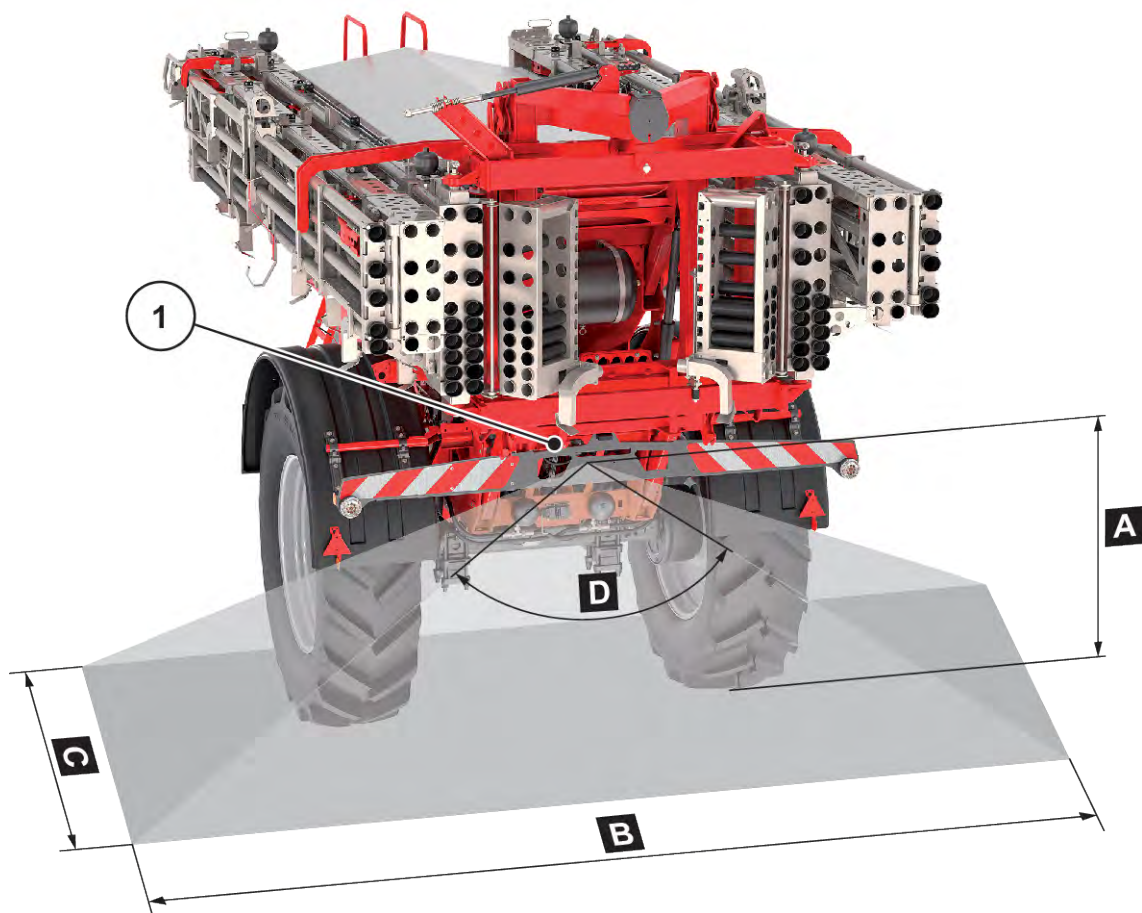

Fig. 33: Field of view of the rear view camera

- | | |
|---|---|
| [A] Installation height of the rear view camera:
Approx. 1.7 m | [C] Depth of the viewing field: Approx. 7.5 m |
| [B] Width of the viewing field: Approx. 6 m | [D] Viewing angle: 120° |
| [1] Rear view camera | |

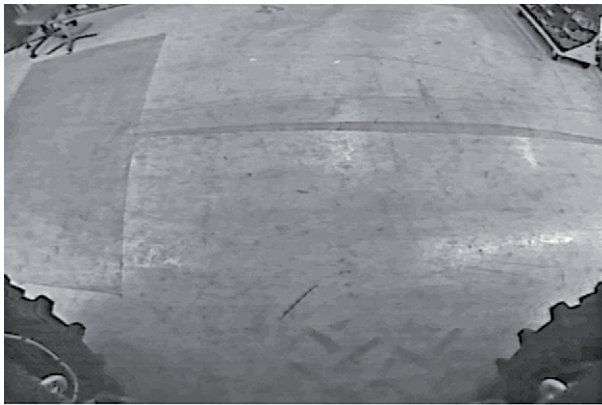

Fig. 34: Rear view camera screenshot

6.14 Switching on the machine control unit

Requirements:

- The machine control unit is correctly connected to the machine and the tractor.
 - For an example, see 6.7 *Installing the machine at the tractor*.
- The minimum voltage of **11 V** is guaranteed.



This chapter is limited to the description of the functionality of the electronic machine controller; it does not specify any particular ISOBUS terminal.

- The instructions for the operation of the ISOBUS terminal can be found in the relevant operator's manual.



- ▶ Start the machine control unit.
- ▶ The **Start screen** of the machine control unit appears.
- ▶ Note any warning message and acknowledge it with the Enter key.
- ▶ Subsequently, the machine control unit displays the **activation menu** for a few seconds.

The working screen then appears.



Detailed information on the use of the machine can be found in the operator's manual of the electronic machine control unit.

The operator's manual of the electronic machine control unit AERO ISOBUS is included in the scope of supply.

- If this is no longer to hand, contact the dealer or specialist workshop.

7 Calibration test

For precise control of the discharge amount, we recommend running a new calibration test every time the fertilizer material type is changed.

Perform a calibration test:

- before spreading for the first time
- If the fertilizer quality has changed significantly (moisture, high dust content, granulate damage)
- If a new fertilizer type is used

Perform the calibration test at a standstill with the engine running.



If the section is reduced, the calibration test should not be used to calibrate the machine. The application rate check can be performed even if the section is reduced.

Requirements:

- The machine is attached to the tractor.
- The hydraulic, electric, and pneumatic lines are connected.

As described below, always perform the calibration test on the first metering on the left front in the direction of travel. In the control unit, this corresponds to section no. 3 [1]. This section is the default factory setting and can be changed manually if necessary.

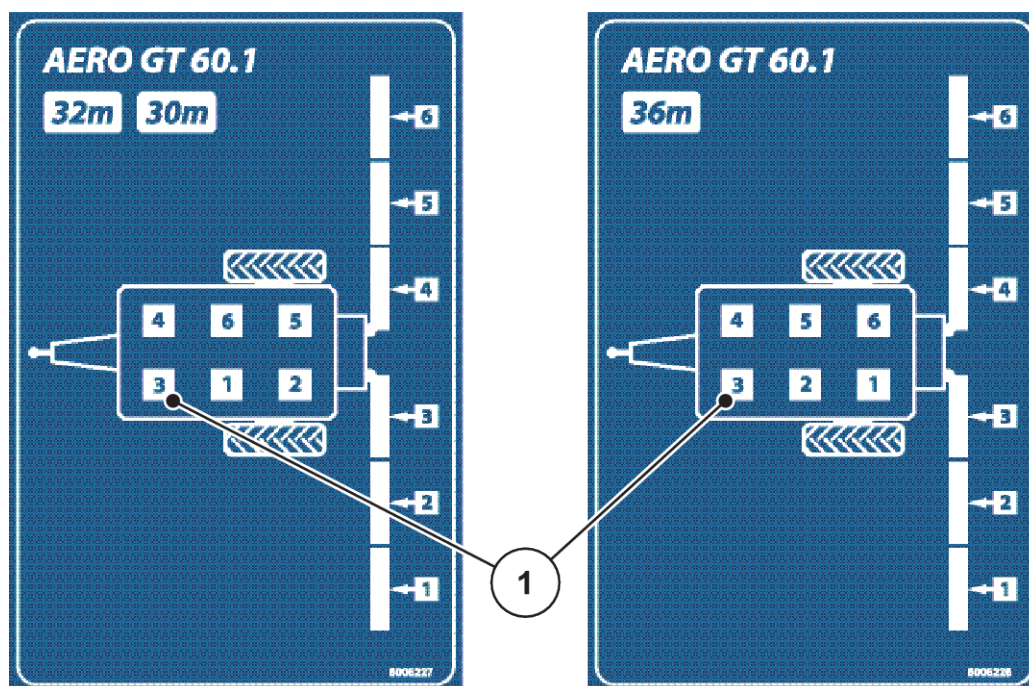

Fig. 35: Illustration of the sections on the boom-type mineral fertilizer spreader

7.1 Disconnecting the metering unit

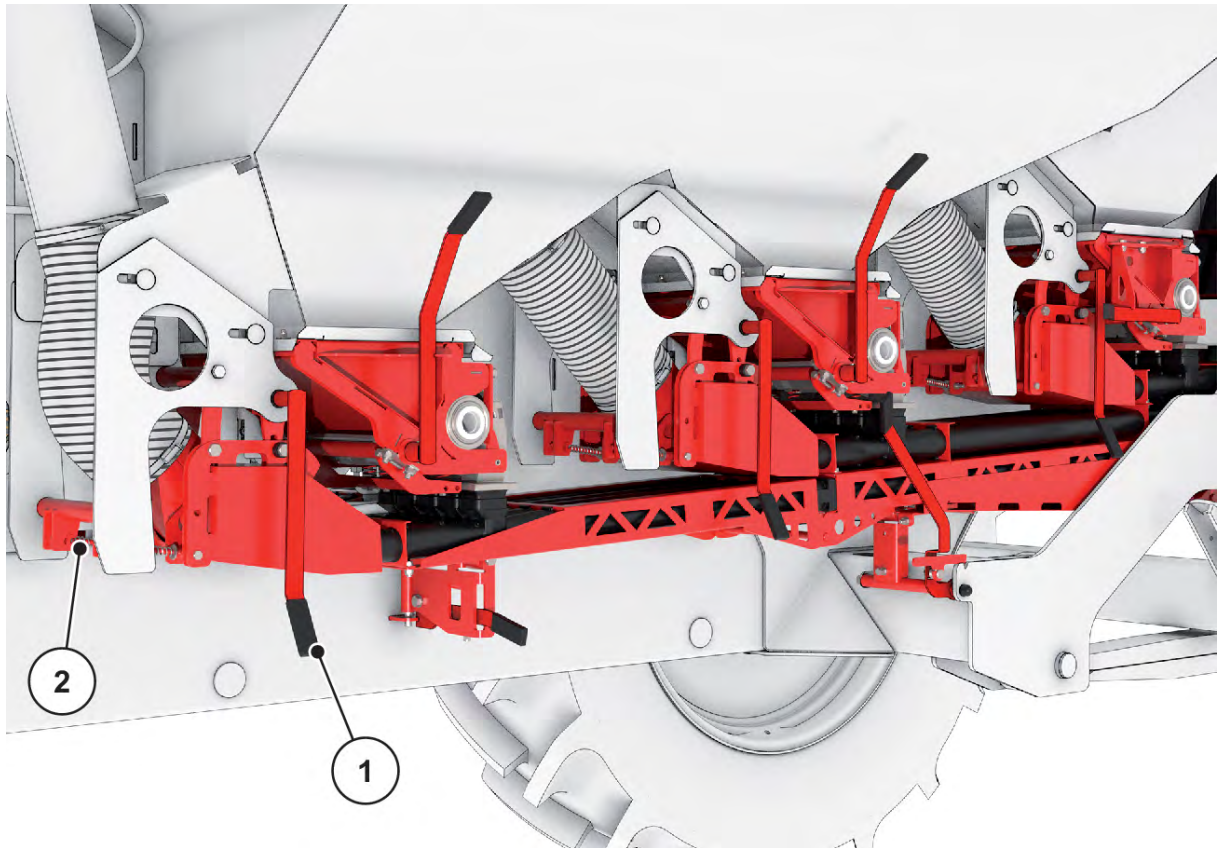

Fig. 36: Pressure chamber lever, left side of machine

- ▶ Move the lever of the front pressure chamber [1] on the **left** side forward.
The pressure chamber safety catch [2] falls downward and engages.
The connections between the pressure chamber and the injectors are open.

! WARNING!

Risk of injury due to loose and heavy air duct

Always secure the air duct when unlocking it. Otherwise, it folds down in an uncontrolled manner.

- ▶ Proceed with care.

- ▶ Slightly lift the air duct [1] with one hand.
- ▶ Use the other hand to lift the lever of the air duct bracket [2] and release it.

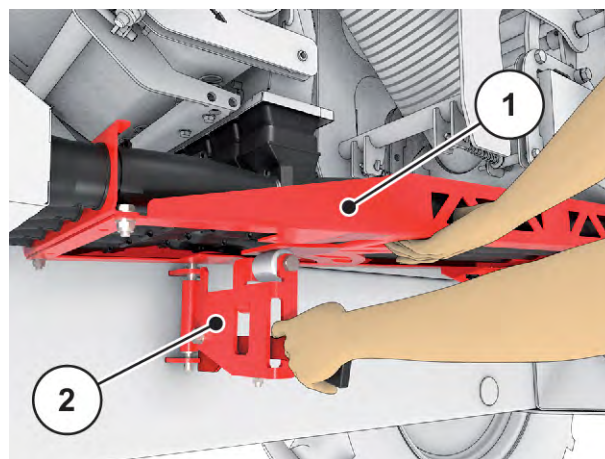

Fig. 37: Unlocking the lever of the air duct bracket

- ▶ Swivel the lever with the bracket [1] towards the rear until it engages in the locking mechanism on the frame.

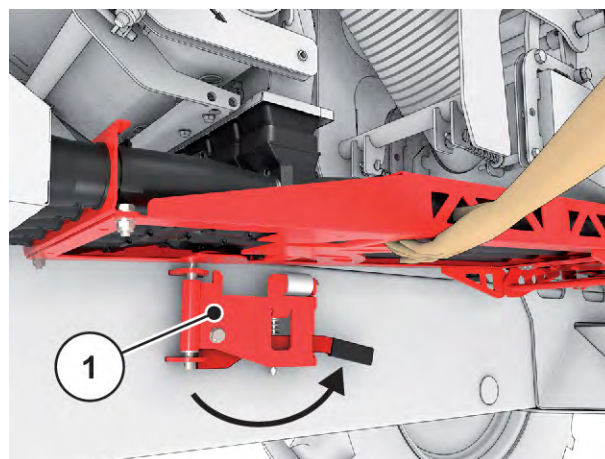

Fig. 38: Swiveling the bracket towards the rear

- ▶ Carefully lower the air duct.

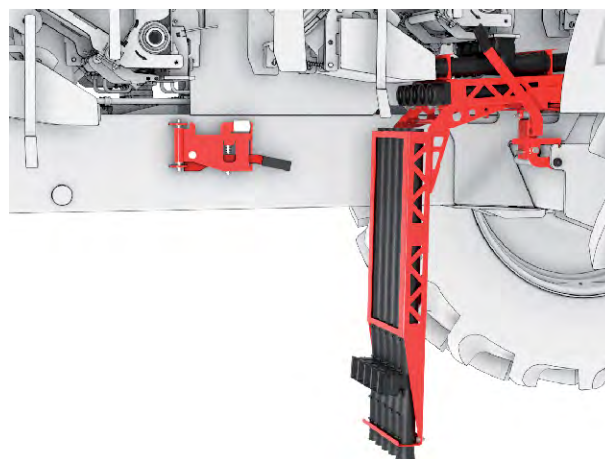

Fig. 39: Lowering the air duct

- ▶ Place the collection tray provided [2] underneath the metering system [1].
- ▶ Avoid a large gap between the outlet and the collection tray.

To do this, place the collection tray onto stacked pallets/boxes or into a wheel barrow underneath the metering system.

The machine is ready for the calibration test.

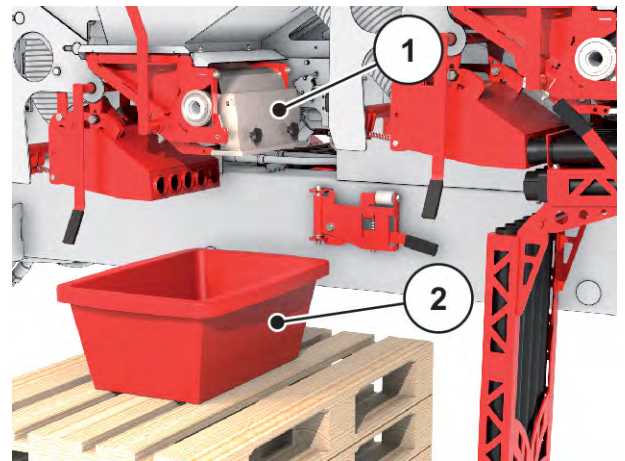

Fig. 40: Fertilizer collection tray underneath the metering system

7.2 Implementing the calibration test

! WARNING!

Risk of injury due to chemicals

Escaping fertilizer may lead to injury to eyes and nasal mucous membranes.

- ▶ Wear safety goggles during calibration.
- ▶ Follow the manufacturer's warnings when handling chemicals. Wear the recommended personal protective equipment (PPE).
- ▶ Before running the calibration test, ensure that all people leave the hazard zone of the machine.

The calibration test is used to calibrate the exact amount of fertilizer. Fertilizer must be filled into the hopper. Up to 4 calibration tests can be stored on the terminal/job computer.

Requirements:

- The metering unit is disconnected. (See 7.1 *Disconnecting the metering unit*)
- The machine control (ISOBUS terminal) is ready for operation.
- An adequately sized tray for collecting the fertilizer is located under the metering unit (minimum capacity 25 kg).
- The hydraulic system of the tractor is switched on (minimum oil flow rate 60 l/min).



Call up the Fertiliser settings > Start calibration menu.

- ▶
- ▶ Enter the new designation in the input field Fertiliser name.
- ▶ Press the OK button.

Page 2 appears.

- ▶ Select the desired section for the calibration test.
 - ▷ To do so, check the box under the section number.

The default procedure is to select the 3rd section.

- ▶ Enter the average working speed.

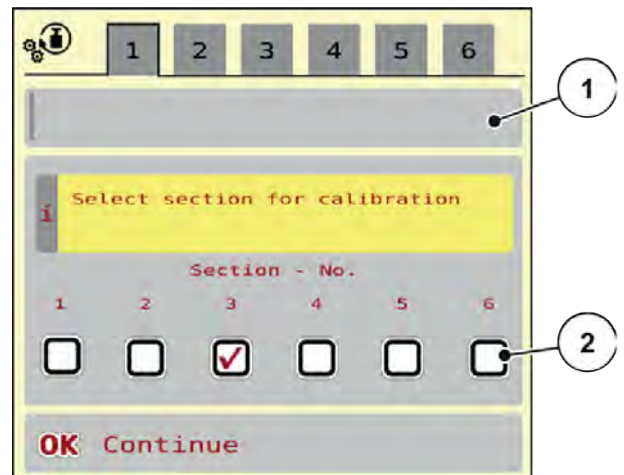

Fig. 41: Calibration test menu, page 1

- [1] Fertilizer designation the calibration test is performed
- [2] Selecting the section on which

! WARNING!

Risk of injury during calibration test

Rotating machine parts and discharged fertilizer could cause injury.

- ▶ Before starting the calibration, ensure that all requirements have been met.
- ▶ Observe the calibration chapter in the operator's manual for the machine.

- ▶ Press the OK button.

The new value is saved in the machine control unit.

The display switches to page 3.

The metering shaft now runs to fill the spreader tank and stops automatically after 15 s.

The display switches to page 4.

- ▶ Empty the fertilizer collection tray and then place it back under the metering unit.
- ▶ Press the OK button.

Page 5 appears.



- ▶ Press the start/stop function key.
- ▶ The calibration procedure now runs automatically until metering switches off independently after 80 s.
- ▶ The display switches to page 6.

- ▶ Weigh the collected fertilizer quantity again.
- ▶ Enter the collected fertilizer quantity.
The machine control uses the data to calculate the turns/kg.
- ▶ Press the OK button.

The newly calculated revolutions/kg have been adopted.

Revert back to the Fertiliser settings menu.

The calibration test has been performed and is therefore complete.

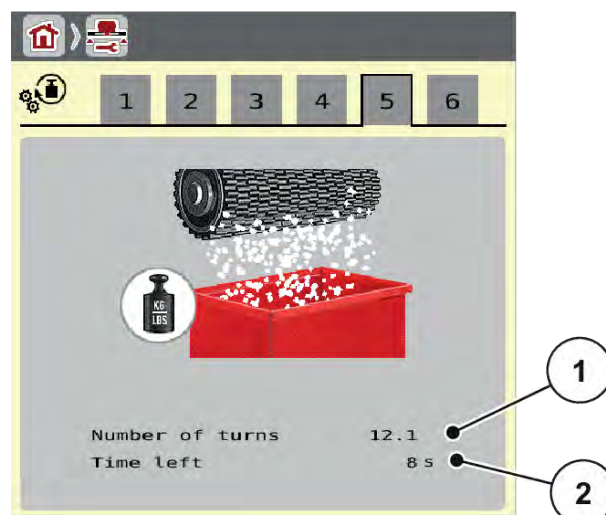

To retain the previously saved rotational speed, press the back button.

7.3 Assembling the metering unit

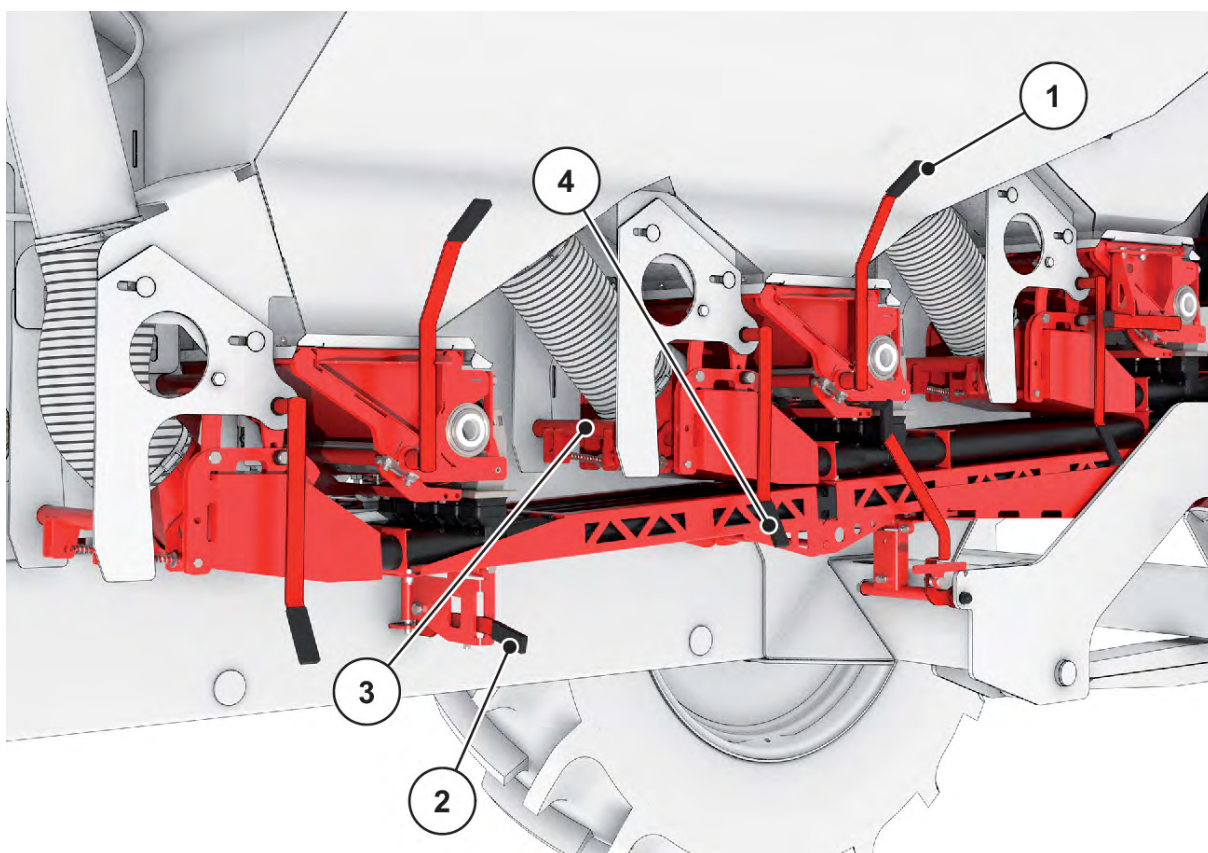

Fig. 42: Assembling the air duct

- ▶ Lift and secure the air ducts.
- ▶ Secure the air ducts with the lever [2] for the bracket.
- ▶ Unlock the locking mechanisms [3] of the pressure chamber safety catches.
- ▶ Use the control lever [4] to move the pressure chambers onto the air duct.

The machine is ready for spreading operation.

8 Spreading operation

8.1 General information



The working life of the machine depends to a large extent on how it is driven.

- ▶ Pay close attention to the machine settings. Even a slightly incorrect setting may adversely affect the spreading pattern.
- ▶ Check that your machine is working properly and that the application is sufficiently precise before every use of the spreader and during work (carry out a calibration test).
- ▶ Reduce the speed on uneven ground.
- ▶ Prevent the boom from hitting the ground.
- ▶ Special care is to be particularly taken when driving on uneven, soft ground (e.g., when entering fields, curbs).
- ▶ Drive with care through the headlands.
- ▶ Avoid sudden and rapid turns when driving uphill or downhill or across a slope.
 - ▷ The change in the center of gravity may increase the danger of tipping.
- The machine's operation depends on the driving speed. When the driving speed changes, the metering shaft speed is adjusted automatically.
- The control pump maintains the blower rpm at universal drive shaft speeds of 700 to 1000 rpm. In this range, you do not have to pay attention to maintaining the universal drive shaft speed while driving.

Claims for damage other than to the machine will not be accepted.

This also means that no liability will be accepted for damage resulting from spreading errors.

8.2 Instructions regarding the spreading operation

The modern technology and design of our machines and exhaustive, continuous testing in the factory's fertilizer spreader test system ensure that you will have a perfect spreading pattern.

In spite of the care taken during machine manufacture, deviations in fertilizer application or other faults are possible even with designated usage.

Reasons for this may be:

- Changes in the physical properties of the seeds or fertilizer (such as variable grain size distribution, variable density, grain size and surface, treatment, coating, moisture).
- Clumping and damp fertilizer
- Wind drift: stop spreading at high wind speeds.
- Blockages or bridge formation (e.g., due to foreign objects, bag residue, wet fertilizer, etc.).
- Uneven ground
- Deterioration of wear parts
- Damage from external causes
- Poor cleaning and care for preventing corrosion
- Incorrect drive speeds and forward speeds
- Neglecting to carry out the calibration test.
- Incorrect machine settings
- Baffles incorrectly fitted on the bends

The intended use of the machine includes compliance with the operating, maintenance, and service conditions in accordance with the manufacturer specifications. **Spreading** therefore always includes **preparation** and **cleaning/maintenance**.

- Carry out spreading operations in accordance with the sequence described below.

Preparation

- ▶ Install the machine at the tractor: 50
- ▶ Adjust the machine control settings
- ▶ Pour in fertilizer: 58
- ▶ Enter the application rate: Observing the operator's manual of the machine control

Spreading

- ▶ Fold out the boom in the field: 74
- ▶ Align the boom height and inclination: 75
- ▶ Engage the PTO shaft
- ▶ Start spreading (spreading START)
- ▶ Stop spreading (spreading STOP)
- ▶ Disengage the PTO shaft
- ▶ Align the boom height and inclination: 75
- ▶ Fold in the boom: 79

Cleaning/maintenance

- ▶ Discharge residual material: 80
- ▶ Decouple the machine from the tractor: 83
- ▶ Cleaning and maintenance: 92

8.3 Preparing the machine for driving

Requirements:

- The machine is securely coupled to the tractor. See 6.7.2 *Mounting*
- The support stand is folded away. See *Folding away the support stand - Page 53*
- The stairs are folded up and secured. See *Folding in the steps in transport position 61*

8.3.1 Disengaging the parking brake

Disengage the parking brake [1] only once the machine is coupled to the tractor and the pneumatic lines are connected.

- ▶ Remove the wheel chocks and insert them into the transport bracket.
- ▶ Press the button [1].

The parking brake is disengaged.



Fig. 43: Disengaging the parking brake

[1] Parking brake [2] Operating brake

8.3.2 Switching on the hydraulic system

- **Switching on the hydraulic system**
 - ▶ Switch on the ISOBUS terminal in the tractor cab, see additional instructions AERO ISOBUS chapter "Switching on the machine control" .
 - ▶ Switch on the hydraulic valve on the tractor for the boom-type mineral fertilizer spreader.



The hydraulic valve for the boom-type mineral fertilizer spreader must also be switched when driving on roads.

⚠ CAUTION!

Damage to the machine

Only operate the suspension in automatic mode. Otherwise, there is a danger of damage to the machine.

- ▶ Make sure that the tractor's hydraulic system and the machine control unit are switched on.

- ▶ Access the menu Hydr. axle suspension.





- ▶ Press the hydraulic axle AUTO function key.
The suspension cylinder moves the middle position.



The automatic suspension of the machine is activated.

The machine is now ready for use.

- ▶ **Prior to every use** check the operational and road safety of the overall vehicle according to the information in "**Traffic safety**" chapter.

8.4 Folding out the boom

⚠ DANGER!

Risk of death while the boom packages are folded in and out

The boom packages can injure people while they are swinging in and out. Note especially that the boom packages also require space behind the machine.

- ▶ Operate boom only if there is enough free space around the spreader.
- ▶ Only fold the booms in or out when the attached spreader is at a standstill.
- ▶ Ensure that there is no-one present in the hazard zone.



- ▶ Call up the Main menu > Boom folding menu.

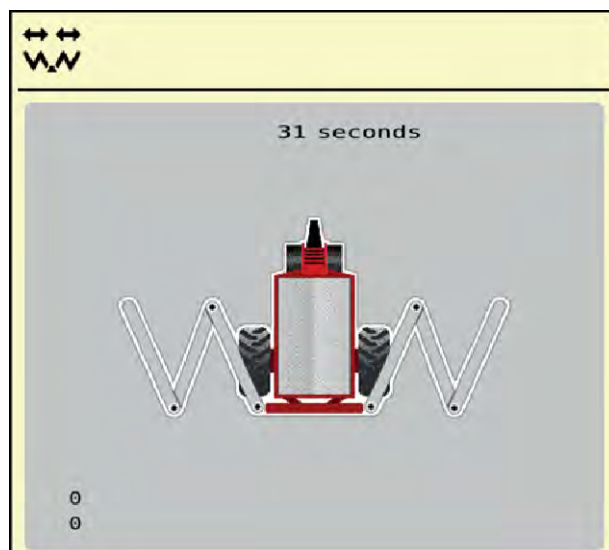

Fig. 44: Menu Boom folding



Always keep the boom in view whilst it is being folded.



- ▶ Press the **Lift boom** function key until the time has elapsed.
Open the transport lock.

The boom is in the highest position.



The long press of the button can be interrupted at any time.

- If necessary, press the **Lower boom** function key.
 - The boom is lowered.
 - Close the transport locks.
- If there is no obstacle in the folding area of the boom, press the **Lift boom** key again.
 - The folding procedure resumes.



- ▶ Press the **Fold out main sections** function key until the time has elapsed.
The central sections 2 are fully swung out on both sides.



- ▶ Long-press the unlock function key.
The Lock symbol appears on the menu screen.

The pendulum frame locking mechanism is unlocked.

The boom is ready for spreading.

NOTICE!

Damage due to closed locking mechanism

If the pendulum frame locking mechanism is closed, vibrations caused by driving are transmitted to the frame without suspension. This will take a heavy toll especially on the boom.

- ▶ Open the pendulum frame locking mechanism before driving with the spreader.



As soon as the pendulum frame is unlocked, spreading can start even if the end sections are folded in.



- ▶ Press the **Fold out end sections** function key until the boom end sections are fully folded out on both sides.

The end sections are folded out.

8.5 Manual adjustment of the boom



The control unit or the joystick can be used to manually adjust the boom height and inclination.

This can be done only with the relevant special equipment, see 4.4.3 *DistanceControl*.

⚠ DANGER!**Risk of injury due to insufficient operating height and inclination of the boom**

When one side of the boom is inclined, the other side inclines in the opposite direction. Collision of the booms with the ground, e.g., on slopes, can lead to severe personal injury. It can also cause severe damage to the machine.

- ▶ Ensure that nobody is present in the hazard zone.
- ▶ Do not set the operating height on the baffles of the innermost bend to less than 0.7 m above the existing plants.
- ▶ If the terrain is very uneven, select a higher operating height to prevent the boom from making contact with the ground.



Because the individual spreading angles overlap, a higher operating height does not have a negative effect on the spreading pattern.

The **DistanceControl** function (special equipment) automatically adjusts the height and the inclination. Manual adjustments are also possible if the **DistanceControl** function is deactivated or not available.

The corresponding keys are available in the main menu.

**Adjusting the height of the boom**

- ▶ Switch from the working screen to the **main menu**.
- ▶ Lift or lower the boom with the function keys [1].

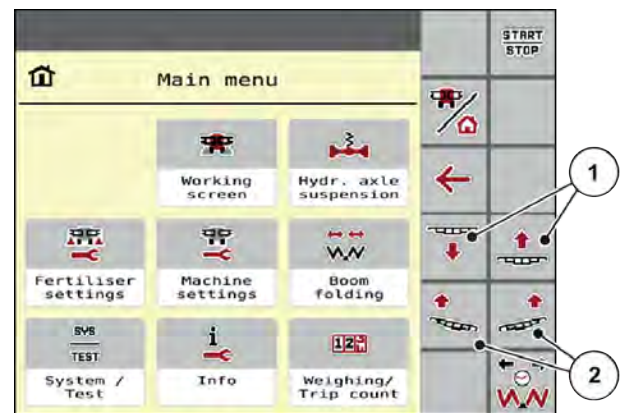

Fig. 45: Function keys for adjusting the boom inclination/height

**Adjusting the inclination of the boom**

- ▶ Switch from the working screen to the **main menu**.
- ▶ Use the function keys [2] on the left or right side to increase the inclination of the boom for the slope.

8.6 Fertilizer spreading

Before starting work, check to ensure that all requirements for a safe and economic spreading operation are met.

In particular, pay attention to the following points:

- Is the tractor/machine combination safe to operate?
- Are there people still within the spreading range? Direct them out of the hazard areas.
- Will the environmental conditions allow for a risk-free spreading operation? In particular under highly windy conditions.
- Do you know the territory and are you aware of any possible hazard spots?
- Is the correct fertilizer being used?
- The application rate has been entered into the control unit via the Fertiliser settings menu.
- Was a calibration test performed before using the machine?
- Is the drive shaft switched on (to ensure that blower is operating)?
- Is the hydraulic system of the tractor activated?
- Was the boom folded out and positioned with an incline?
- Was the automatic section control activated?
- Was the automatic control unit of the boom activated?

8.6.1 Spreading operation

- ▶ Switch on the universal drive shaft.
- ▶ If required, switch on the sections manually or automatically in the electronic control unit.
- ▶ Check the inclination of the boom.
 - ▷ See 8.5 *Manual adjustment of the boom*
- ▶ Switch to the working screen.
- ▶ Press the **Spreading ON/OFF** function key.



The spreading starts.



Spread the fertilizer on the field working exclusively to the tracking system until the end.

Set the section widths to prevent excessive application of fertilizer at the border areas.



- ▶ Press the **Spreading ON/OFF** function key.
- ▶ Switch off the universal drive shaft at the tractor.
 - The blower stops.*
- ▶ Stop the tractor in the track in a place that is as level as possible.

When the boom is folded out and in the operating position, the baffles must be inserted into the upper brackets on all bends.

Normal fertilizing

- ▶ Insert the baffle into the upper bracket facing downwards.



Fig. 46: Baffle in normal fertilizing mode



Late season fertilizing

The operating height on the baffles of the innermost bend must not be less than 0.7 m above the existing plants during late fertilizing.

- Adjust the height of the boom to the existing plants. See *Chapter 8.5 - Manual adjustment of the boom - Page 75*

8.6.2 Spreading with section control

The working width can be adjusted when activating or deactivating the sections. These settings can be configured directly in the working screen. They can be used to optimally adapt them to the field requirements during spreading operation.

Button	Spreading type
	Switching off the section from the left to the center
	Activating the section from the center to the left
	Switching off the section from the right to the center

Button	Spreading type
	Activating the section from the center to the right

- ▶ Press the function key several times until the desired working width is displayed.

8.7 Folding in the boom

DANGER!

Risk of death while the boom packages are folded in and out

The boom packages can injure people while they are swinging in and out. Note especially that the boom packages also require space behind the machine.

- ▶ Operate boom only if there is enough free space around the spreader.
- ▶ Only fold the booms in or out when the attached spreader is at a standstill.
- ▶ Ensure that there is no-one present in the hazard zone.



The machine control unit can no longer determine the position of the boom and the height of the pendulum frame once the folding menu has been exited.

- Before locking the boom, make sure to move it to the highest position.



Always keep the boom in view whilst it is being folded.



- ▶ Press the **Lift boom** function key until the time has elapsed.

The boom is in the highest position.



- ▶ Press the **Lock** function key for at least 3 seconds.

*The **Fold in end sections** symbol appears on the menu screen.*



- ▶ Press the **Fold in end sections** function key until the boom end sections are fully folded in on both sides.

The pendulum frame is locked.



- ▶ Press the **Fold in main sections** function key until the boom start sections and boom central sections are fully folded in on both sides.

The pendulum frame is locked.



- ▶ Press the **Lower boom** function key for at least 5 seconds:
The boom rests on the supports on the side of the hopper.
The transport locks are closed.

8.8 Discharging residual material

To protect against corrosion and blockages as well as to maintain the properties of the fertilizer, we recommend that the residual material is discharged every day after use. The fertilizer can then subsequently be re-used.

DANGER!

Danger of injury due to the running engine

Working on the machine with the engine running may result in serious injury caused by mechanical components and escaping fertilizer.

- ▶ Never perform the operations for discharging the residual quantity while the engine/drive shaft is switched on.
- ▶ Switch off the tractor engine.
- ▶ Remove the ignition key.
- ▶ Ensure that there is no-one present **in the hazard zone**.

Requirements:

- The machine is parked on even and solid ground and secured against tilting and rolling.
 - During discharge of residual material, the machine is coupled to the tractor.
- ▶ Expose the front air duct and lower it down (refer to chapter 7.1 *Disconnecting the metering unit*).
 - ▶ Carefully remove the front air duct and set it aside.

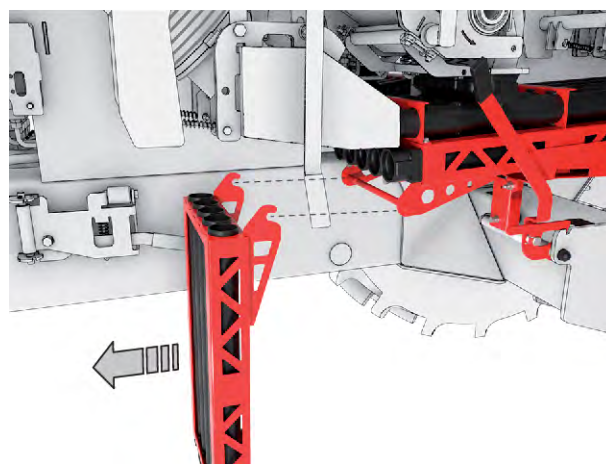

Fig. 47: Removing the air duct

- ▶ Move the lever of the central pressure chamber forward [1].

The pressure chamber is released from the rear air duct [2].

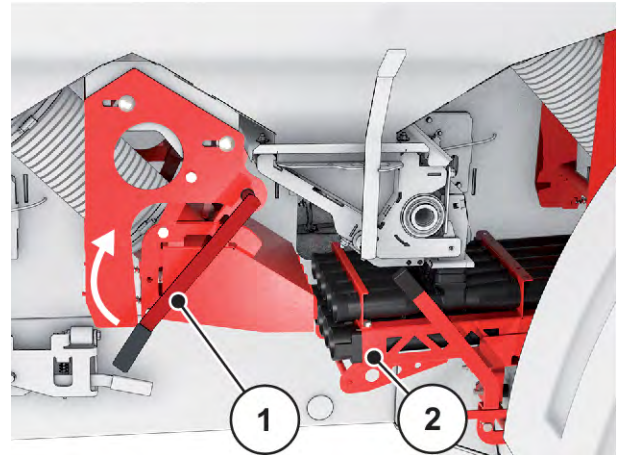

Fig. 48: Releasing the central pressure chamber

- ▶ Move the lever of the rear pressure chamber forward [1].

The pressure chamber is released from the rear air duct.

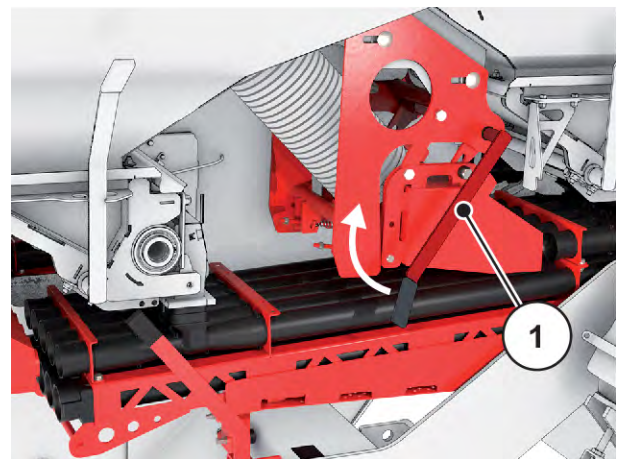

Fig. 49: Releasing the rear pressure chamber

- ▶ Release the safety catch [1].
- ▶ Move the lever of the rear air duct forward [2].

The air duct is unlocked.

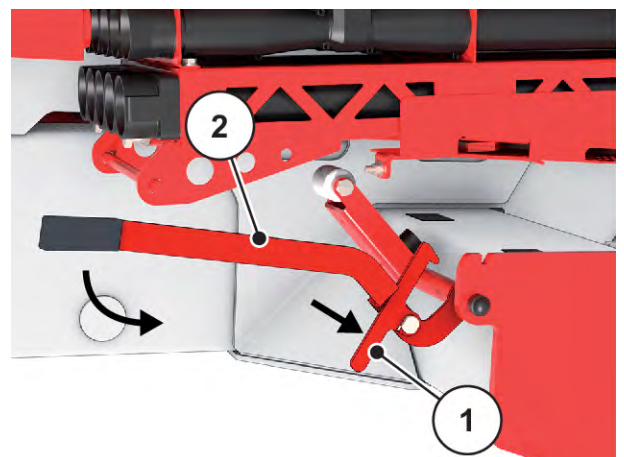

Fig. 50: Unlocking the rear air duct

- ▶ Pull out the rear air duct to the front and set it aside.

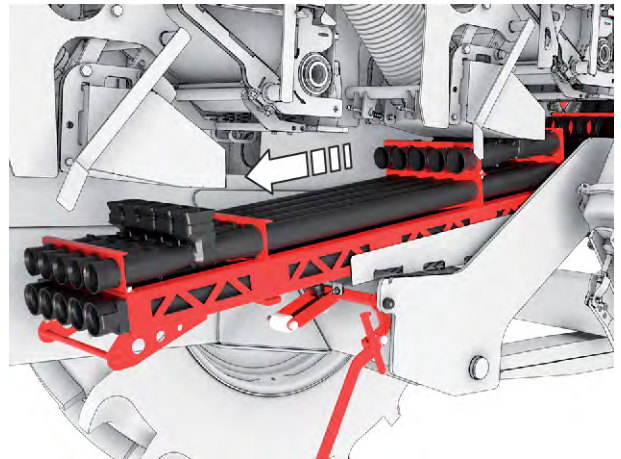

Fig. 51: Removing the rear air duct

- ▶ Place the spreader tank underneath the front metering unit.
- ▶ Move the lever of the front metering unit [1] backward.

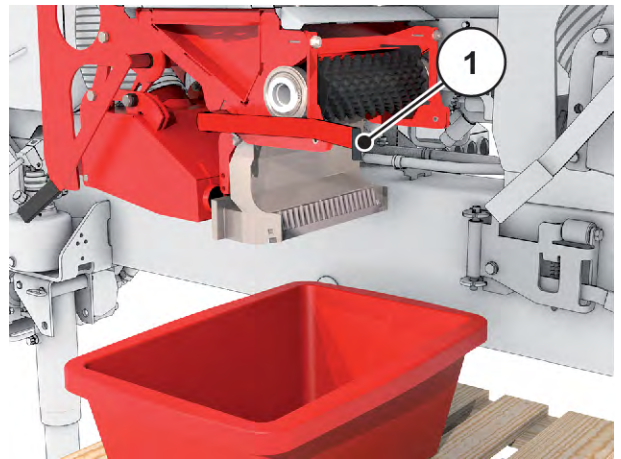

Fig. 52: Placing the spreader tank underneath

Draining procedure



- ▶ Press Start/Stop.
The metering shafts will rotate.

! WARNING!

Risk of injury due to rotating machine parts

Rotating metering shafts may catch and pull in body parts or objects. Contact with rotating machine components may cause bruises, abrasions and crushing injuries.

- ▶ Always stay outside the area of rotating metering shafts while the machine is running.
- ▶ Ensure that nobody is present in the hazard zone of the machine.

Fertilizer flow runs into the collection tray.



The emptying procedure can be interrupted at any time, for instance to empty the collection tray.

- Press Start/Stop.
- ▶ After completely emptying of the spreading material hopper, clean the machine.
 - ▷ See 10.2 *Cleaning the machine*
 - ▶ Reassemble the metering units.



Even though the spreader tanks have been emptied, they may still contain some fertilizer.

- We recommend to completely empty the machine at the end of the season or after spreading.

8.9 Parking and unhitching the machine

! WARNING!

Risk of tilting

The machine is a single-axle vehicle. One-sided loading in the rear may lead to tilting of the machine.

This may cause personal injury and property damage.

- ▶ Park the machine on even and solid ground.
 - ▶ In case of uneven loading of the machine in the rear, never decouple it from the tractor.
- Park the **machine only when it is empty.**
 - ▶ Park the vehicle train on even and solid ground.
 - ▶ Turn the tractor engine off and remove the ignition key.

Pneumatic brake system

- ▶ Pull the button [1] of the parking brake.
The parking brake is engaged.



Fig. 53: Engaging the manual parking brake

[1] Parking brake

[2] Operating brake

- ▶ Take out the wheel chocks from the transport bracket.
- ▶ Press the sliding pin [1] and fold open the wheel chocks.

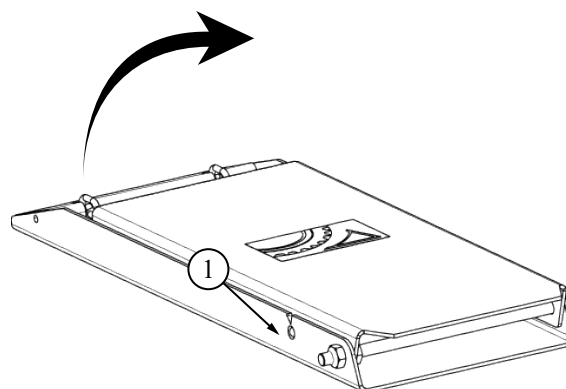

Fig. 54: Fold out the wheel chock

- ▶ Apply wheel chocks at both wheels.



Fig. 55: Positioning the wheel chock

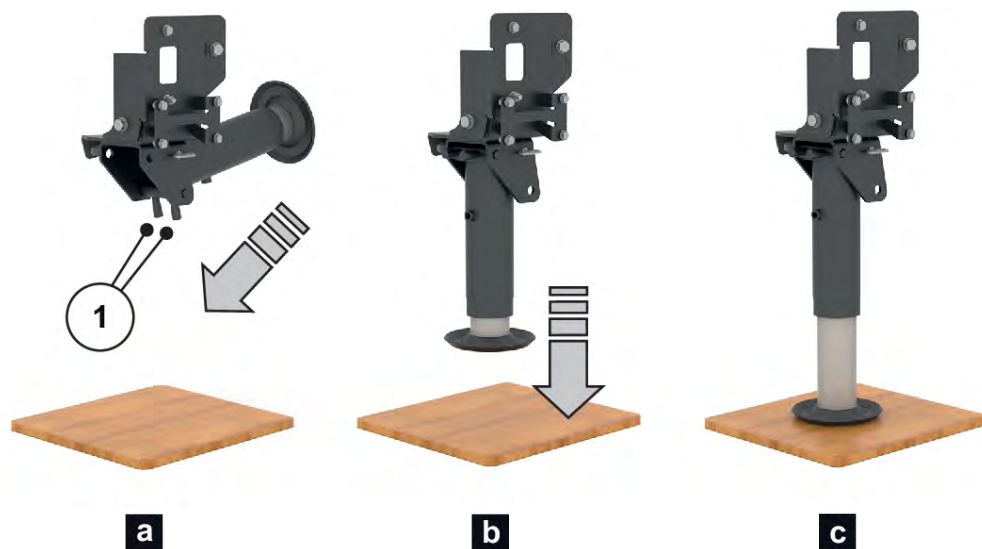

Fig. 56: Folding out the support stand

⚠ CAUTION!

Risk of injury due to support stand

When the support stand is released, it can fall down accidentally and cause hand and foot injuries.

- ▶ Make sure to hold the support stand with one hand when releasing the locking bolts.

Folding out the support stand

- ▶ Unlock the support stand by pushing together the locking bolts [1] and fold it down until the locking bolts have engaged in the bottom position.
- ▶ Extend the support stand through the tractor control unit until the machine has released the coupling point of the tractor.
- ▶ Close the isolating cock.

- ▶ When decoupling the machine, **always first decouple the red coupling head** (supply) and then the **yellow** coupling head of the pneumatic braking system.
- ▶ Disconnect the electrical connections from the tractor.
- ▶ Protect all connectors with dust caps.
- ▶ Decouple the universal drive shaft from the tractor.
- ▶ Put the hydraulic system of the tractor into a depressurized state (**floating position**).
- ▶ Disconnect the hydraulic connections from the tractor.
- ▶ Decouple the machine from the tractor.

The machine is decoupled and parked.

9 Faults and possible causes

WARNING!

Risk of injury due to incorrect troubleshooting

Delayed or incorrect repairs by unqualified personnel may result in severe personal injury as well as in damages to the machine and the environment.

- ▶ Any faults occurring must be repaired **immediately**.
- ▶ Troubleshooting may be performed by personnel who are appropriately **qualified**.

Troubleshooting requirements

- Switch off the tractor engine and lock it to prevent unauthorized starting.



Before troubleshooting the faults, refer to the warning instructions in chapter 3 *Safety* and 10 *Maintenance and service*.

Fault	Possible cause	Measure
The displayed speed for the metering shaft on the operating screen is "0".	The encoder on the front LEFT or RIGHT metering drive is defective.	▶ Replace the encoder.
	The hydraulic line to the drive motor is defective.	▶ Replace the hydraulic line.
	Broken cable on the wiring harness to the encoder.	▶ Visit an authorized workshop.

Fault	Possible cause	Measure
The typical working speed is not longer reached.	The moisture content in the fertilizer has increased. This caused the flow characteristics to deteriorate.	<ul style="list-style-type: none"> ▶ Close the hopper cover. ▶ Empty the hopper of remaining fertilizer. ▶ Fill in new fertilizer.
	The output and flow rate on elements conveying air and fertilizer is reduced.	<ul style="list-style-type: none"> ▶ Make sure that the pressure chambers are firmly connected to the air ducts. ▶ Check the fertilizer conveying hoses and ducts for leaks and replace them, if necessary. ▶ Check the sealing funnel between the air ducts and the boom segments and replace them, if necessary. ▶ If necessary, remove sticky and/or clogged moist fertilizer in the injector and bend.
The target application rate does not match the actual application rate.	Wear or damage on the metering shafts affect the metering accuracy.	<ul style="list-style-type: none"> ▶ Make sure that the distance between the cam wheel and the spreader tank is 3 mm. <i>See 10.4 Check metering unit and application</i> ▶ Cam wheels that are broken due to foreign objects at the metering shafts must be replaced. ▶ Check the hopper filling input under "Settings/information" and correct them, if necessary.

Fault	Possible cause	Measure
The boom packages do not make contact in the transport position.	The pretension of the hydraulic cylinders is not sufficient.	<ul style="list-style-type: none"> ▶ Check the clearance between the disc spring and the pressure plate on the hydraulic cylinder and adjust it, if necessary. ▶ Check the joint eyes on the hydraulic cylinder and replace them, if necessary. ▶ In case of a leak in the hydraulic cylinder, replace the sealing package.
The slope cannot be adjusted.	The boom is locked on the pendulum frame when it is folded out.	<ul style="list-style-type: none"> ▶ Check the pendulum frame locking mechanism and open it using the terminal in the Boom folding menu, if necessary.
The metering shaft of a section does not stop after it has been switched off.	The hydraulic valve on the metering drive is without function.	<ul style="list-style-type: none"> ▶ Check the valve and replace it, if necessary.
	Power supply, plug connectors, and/or wiring harness to the switching solenoid on the drive motor defective.	<ul style="list-style-type: none"> ▶ Visit an authorized workshop.
The metering shaft cannot be switched back on.	The hydraulic valve on the metering drive is without function.	<ul style="list-style-type: none"> ▶ Check the valve and replace it, if necessary.
	Power supply, plug connectors, and/or wiring harness to the switching solenoid on the drive motor defective.	<ul style="list-style-type: none"> ▶ Visit an authorized workshop.
The noise level on the blower drive is higher.	Rubber elements are defective.	<ul style="list-style-type: none"> ▶ Close rubber element in the claw coupling on the blower drive. ▶ Check rubber element in claw coupling and replace it, if necessary.

Fault	Possible cause	Measure
The pendulum frame locking mechanism does not secure the boom correctly.	Slope cylinder is retracted or extended all the way.	▶ Adjust the boom to the horizontal position before locking the pendulum frame.
	Installation length on the hydraulic cylinders of the locking mechanism not correct	▶ Check the adjustment of the joint eyes on the hydraulic cylinders and correct it, if necessary.
	Hydraulic lines to the hydraulic cylinders defective	▶ Replace the hydraulic line.
	Leakage in the hydraulic cylinder	▶ Replace the sealing package of the hydraulic cylinder.
	Switching valve for locking mechanism in control block defective	▶ Visit an authorized workshop.
	Power supply, plug connectors, and/or wiring harness to the switching solenoid defective	▶ Visit an authorized workshop.
Transport lock does not secure the boom correctly	Installation length on the hydraulic cylinder of the locking mechanism not correct	▶ Check the adjustment of the joint eyes on the hydraulic cylinder and correct it, if necessary.
	Check the hydraulic lines to the hydraulic cylinder.	▶ Replace the hydraulic line.
	Leakage in the hydraulic cylinder	▶ Replace the sealing package of the hydraulic cylinder.
	Switching valve for locking mechanism in control block defective	▶ Visit an authorized workshop.
	Switching valve (manual button) on boom support plate defective	▶ Visit an authorized workshop.
	Power supply, plug connectors, and/or wiring harness to the switching solenoid defective	▶ Visit an authorized workshop.

Fault	Possible cause	Measure
The support stand cannot be extended far enough.	Support stand is not fully extended.	▶ Check the oil volume in the oil reservoir and top it up, if necessary.
The brake on the machine does not release while the tractor is running.	Air losses due to leakages in the brake system.	▶ Visit an authorized workshop.
The lighting system does not work.	Power supply, plug connectors, and/or wiring harness defective	▶ Visit an authorized workshop.

10 Maintenance and service

10.1 Safety



Take particular note of the warning instructions in chapter 3 *Safety*.

Take **particular note of the instructions** in section 3.8 *Maintenance and service*.

Take note of the following instructions:

- Welding and work on the electrical and hydraulic systems is to be carried out by qualified technicians only.
- There is a **risk of tipping** when working at the lifted machine. Always secure the machine using suitable supports.
- Always use **both** eyelets in the hopper for lifting the machine by means of hoisting gear.
- There is a risk of **crushing and shearing** at power-operated components. Make sure that there is no one in close proximity to the moving parts during maintenance.
- Spare parts must at least comply with the technical standards specified by the manufacturer. This is assured with original spare parts.
- Before starting any cleaning, maintenance, or repair work, and when troubleshooting, switch off the tractor's engine, remove the ignition key, and wait until all moving parts of the machine have come to a stop.
- By controlling the machine with an operating unit, additional risks and hazards due to externally operated components may arise.
 - Disconnect the power supply between the tractor and the machine.
 - Disconnect the power supply cable from the battery.
- Repairs may **ONLY be carried out by instructed and authorized workshops**.

DANGER!

Danger of injury due to running engine

Working on the machine with the engine running may result in serious injury caused by mechanical components and escaping fertilizer.

- ▶ Wait until all moving parts have come to a complete stop before making any adjustments or performing maintenance work.
- ▶ Switch off the tractor engine.
- ▶ Remove the ignition key.
- ▶ Ensure that nobody is present **in the hazard zone**.

⚠ DANGER!**Danger of injury due to running engine**

Working on the machine with the engine running may result in serious injury caused by mechanical components and escaping fertilizer.

- ▶ Wait until all moving parts have come to a complete stop before making any adjustments or performing maintenance work.
- ▶ Switch off the tractor engine.
- ▶ Remove the ignition key.
- ▶ Ensure that nobody is present **in the hazard zone**.

■ **Maintenance plan**

Task	Before operation	After operation	After the first X hours	After the first X hours	Every X hours	Every X hours	Every X hours	Every X hours	Every X hours	Every X hours	Daily	Weekly	Every X weeks	Quarterly	Yearly	Every X years	Every X years	At the beginning of the season
Value (X)			10	50	20	50	100	200	1000				2			2	6	
Cleaning																		
<i>Cleaning</i>	X	X																
<i>Air tank</i>										X								
Lubrication																		
<i>Universal drive shaft</i>																		X
<i>Joints, bearings: Pendulum frame</i>						X												X
<i>Joints, bearings: Boom</i>						X												X
<i>Joints, bearings: Parallelogram</i>						X												X
<i>Joints, bushes</i>						X												X
<i>Joints, bearings: Other components</i>						X												X
Check																		
<i>Wear parts</i>							X											X

Task	Before operation	After operation	After the first X hours	After the first X hours	Every X hours	Every X hours	Every X hours	Every X hours	Every X hours	Daily	Weekly	Every X weeks	Quarterly	Yearly	Every X years	Every X years	At the beginning of the season
Value (X)			10	50	20	50	100	200	1000			2			2	6	
Screw connections	X		X														X
Distance between cam wheel and spreader tank						X											X
Boom segments: Vertical orientation																	X
Boom segments: Horizontal orientation																	X
Holding force of the boom segments																	X
Holding force of the boom segments																	X
Electric fuses			X					X									X
Electric lines	X			X				X									X
Lighting equipment					X					X							
Electronic control unit	X			X				X									X
Hydraulic hoses	X					X											X
Nitrogen tank	X														X		X
Hydraulic cylinders	X										X						
Oil level										X							
Oil level in the transmission of the Vario drive			X					X									X
Hydraulic component	X																X
Hydraulic motors	X																X
Braking system	X													X			

Task	Before operation	After operation	After the first X hours	After the first X hours	Every X hours	Every X hours	Every X hours	Every X hours	Every X hours	Daily	Weekly	Every X weeks	Quarterly	Yearly	Every X years	Every X years	At the beginning of the season
			10	50	20	50	100	200	1000			2			2	6	
<i>Slack adjuster</i>														X			
<i>Brake pad</i>									X				X				X
<i>Axle suspension</i>	X																X
<i>Axle suspension</i>	X																
<i>Tires</i>	X											X					X
<i>Wheels</i>	X																X
<i>Bearing clearance of the wheel hub</i>				X			X										
Replacement																	
<i>Hydraulic hoses</i>																X	
<i>Gearbox</i>				X			X							X			
Changing fluids																	
<i>Vario drive</i>				X			X							X			

10.2 Cleaning the machine

■ Cleaning



Spreading material and dirt promote corrosion. Although the machine components are made from corrosion-free material, we recommend that you clean the machine immediately after each use to maintain its value.

- ▶ If available, fold up the protective grids in the hopper (depending on the machine).
- ▶ Clean oiled machines only at washing points fitted with an oil separator.
- ▶ When cleaning with high-pressure water, never aim the water jet directly at warning signs, electrical equipment, hydraulic components, and plain bearings.
- ▶ Preferably clean the machine using a gentle water jet.
- ▶ Especially clean the air ducts, injectors, and bends.
- ▶ After cleaning, treat the **dry** machine, **especially the stainless steel parts**, with an environmentally friendly anti-corrosion agent.
 - ▷ A suitable polishing kit can be ordered from authorized dealers for treating rust spots.
- ▶ After cleaning, spray the **dry** hydraulic fittings with cavity protection wax and allow to dry.
 - ▷ Order cavity protection wax from your authorized dealer.

10.3 Wear parts and screw connections

10.3.1 Checking wear parts

■ *Wear parts*

Wearing parts are: **Hoses, metering shafts, drive belts, hydraulic hoses**, and all plastic parts.

Plastic parts are subject to a certain aging process even under normal spreading conditions. Plastic parts are, e.g., **protective grid locks**.

- Inspect wear parts on a regular basis.
- ▶ Replace these parts if they show signs of wear, deformation, holes, or ageing. Otherwise, the spreading pattern will not be correct.
 - ▷ The durability of wearing parts depends, among other things, on the material being spread.
- ▶ Have the condition of the machine and particularly the attached components, hydraulic system, metering elements, bends, hoses, and baffles checked by your specialist dealer after each season.
- ▶ Replace worn parts in time to prevent consequences resulting from damage.

10.3.2 Checking the bolted connections

■ *Screw connections*

The screw connections are tightened with the necessary torque and secured at the factory. Oscillations and vibrations, particularly during the initial hours of operation, can cause screw connections to become loose.

- ▶ Check that all screw connections are tight.



Some of the components have self-locking nuts.

Always use new self-locking nuts when assembling these components.



Observe the tightening torques for the standard screw connections.

- See 13.2 *Torque value*

10.4 Check metering unit and application

■ *Distance between cam wheel and spreader tank*

For exact metering and discharge, the metering elements must be properly adjusted and free from fertilizer residues.



Cam wheels that are broken due to foreign objects at the metering shafts must be replaced. See 10.5 *Replacing and removing the metering shaft*

Check further conveying elements for wear:

- Check air ducts, sealing funnel, bends, fertilizer hoses, and baffles for wear.
- These parts must be replaced if worn due to wear.



The correct spreading rate is checked by a calibration test. See 7.2 *Implementing the calibration test*

10.5 Replacing and removing the metering shaft

Replace the metering shaft

- ▶ Release the four nuts so that the metering unit can be moved transversely to the direction of travel.
- ▶ Now pull the metering unit towards the outside up to the stop.
- ▶ Next, fold the metering tank down and away using the clamping lever.



- ▶ Now release the nuts of the metering shaft bracket [1] and fold down the brackets.

The metering shaft can now be removed.



Since the metering shafts are often seated very tightly in the bracket, an assembly pry bar or a shaft may be inserted into the metering shaft and used to pry it out for easier removal.



Replacing the cam wheels

- ▶ Remove the bush.
- ▶ Pull off the Nilos ring.
- ▶ Pull off the bearing [1].
- ▶ Next, remove the first circlip [3].
- ▶ Remove the stop of the metering tank [2].
- ▶ Now only the second shaft circlip [3] must be removed.
- ▶ Pull off the cam wheels.

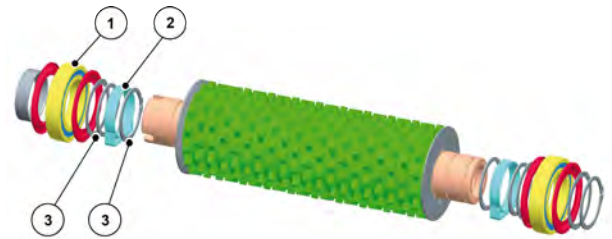

10.6 Checking and adjusting extended boom



The boom segments are preset at the factory to the correct position and the correct holding force. They only have to be readjusted after individual parts of the boom operating device and individual boom segments have been replaced.

Please contact our Service department before starting the adjustment operation.

- The boom segments must form one line **both in the vertical as well as in the horizontal orientation** after the individual segments have been folded out.
- At the same time, the sealing funnels must make close contact with the joint bearings of the boom elements.

Vertical adjustment

- ▶ Readjust the stop screws.

Horizontal adjustment

- ▶ Adjust the adjustment screws on the lower and upper bearing plate of the links.

WARNING!

Danger of crushing and shearing when boom segments are folded out

Limbs can be crushed or sheared off between the pendulum frame and the boom as well as at the link points of the boom.

- ▶ Never reach between the pendulum frame and the boom or between the boom elements.
- ▶ Wear protective gloves while carrying out checking and adjustment work.

WARNING!

Risk of injury due to swinging boom

When the pendulum frame locking mechanisms are open, the boom segments can swing severely and persons can be injured.

- ▶ Always close the pendulum frame locking mechanism while carrying out adjustment work.
- ▶ Ensure that nobody is present in the hazard zone of the boom.

Requirements:

- All boom segments are folded out all the way.
- The pendulum frame locking mechanism is closed.

■ *Boom segments: Vertical orientation*

Check

- The boom segments form one line in the vertical orientation.
- The sealing funnels are making close contact with the joint bearings of the boom elements.
- Distance A is approx. 47 mm.

- ▶ Check which boom segment is not oriented correctly.
- ▶ Release the lock nut [1] on the stop screw to be adjusted.
- ▶ Adjust the stop screws [2] at the respective link points.

Distance A should be approx. 47 mm in each case at the top, in the middle, and at the bottom.

- ▷ The boom segments must form one vertical line.
 - ▷ The sealing funnels must make close contact.
 - ▷ Distance A should be approx. 47 mm in each case at the top, in the middle, and at the bottom.
- ▶ Tighten the lock nut again.

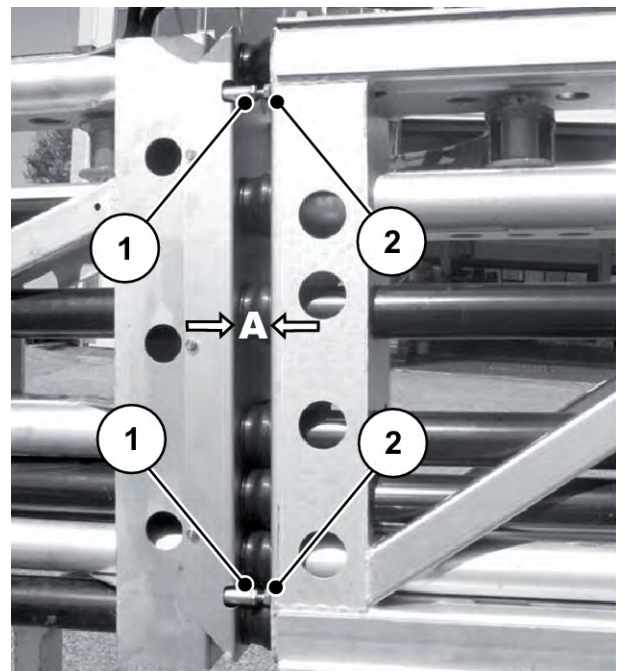

Fig. 57: Adjusting folded-out boom segments vertically

■ **Boom segments: Horizontal orientation**

Check

- The boom segments form one line in the horizontal orientation.
- The sealing funnels are making close contact with the joint bearings of the boom elements.

- ▶ Loosen the screws on the joint plate [3] (not completely).
- ▶ Loosen the nuts on the threaded rods [4] depending on the installation situation.
- ▶ Screw the threaded rods in or out to optimize the position.
 - ▷ The boom segments must form one horizontal line that gradually slopes towards the outside.
 - ▷ The sealing funnels must make close contact.
- ▶ Tighten the lock nut and the screws of the joint plate again.
- ▶ Generously grease the threaded rods with silver grease (graphite grease).

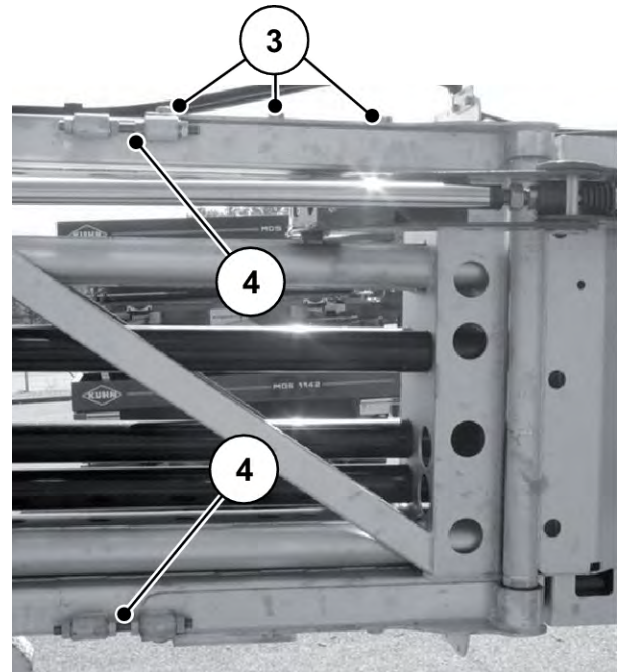

Fig. 58: Adjusting folded-out boom segments horizontally



Check during all adjustments whether the threaded rod is free of dirt.

After the horizontal adjustment, check the correct vertical adjustment again.

10.7 Adjusting the holding force of the boom segments

■ Holding force of the boom segments



Note:

- **Increase** tension: Screw out the threaded rod.
- **Reduce** tension: Screw in the threaded rod.



During the activities listed below, the hydraulic cylinders are always counted from the inside to the outside.

Example: The 2nd hydraulic cylinder, boom central section to the start section” is the 2nd cylinder from the inside.

The holding force of the boom central section to the start section is determined by the Belleville spring package on the 2nd hydraulic cylinder (extended state).

Boom central section to start section

- ▶ Release the lock nut [1].
- ▶ Adjust dimension X by turning the threaded rod [2] on the 2nd hydraulic cylinder.
 - ▷ Dimension X min. **60 mm**

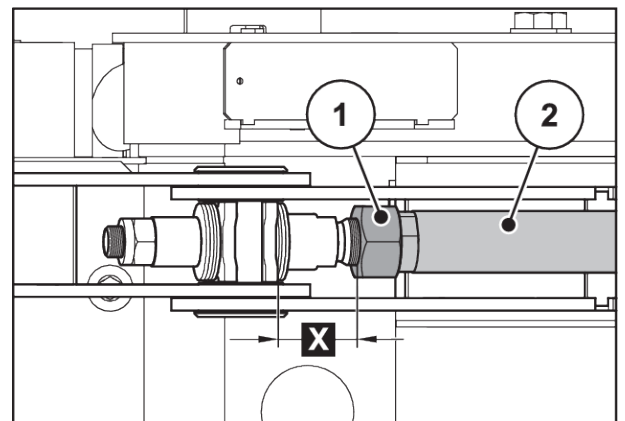

Fig. 59: Changing the holding force on the 2nd hydraulic cylinder

The holding force of the boom outer section is determined by the Belleville spring package on the 3rd hydraulic cylinder (extended state).

Boom end section

- ▶ Release the lock nut [1].
- ▶ Turn the threaded rod [2] on the 3rd hydraulic cylinder.
 - ▷ Gap size of the disc spring min. **1 mm**

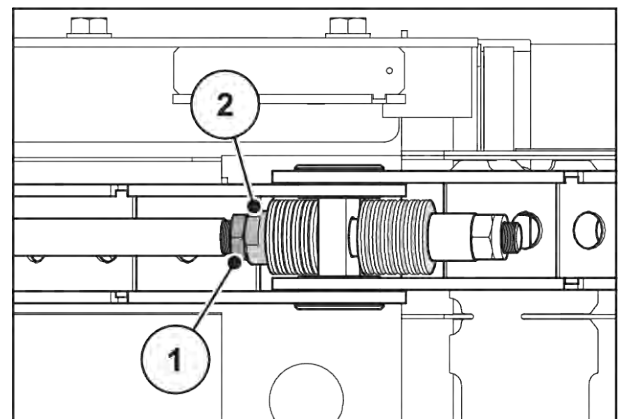

Fig. 60: Changing the holding force on the 2nd hydraulic cylinder

10.8 Checking and adjusting the folded in boom

■ Holding force of the boom segments

Checking position

- ▶ Slowly fold in the boom. While doing so, pay attention to the height (too high or too low) at which the booms are meeting the console.
- ▶ Wait until the boom locking mechanism is closed completely.
 - ▷ The tension of the folded-in boom package is maintained through the function of the locking blocks.
- ▶ Check the position of the boom packages.

- The transport lock [1] secures the boom on both sides to prevent it from folding out and fixes it in place in the transport position.
- The boom packages [2] are making contact with the side of the stop [3] with slight tension.
- The boom package are resting on the side consoles [4].

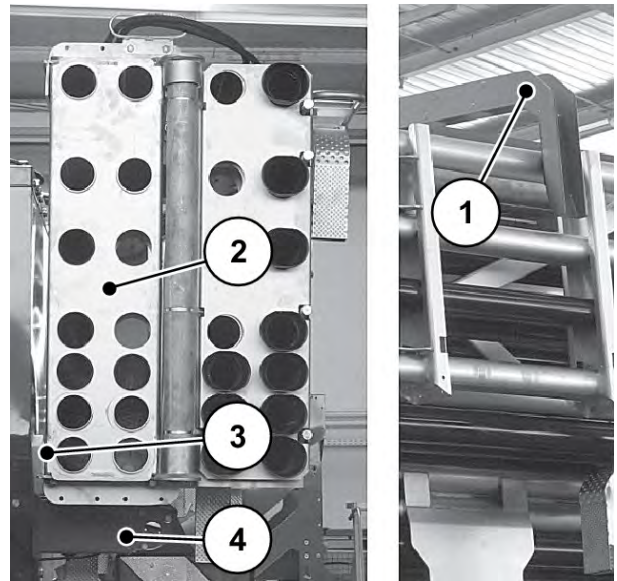

Fig. 61: Checking the folded-in boom

Adjusting holding tension on boom start section

- ▶ **Fold out the boom.** See 8.4 *Folding out the boom*
- ▶ Release lock nut [1].
- ▶ Remove the pin [3] and swivel out the cylinder.
- ▶ Turn the joint eye [2] on the 1st hydraulic cylinder on the start section.

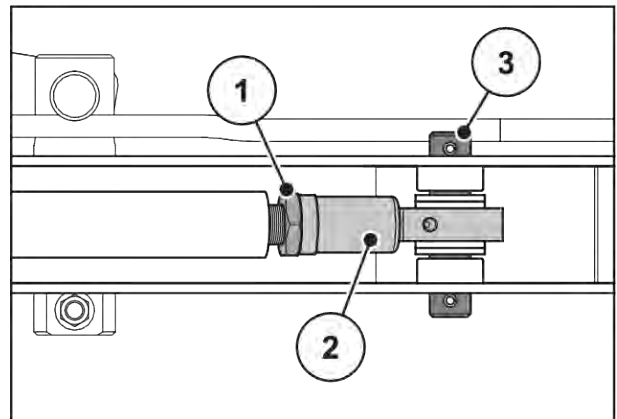

Fig. 62: Boom start section

Adjusting the holding tension on the boom central section

- ✓ The boom is folded in.
- ▶ Turn the nut [4] on the 2nd hydraulic cylinder.

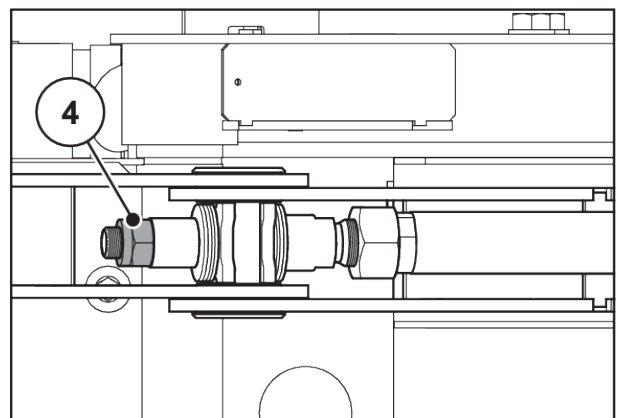

Fig. 63: Boom central section



Observe:

- **Increase** tension: Screw out threaded rod.
- **Reduce** tension: Screw in threaded rod.

Adjusting the holding tension on the boom end section

- ✓ The boom is folded in.
- ▶ Turn the nut [5] on the 3rd hydraulic cylinder.

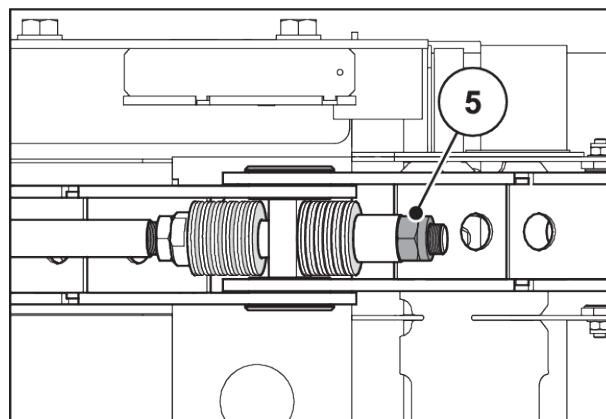

Fig. 64: Boom end section

10.9 Electrics, electronic system

■ Electric fuses

The power supply of the machine is fuse-protected via the ISOBUS cable of the tractor.

The ISOBUS cable features a **50 ampere** and a **30 ampere** fuse for overload protection. The fuses can be found in the electrical cabinet on the left side of the machine (viewed in the direction of travel).

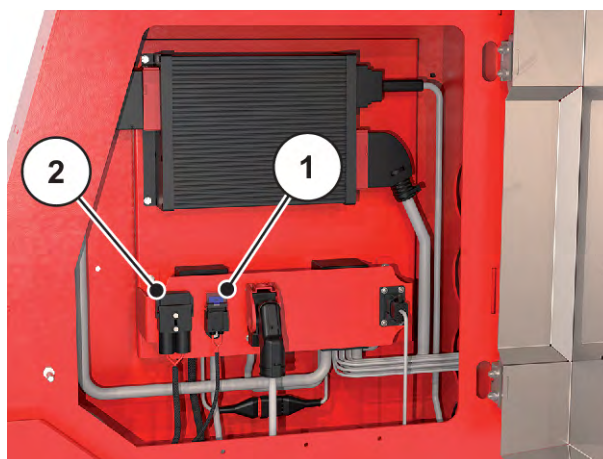

Fig. 65: Fuses at the ISOBUS cable

[1] 30 A fuse

[2] 50 A fuse

■ Electric lines

- ▶ Visually inspect all electric lines for wear.
 - ▷ Check particularly for outside damage or breaks.

■ **Lighting equipment**

- ▶ Check that the lighting equipment is in perfect condition every day.
- ▶ Replace damaged parts immediately.
- ▶ Clean dirty parts immediately.

■ **Electronic control unit**

 **WARNING!**

Risk of injury

The electronic control unit is checked in real time. This means, the selected function is directly executed by the machine components.

- ▶ Ensure that there is no-one present in the hazard zone.

Check the following functions of the electronic control unit:

- Check the forward speed sensor
- Check the filling level sensors
- Metering shaft speed



Check the function of the sensors and actuators with the AERO ISOBUS electronic machine control unit.

- Observe the operator's manual of the AERO ISOBUS electronic machine control unit.

■ **Checking the metering shaft speed**

- ▶ Check the gap size between the magnet and the encoder [1].

There are a total of 6 encoders on the machine. They are always placed directly on the metering drive.

- ▶ In case of faults, please follow the instructions in chapter 9 *Faults and possible causes*.

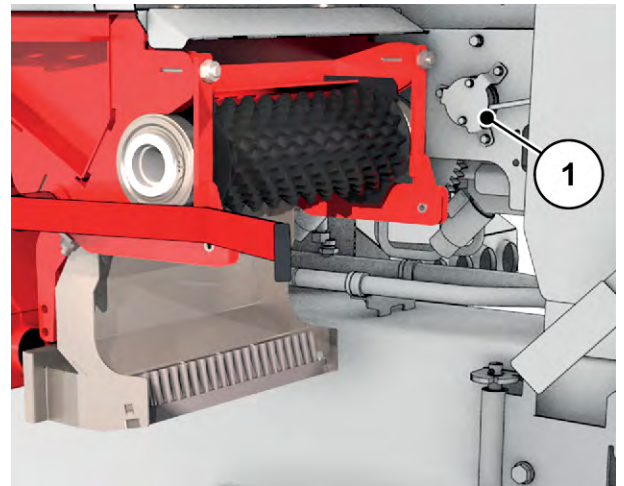

Fig. 66: Right metering

■ **Checking the forward speed sensor**

During transport and spreading, the current driving speed is displayed on the operating screen of the machine control unit.

- ▶ If this is not the case, check the driving speed sensor or the calibration.

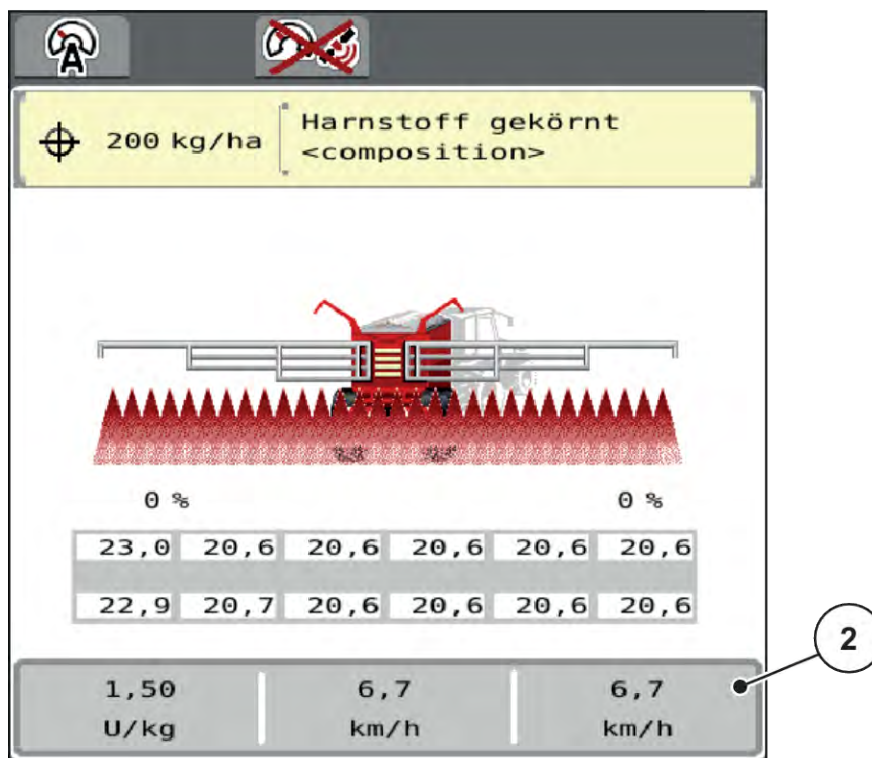

Fig. 67: Operating screen

- [2] Display of current driving speed

The forward speed sensor is installed in the axle hub on the left in the direction of travel [3].

- ▶ To check the installation position and the sensor distance, remove the protective sheet [4].

The distance between the wheel sensor and the pulse wheel must be 3 mm.

- ▶ Check the distance with a 3 mm thick metal strip and adjust it, if necessary.

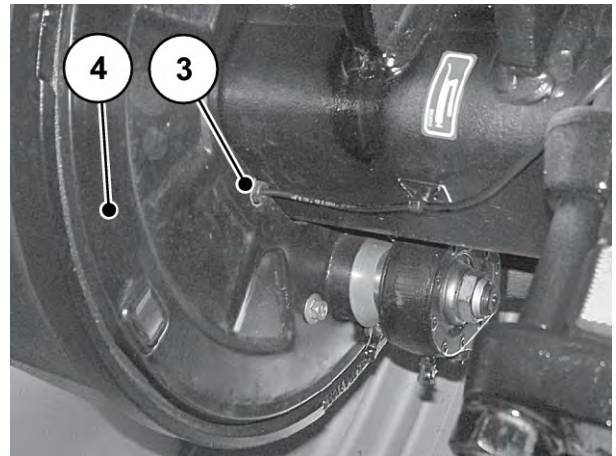

Fig. 68: Left wheel hub

■ **Checking temperature sensor and cooler**

Starting at an oil temperature of 62 °C, the oil cooler is switched on automatically. When the oil temperature drops below 62 °C, the oil cooler is switched off.

- [1] Temperature sensor
- [2] Oil cooler

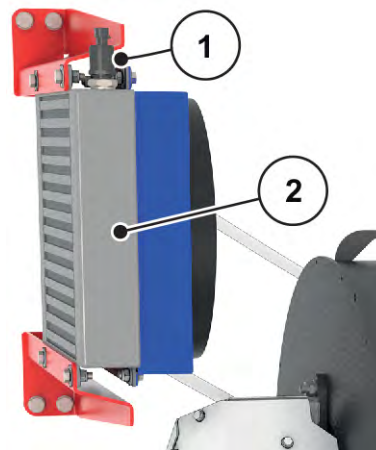

Fig. 69: Temperature sensor on oil cooler

- ▶ Access the menu System / Test > Test/diagnosis > Oil tank.
- ▶ Select the line and set the value to 121.
The temperature is shown on the terminal display.
If the value increases while the blower drive is running, the sensor is OK.
- ▶ Next, set the value back to the oil temperature alarm of 95 °C to ensure that the alarm message is displayed in case of overheating at the terminal.

10.10 Hydraulics system

The hydraulic system of the towed machine consists of two independent hydraulic circuits.

- Vario drive for the blower function with its own oil reservoir
- Hydraulic block with oil supply from the tractor

Within the hydraulic circuits, the drive components and actuators are connected with each other via hydraulic lines.

In the operating mode, the hydraulic system of the machine is subject to high pressure. In the operating mode, the temperature of the oil in the system is approx. 90°C.

! WARNING!

Danger due to high pressure and high temperature in the hydraulic system

Hot fluid escaping under high pressure may cause serious injury.

- ▶ Depressurize the hydraulic system before carrying out any work.
- ▶ Switch off the tractor engine and secure it against restarting.
- ▶ Let the hydraulic system cool down.
- ▶ When checking for leakage, wear protective goggles and protective gloves at all times.

! WARNING!

Danger of infection due to hydraulic oil

Hydraulic oil escaping under high pressure may penetrate the skin and cause infection.

- ▶ In the event of injury caused by hydraulic oil, seek medical attention immediately!

! WARNING!

Environmental pollution due to unsuitable disposal of hydraulic and transmission oil

The hydraulic and transmission oils are not entirely biodegradable. Therefore, oil must be prevented from entering the environment in an uncontrolled manner.

- ▶ Collect/dam escaped oil with sand, soil, or other absorptive material.
- ▶ Collect hydraulic and transmission oil in a suitable container provided for the purpose, and dispose of it in accordance with the local statutory requirements.
- ▶ Draining and penetration of oil into the sewerage system is to be prevented.
- ▶ Prevent the penetration of oil into the water drain by setting up sand or earth barriers, or by using other appropriate barrier methods.

10.10.1 Checking the hydraulic hoses

■ **Hydraulic hoses**

Hydraulic hoses are subject to high loads. They have to be checked regularly and are to be replaced immediately when damaged.

- ▶ Check the hydraulic hoses for damage on a regular basis or at least before the start of the spreading season, by means of a visual inspection.
- ▶ Before the start of the spreading season, check the age of the hydraulic hoses. Replace the hydraulic hoses when the prescribed period for storage and usage has been exceeded.
- ▶ Replace the hydraulic hoses if they show one or several of the following types of damage:
 - ▷ Damages to the external layer up to the insert
 - ▷ Embrittlement of the external layer (crack formation)
 - ▷ Deformation of the hose
 - ▷ Hose moving out of the hose fitting
 - ▷ Damages to the hose fitting
 - ▷ Resistance and function of the hose fitting reduced due to corrosion

10.10.2 Replacing hydraulic hoses

■ *Hydraulic hoses*

Hydraulic hoses are subject to aging. They may only be used for a maximum of 6 years, including a storage period of a maximum of 2 years.



The manufacturing date of a hose line is indicated in one of the hose fittings as year/month (e.g., 2012/04).

Preparation

- ▶ Ensure that the hydraulic system is depressurized and has cooled down.
- ▶ Provide collection trays for leaking hydraulic oil below the separation points.
- ▶ Have suitable plugs ready in order to prevent a leaking of the hydraulic oil out of the lines which cannot be replaced.
- ▶ Provide suitable tools.
- ▶ Put on your protective gloves and glasses.
- ▶ Ensure that the new hydraulic hose corresponds to the type of hydraulic hose to be replaced. In particular, observe the correct pressure range and hose length.

There are two nitrogen tanks in the hydraulic circuit. These also remain under pressure after system shutdown.

- ▶ Slowly and carefully open the screw connections of the hydraulic circuit.



Observe the different maximum pressure specifications on the hydraulic lines to be replaced.

Implementation:

- ▶ Loosen the hose fitting at the end of the hydraulic hose to be replaced.
- ▶ Discharge the oil from the hydraulic hose.
- ▶ Loosen the other end of the hydraulic hose.
- ▶ Put the loose hose end into the oil collection tray immediately and plug the connection.
- ▶ Loosen the hose fixtures and remove the hydraulic hose.
- ▶ Connect the new hydraulic hose. Tighten the hose fittings.
- ▶ Fix the hydraulic hose by means of the hose fixtures.
- ▶ Check the position of the new hydraulic hose.
 - ▷ The hose routing must correspond to the one of the old hydraulic hose.
 - ▷ Friction points are to be excluded.
 - ▷ The hose may not be twisted or tensioned.

The hydraulic hoses have been replaced successfully.

10.10.3 Nitrogen tank

■ Nitrogen tank

DANGER!

Risk of explosion

In case of improper mounting and handling, the nitrogen tank can explode or burst and cause severe injuries or death.

- ▶ Only qualified personnel may perform work on the hydraulic and pneumatic connections of the nitrogen tank.
- ▶ Please observe the instructions in the operator's manual of the nitrogen tank.

WARNING!

Hot surface

The accumulator body may heat up. There is a risk of burning.

- ▶ Only qualified personnel may perform work on the hydraulic and pneumatic connections of the nitrogen tank.

There are maintenance-free nitrogen tanks [1] in the hydraulic circuit.

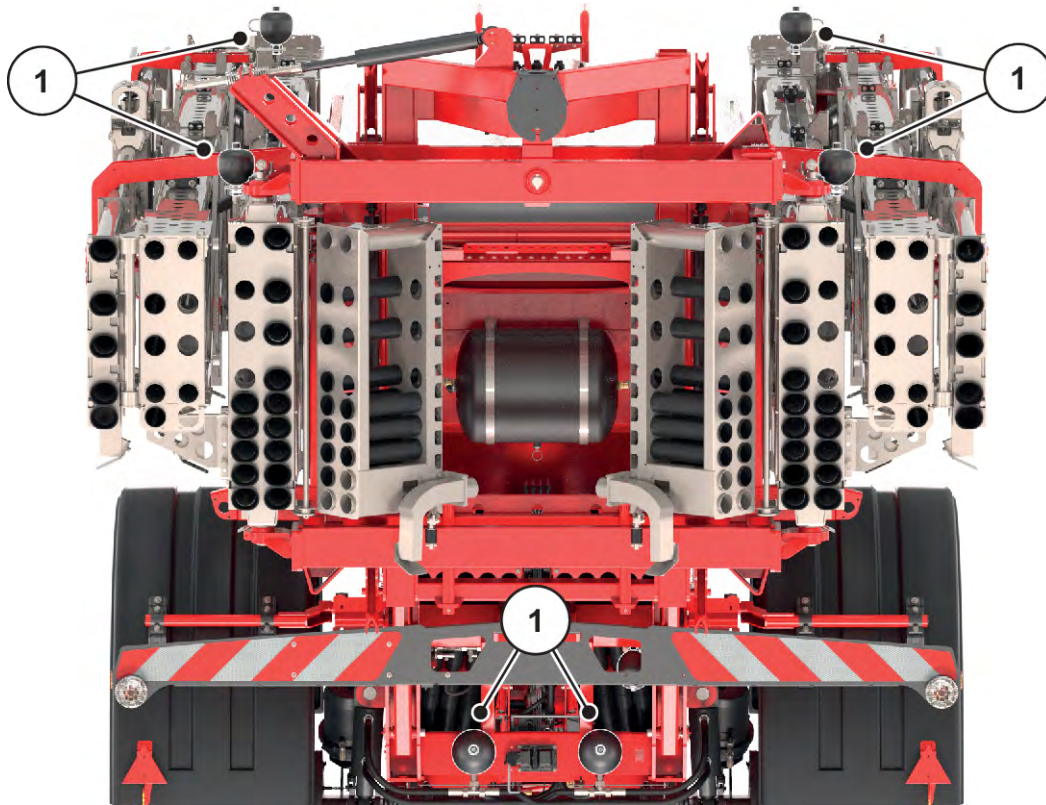

Fig. 70: Nitrogen tank

- ▶ Check the external condition of the nitrogen tank every 2 years at the latest.
- ▶ Prior to travel, check the nitrogen tank and all connections for damage.
- ▶ Check the mounting element for tight seating.

10.10.4 Hydraulic cylinders for adjustment functions

■ Hydraulic cylinders

- ▶ Regularly check the adjustment functions of all hydraulic cylinders and at least prior to every spreading operation.
- ▶ Check all components for external damage and leakage.

- [1] Hydraulic cylinders for boom height adjustment
- [2] Boom operating device
- [3] Pendulum frame locking mechanism
- [4] Hopper cover

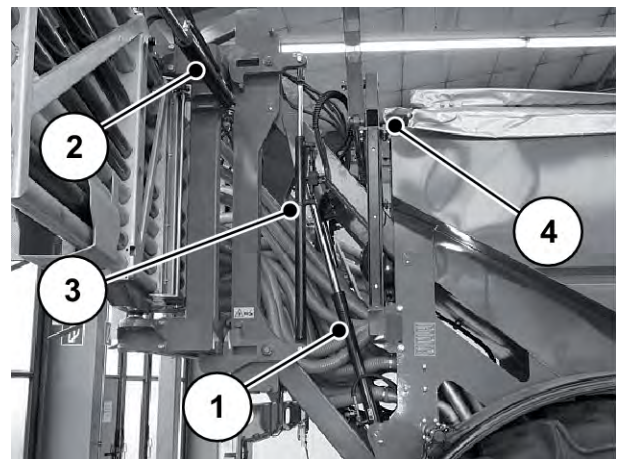

Fig. 71: Hydraulic cylinder, boom, right rear

- [[5]] Hydraulic cylinder for transport lock

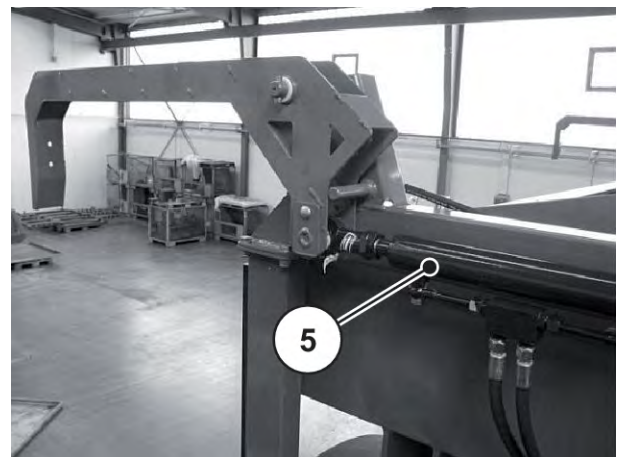

Fig. 72: Hydraulic cylinder, transport lock

- [[6]] Hydraulic cylinder for slope

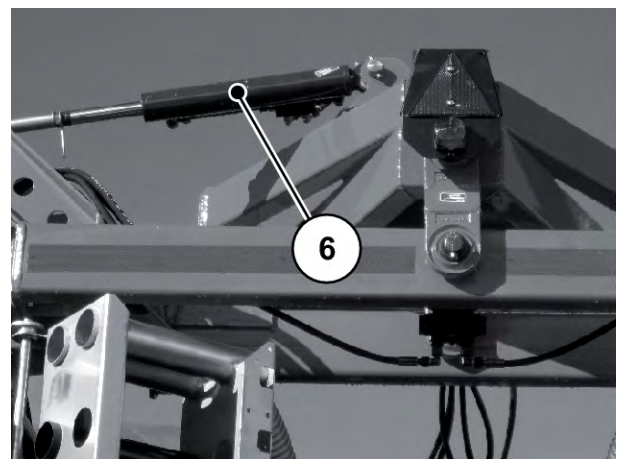

Fig. 73: Hydraulic cylinder, slope

10.10.5 Checking the hydraulic system of the Vario drive

The Vario drive is responsible for keeping the blower speed constant. The axial piston pump is driven by the tractor via the universal drive shaft. The oil reservoir of the on-board hydraulic system is filled with **approx. 40 liters** of hydraulic oil.

The Vario drive consists of the following components, which must be maintained:

- Universal drive shaft
- Transmission
- Axial piston pump
- Axial piston motor
- Oil reservoir
- Oil filter
- Oil cooler with temperature sensor

■ **Oil level**

- Read off the filling level on the filling level indication [1] of the oil reservoir [2].

The oil level is correct if it is between the green and red marking of the filling level indicator.

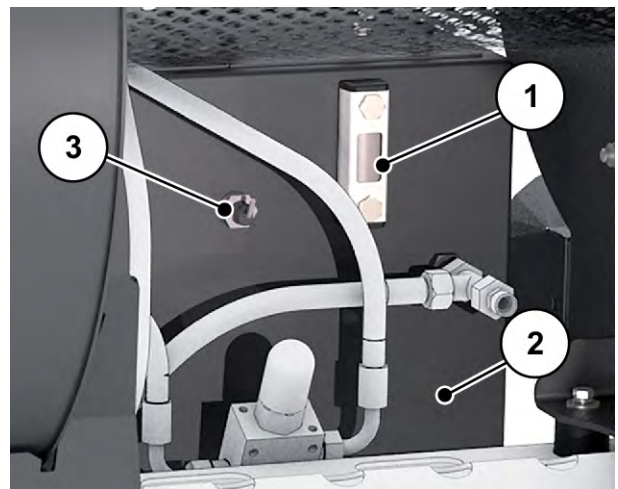

Fig. 74: Location of Vario drive oil reservoir



The oil reservoir is equipped with a filling level sensor [3]. The oil reservoir fill level can also be read in the machine control unit.

■ **Oil level in the transmission of the Vario drive**

- ▶ Open the checking screw [1] on the transmission.

The oil level is OK if oil runs out.

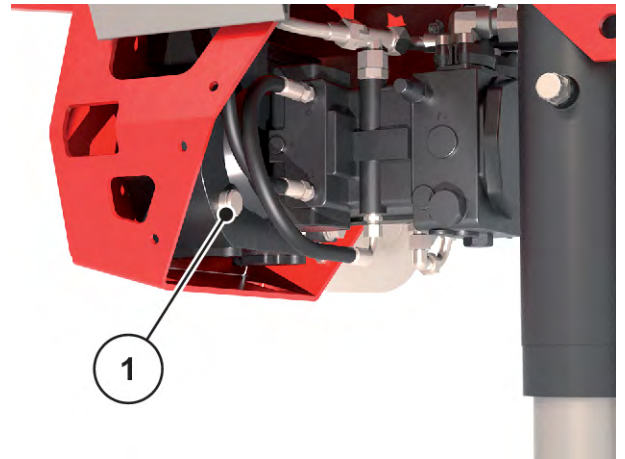

Fig. 75: Checking the oil level of the Vario drive transmission

- ▶ If the oil level is not OK, top up transmission oil.
- ▶ Find out what type of oil currently being used and top up the same type of transmission oil.

The oil level is OK if oil runs out of the checking screw.

10.10.6 Oil change and oil filter replacement

■ Vario drive

Component	Oil volume	Oil designation
On-board hydraulic system (Vario drive)	approx. 40 l	HVI 68 (HVLP 68 DIN 51524/ 3 ISO VG-68)



Always use **oil of the same grade, do not use biological oils.**

- ▶ Prior to draining the oil, position a sufficiently sized collection vessel (at least **45 l**) under the hopper.
- ▶ Detach the hydraulic hose [3] from the axial piston pump and let the oil flow into the collection vessel [4].
- ▶ Open the oil drain plug on the oil reservoir [1] and drain the residual oil into the collection vessel.
- ▶ Close the oil drain plug with a new sealing ring.
- ▶ Remove the oil filter [2].
- ▶ Drain the residual oil into the collection vessel.
- ▶ Fill the new oil filter with approx. 2 liters of oil.
- ▶ Screw on the new oil filter.
- ▶ Fasten the hydraulic hose [3] to the axial piston pump.

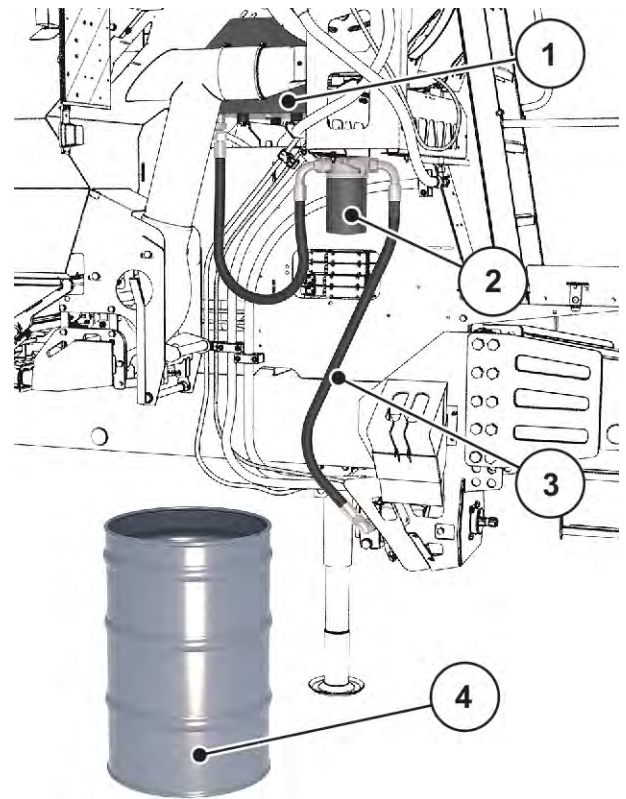

Fig. 76: Oil filter

The oil filter has been successfully replaced.

- ▶ Loosen the grating.
- ▶ Unscrew the cover of the filling opening.
- ▶ Fill new hydraulic oil into the oil reservoir [2].

The oil level is correct if it is between the green and red marking of the filling level indicator [1] (green corresponds to the maximum oil level).

- ▶ Close the filling screw.

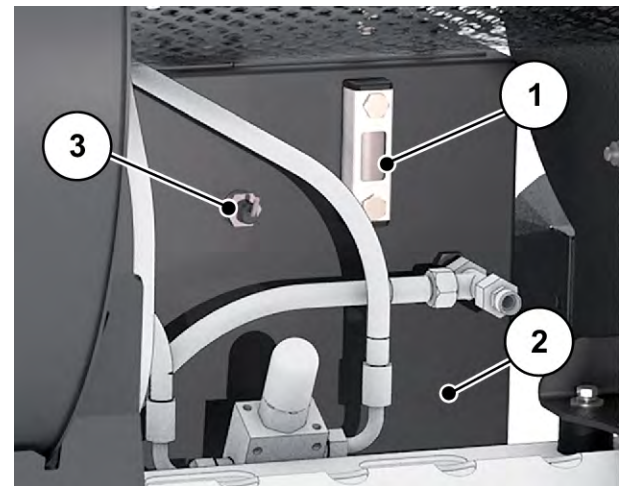

Fig. 77: Fill with oil

■ **Gearbox**

Component	Oil volume	Oil designation
Transmission (Vario drive)	Approx. 0.6 l	SAE 75W-90 transmission oil



Always use **oil of the same grade, do not use biological oils.**

- ▶ Place a sufficiently large collection vessel underneath.
- ▶ Open the oil drain plug on the oil reservoir [1].
The oil drains immediately.
- ▶ Drain the oil completely.
- ▶ Close the oil drain plug again.

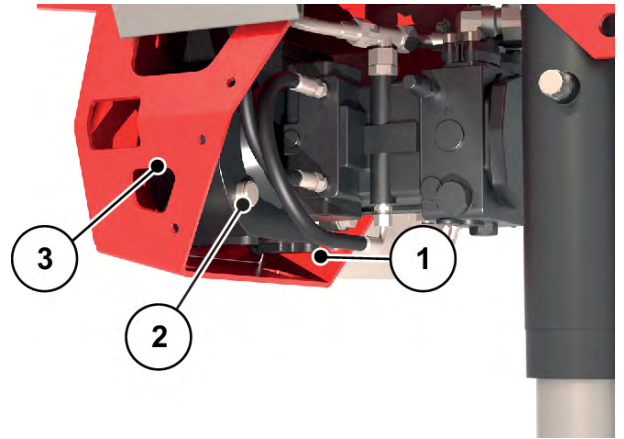

Fig. 78: Draining transmission oil

- ▶ Open the filling screw [2].
- ▶ Fill the transmission [3] with 0.6 liters of transmission oil.
- ▶ Close the filling screw [2] again.

The oil in the transmission of the Vario drive has been changed.



Carry out a test run:

- Let the blower drive run with a low PTO speed until the air in the system has been vented.
- Next, increase the speed to the maximum blower speed.

10.10.7 Checking other components

■ Hydraulic component

- ▶ Check axial piston pumps [1], axial piston motor [2], and oil chiller [3] on a regular basis.
- ▶ Check the hydraulic components for external damage and leakage.

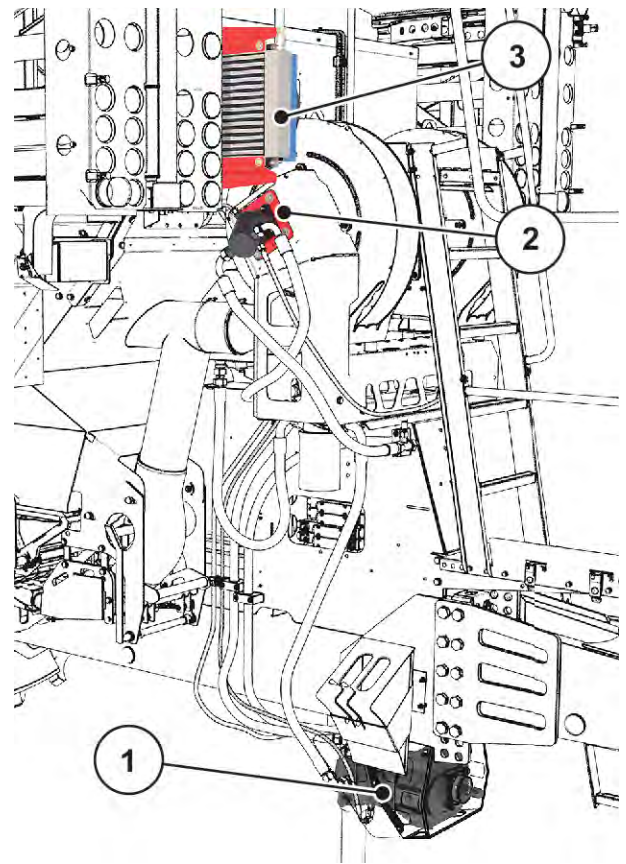

Fig. 79: Checking the axial piston pump, axial piston motor, and oil cooler

■ Hydraulic motors

The metering system is driven via three hydraulic motors on the left [1] and three hydraulic motors on the right.

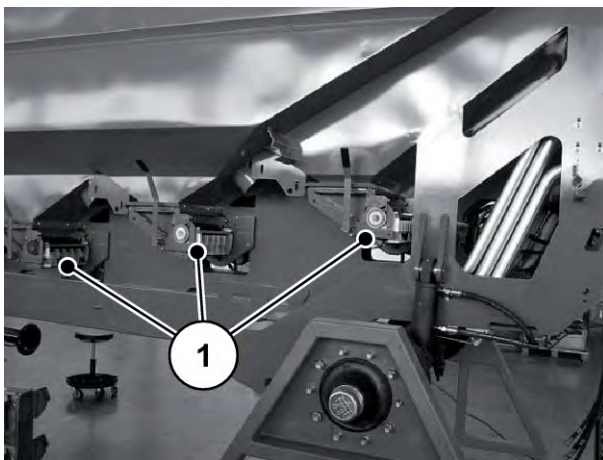

Fig. 80: Hydraulic motors on the left of the metering system

- ▶ Check the components for external damage and leakage.

10.11 Chassis and brakes

The machine is equipped with a two-circuit pneumatic braking system. Chassis and brakes are decisive for the operational safety of the machine.

WARNING!

Risk of accident due to improperly carried out work

Work improperly carried out at the chassis and the braking system compromises the operational safety of the machine and may lead to severe accidents with personal injury and property damage.

- ▶ Settings and repairs at the braking system may only be carried out by specialist workshops or approved brake repair services.

10.11.1 Checking the condition and function of the braking system

■ **Braking system**



The operator is personally responsible for ensuring that the system is in good condition.

Proper functioning of the braking system is essential for the safety of your machine.

Have the braking system checked by a specialist workshop at regular intervals, at least once a year.

- ▶ Regularly check the braking system for damage and leakage and at least prior to every travel.
- ▶ Check the braking system in a dry condition, **not when the vehicle is wet or during rain.**
- ▶ Check the brake lever and linkage for smooth operation.
- ▶ Replace the brake pad in time.
 - ▷ Only use the brake pads designated for the axles.

10.11.2 Checking the free travel of the slack adjuster

■ **Slack adjuster**

Checking the free travel

- ▶ Secure the machines against moving.
- ▶ Release the parking brake and the operating brake.
Push in both buttons [1] and [2].

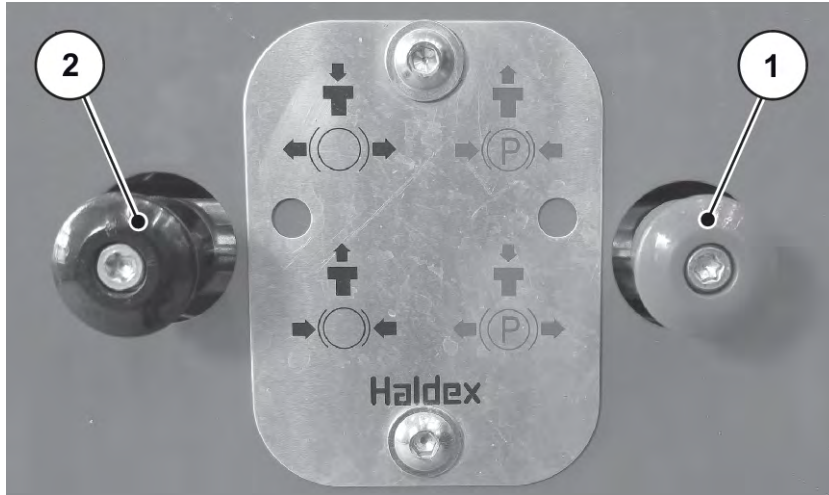

Fig. 81: Pneumatic brake

[1] Parking brake

[2] Operating brake

- ▶ Operate the slack adjuster by hand.

If the braking effect is reduced and the free travel exceeds 10 - 15% of the brake lever length [d], the specialist workshop must readjust the slack adjuster.

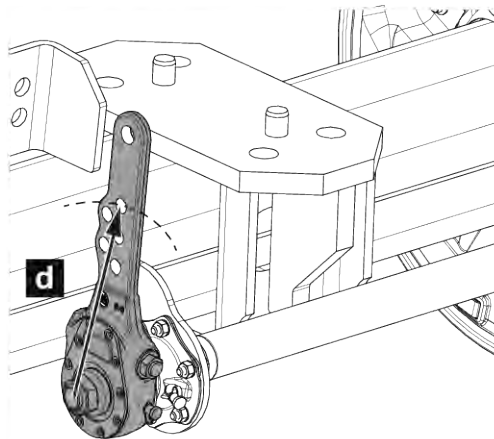

Fig. 82: Checking the free travel

[[d]] Brake lever length

Axle type	Brake lever length	Max. permissible free travel
BPW Rigid axle [1]	180 mm	27 mm



Only the specialist workshop is permitted to perform retrofitting work on the brakes.

10.11.3 Draining the air tank

■ *Air tank*

Condensation may occur in the pneumatic braking system of the brake circuit and accumulate in the air tank. To prevent corrosion-related damage to the pneumatic braking system, drain the air tank every day.

- ▶ Pull the operation pin [1] with a finger.
The tilt valve is opened.
- ▶ Fully drain the condensation water.
- ▶ Release the operation pin [1].

The air tank is drained.

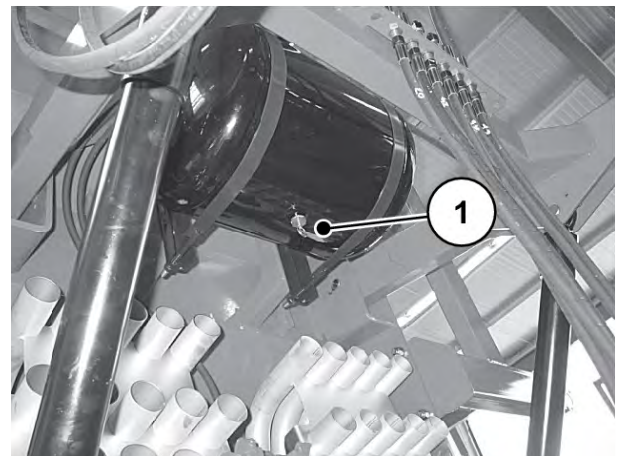

Fig. 83: Draining the air tank

10.11.4 Checking the brake pad

■ *Brake pad*

- ▶ Check the brake pad for wear.
- ▶ If necessary, renew the brake pads.

10.11.5 Checking the condition of the axle suspension

■ *Axle suspension*

- ▶ Check the axle suspension in dry condition.
- ▶ Check the suspension cylinders [2], diaphragm accumulators [1], and hydraulic lines [4] for damage.
- ▶ Visually check the block and the pressure compensator [3] for damage and leakage.

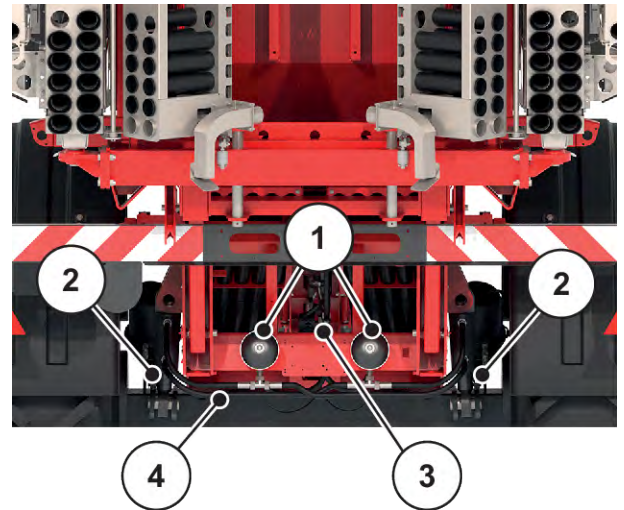

Fig. 84: Checking the axle suspension

- ▶ Check the suspension cylinder attachments such as pins [5] or lock screws [6] for tight seating.

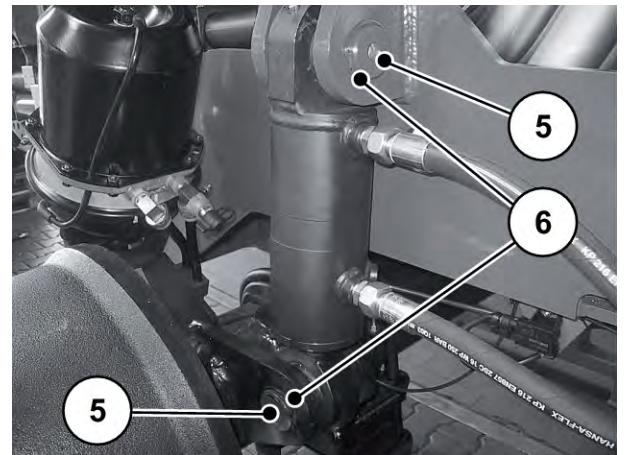

Fig. 85: Checking the suspension cylinder attachments

10.11.6 Checking the function of the axle suspension

■ Axle suspension

The hydropneumatic suspension is supplied by the tractor's hydraulic system and operated using the electronic control unit for the boom-type mineral fertilizer spreader.

Requirement:

- Make sure that the tractor's hydraulic system and the machine's electronic control unit are switched on.

Implementation

- ▶ Call up the Main menu > Hydr. axle suspension menu.





- ▶ Press the **Retract cylinder** function key until the hydraulic cylinders of the suspension are fully retracted.
- ▶ Press the **Extend cylinder** function key until the hydraulic cylinders of the suspension are fully extended and switched off.



- ▶ Press the **Automatic suspension** function key.
The hydraulic cylinders must now automatically move to the driving height (approx. 50 mm extended).
- ▶ Check the automatically adjusted driving height.

The function of the axle suspension has been checked.



If there are problems while checking the functions, please observe the manufacturer's instructions or contact our Service department.

Further information on the maintenance and service of the hydro-pneumatic suspension can also be found in the manufacturer's instructions.

10.12 Wheels and tires

The condition of the wheels and tires is crucial for the operational safety of the machine.

! WARNING!

Risk of accident due to improperly carried out work

Work improperly carried out at the wheels and tires compromises the operational safety of the machine and may lead to severe accidents with personal injury and property damage.

- ▶ Repairs at wheels and tires may only be carried out by **qualified personnel** with appropriate assembly tools.
- ▶ **Never** weld cracked rims or wheel disks. Due to the dynamic load during travel, the weld spots would break quickly.

10.12.1 Checking the tires

■ *Tires*

- ▶ Regularly check the tires for wear, damage, and foreign objects.
- ▶ Check the pressure of the cold tires in intervals of two weeks. Observe the manufacturer instructions.

10.12.2 Checking the condition of the wheels

■ *Wheels*

- ▶ Regularly check the wheels for deformation, corrosion, cracks and breaks.

Corrosions may lead to tension cracks at wheels and damage at tires.

- ▶ Keep the contact surface to the tire and the wheel hub free from corrosion.
- ▶ Immediately replace torn or deformed wheels or wheels that are damaged otherwise.
- ▶ Replace wheels with cracked or deformed bolt openings.

10.12.3 Checking the bearing clearance of the wheel hub

■ *Bearing clearance of the wheel hub*

- ▶ Check the bearing clearance of the wheel hub.

10.12.4 Changing wheels

The condition of the wheels and tires is crucial for the operational safety of the machine.

! WARNING!

Risk of accident due to improperly carried out change of wheels

Improper change of wheels at the machine may lead to severe accidents and personal injury.

- ▶ Change wheels only if the machine is empty and coupled to the tractor.
- ▶ For wheel change, the machine has to be parked on even and solid ground.

Requirements:

- Use a jack with a minimum load rating of **5 tons**.
- Use a torque wrench to tighten the wheel nuts.

Lifting jack positioning:

- The correct lifting jack application points are marked with an illustration.
- Position the lifting jack in such a way that the support surface cannot slip under any circumstances (e.g. by means of a fitting piece of wood or rubber block).



- ▶ Additionally secure the lifting chuck against slipping.
- ▶ For a wheel change on the right side in direction of travel, position the lifting jack on the right [1] under the axle attachment or directly on the axle - on the outside right.
- ▶ For a wheel change on the left side in direction of travel, position the lifting jack on the left [2] under the axle at the height of the spring link.

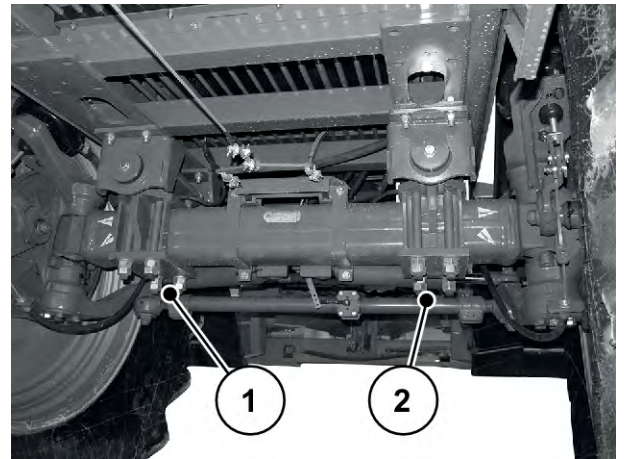

Fig. 86: Lifting jack application points

Fitting a wheel

- ▶ Prior to fitting, clean the contact face of the wheel at the hub.
- ▶ Prior to fitting, check the wheel nuts and bolts. Replace damaged, stuck or corroded wheel nuts or bolts.
- ▶ Tighten all wheel nuts in steps and across diagonals using a torque wrench.
 - ▷ Tighten the wheel nuts to a tightening torque of **510 Nm**.
 - ▷ Screw on all **10** wheel nuts per wheel and tighten them.

Due to settling, wheel nuts will become loosened during the first kilometers of travel of the new machine or after a wheel has been changed.

- ▶ After 50 km, retighten all wheel nuts to the specified tightening torque.



Follow the instructions and perform the tasks specified by the axle manufacturer for fitting a wheel.

10.13 Recovery of the machine

If the machine cannot be towed by the tractor, proceed as follows to recover the machine from the field.

- ▶ Attach a rope around the body of the axle.

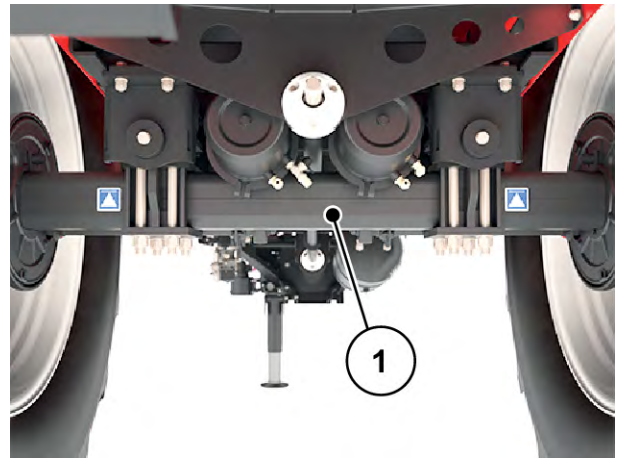

Fig. 87: Recover the machine with the rope

10.14 Lubrication

10.14.1 Drive shaft lubrication

■ *Universal drive shaft*

- Lubricant: Grease
- See operator's manual of the manufacturer.

10.14.2 Lubricating the pendulum frame

■ *Joints, bearings: Pendulum frame*

- Lubricant: Grease, oil

[[1]] Lubrication point, pendulum frame locking mechanism, top, left, and right

[[3]] Lubrication point, bearing eyes for boom on pendulum frame at top and bottom, left and right

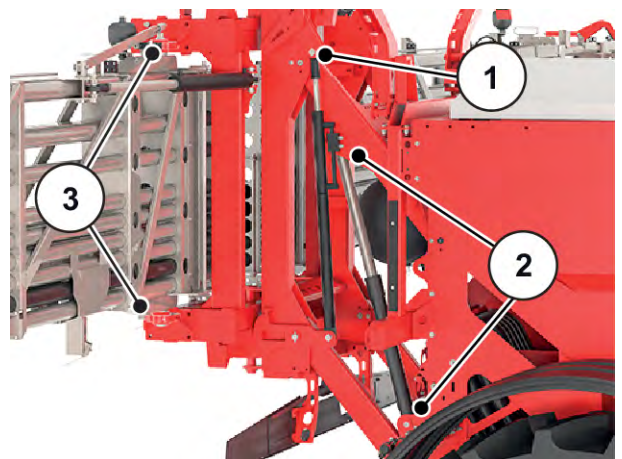

Fig. 88: Joint bearings on hydraulic cylinder for pendulum frame locking mechanism

- [1] Lubrication point, hydraulic cylinder for slope, left and right
- [2] Bearing eyes on pendulum frame, inside and outside

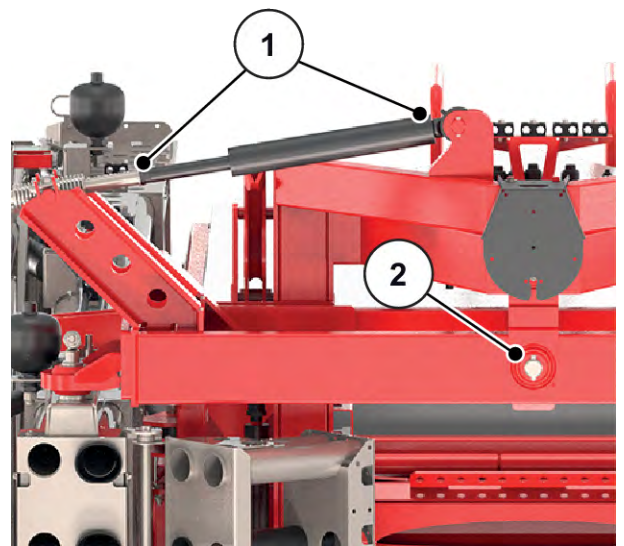

Fig. 89: Lubrication points, pendulum frame

- [1] Lubrication point

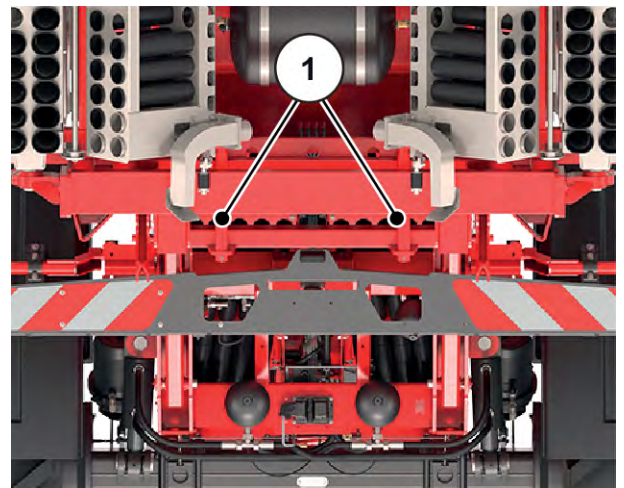

Fig. 90: Sliding surface between guide pin and pendulum frame

- [1] Lubrication point

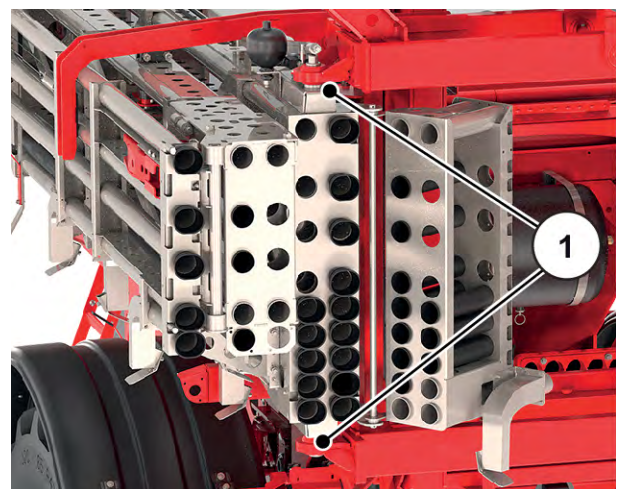

Fig. 91: Joint bearings for boom on pendulum frame

10.14.3 Lubricating the boom

■ *Joints, bearings: Boom*

- Lubricant: Grease, oil

[1] Lubrication point

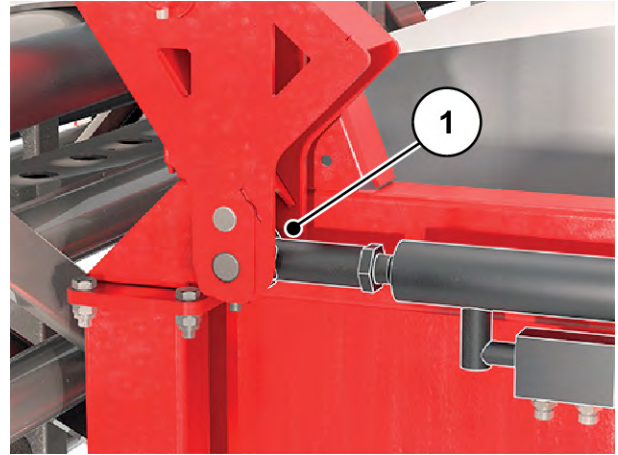

Fig. 92: Hydraulic cylinder for boom safety catch

[1] Lubrication point, joint eyes on hydraulic cylinder for boom start section, left and right

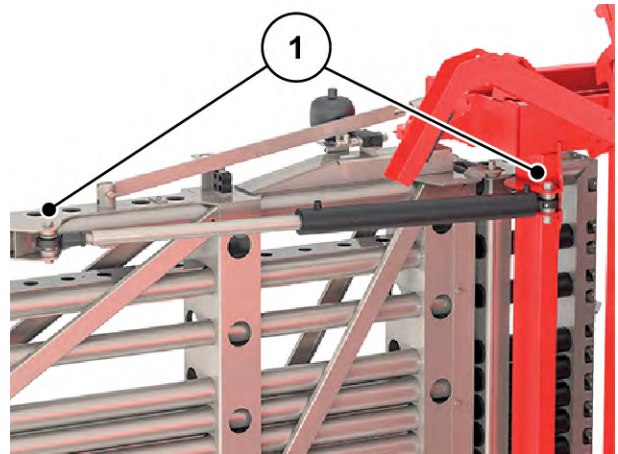

Fig. 93: Boom start section

- [1] Lubrication point, joint bearings system for boom central section, left and right
- [2] Lubrication point, disc spring assembly on hydraulic cylinder for boom central section, left and right

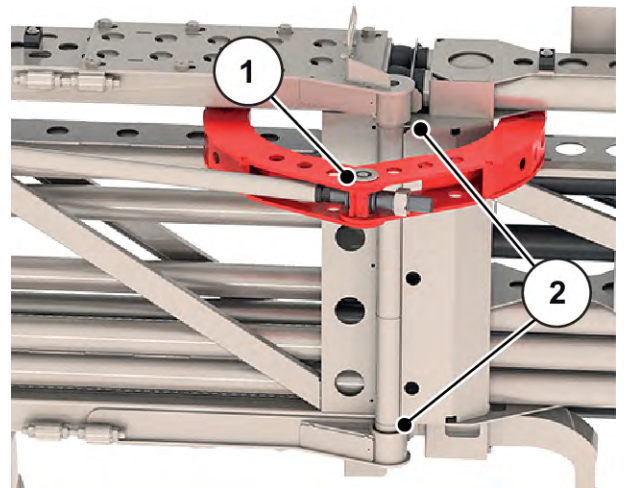

Fig. 94: Boom central section

- [1] Lubrication point, joint eyes on hydraulic cylinder for boom central section, left and right

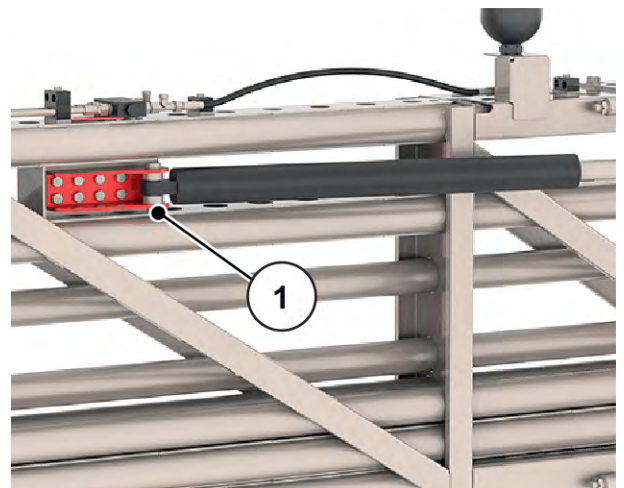

Fig. 95: Boom central section

- [1] Lubrication point, joint bearings system for boom end section, left and right
- [2] Lubrication point, joint eyes on hydraulic cylinder for boom end section, left and right
- [3] Lubrication point, disc spring assembly on hydraulic cylinder for boom end section, left and right

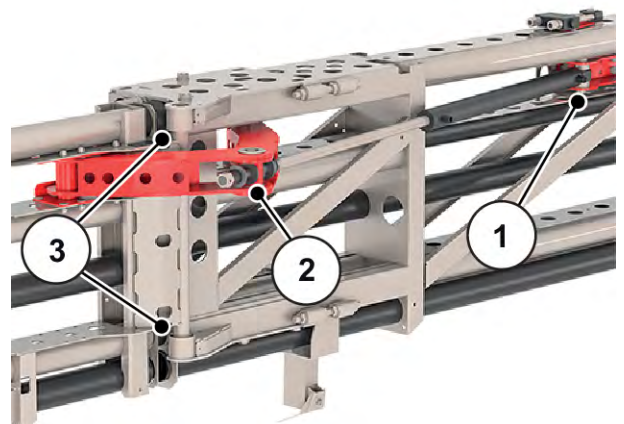

Fig. 96: Boom end section

10.14.4 Lubricating the parallelogram

- *Joints, bearings: Parallelogram*

- Lubricant: Grease, oil

[[2]] Lubrication point, parallelogram, top, bottom, left and right

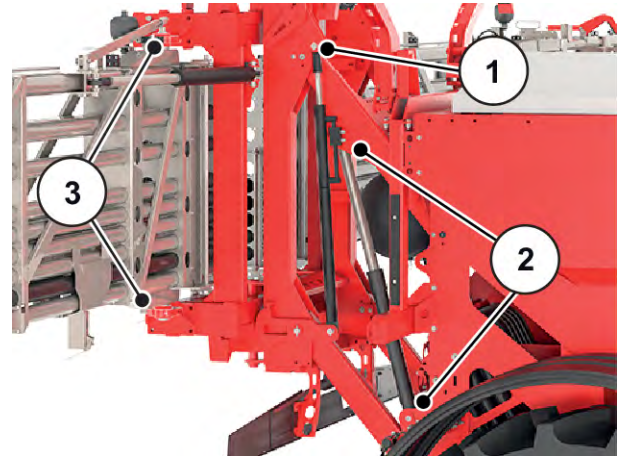

Fig. 97: Joint bearings on hydraulic cylinder for parallelogram

[1] Lubrication point

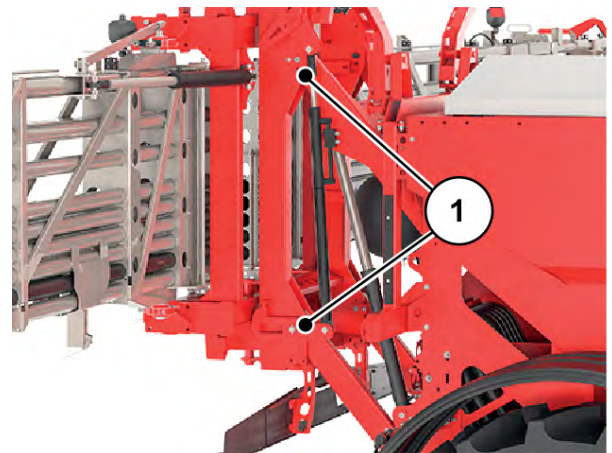

Fig. 98: Mounting frame bearing pin

[1] Lubrication point

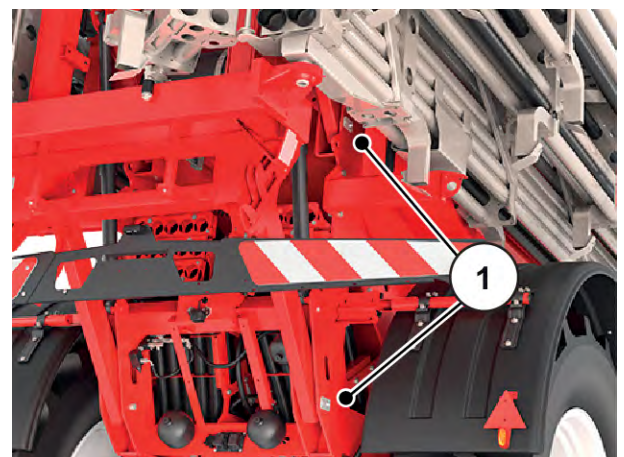

Fig. 99: Parallelogram bearing pin

10.14.5 Lubrication of links, bushes

■ *Joints, bushes*

- Lubricant: Grease, oil

10.14.6 Lubricating other components

■ *Joints, bearings: Other components*

- Lubricant: Grease, oil

[1] Lubrication point

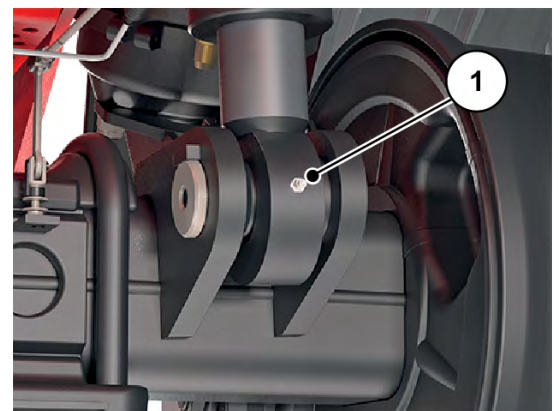

Fig. 100: Joint bearings on hydraulic cylinder for axle suspension

[1] Lubrication point

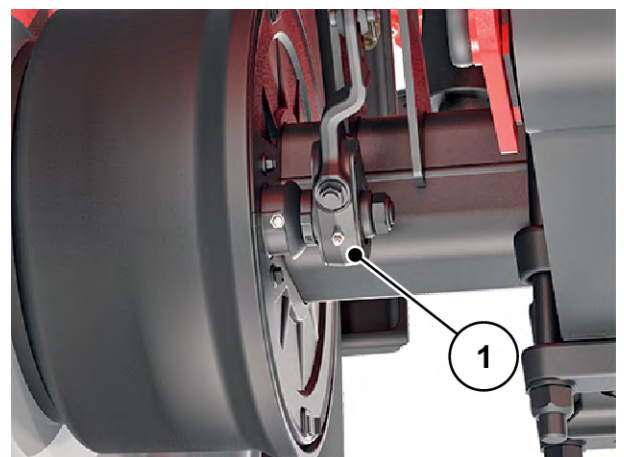

Fig. 101: Left brake lever bearing

Lubrication points of other components (not shown)

- Towing eye of coupling
- Coupling bracket of ball coupling

11 Winterization and preservation

11.1 Safety

NOTICE!

Environmental pollution due to unsuitable disposal of hydraulic and transmission oil

The hydraulic and transmission oils are not entirely biodegradable. Therefore, oil must be prevented from entering the environment in an uncontrolled manner.

- ▶ Collect/dam escaped oil with sand, soil, or other absorptive material.
- ▶ Collect hydraulic and transmission oil in a suitable container provided for the purpose, and dispose of it in accordance with the local statutory requirements.
- ▶ Draining and penetration of oil into the sewerage system is to be prevented.
- ▶ Prevent the penetration of oil into the water drain by setting up sand or earth barriers, or by using other appropriate barrier methods.

In combination with moisture, fertilizer can form aggressive acids that attack paints, plastics, and especially metal parts. This is why **regular washing and caring after use** is very important.



Prior to winterizing, thoroughly **wash** the machine (refer to *10.2 Cleaning the machine*) and let it dry well.

Next, **preserve** the machine (refer to *11.3 Preserving the machine*).

- ▶ Hang up hoses and cables (refer to *8.9 Parking and unhitching the machine*).
- ▶ Park the machine (refer to *8.9 Parking and unhitching the machine*).
- ▶ Close the hopper cover. Leave a gap open to prevent moisture in the hopper.
- ▶ If present, disconnect the control unit or the ISOBUS terminal from power and dust off.



Do not store the control unit or the ISOBUS terminal outdoors. Store in a suitable warm location.

- ▶ Place dust caps on hoses and cable.
- ▶ Open the fertilizer outlets:
 - ▷ Metering slide, pre-metering slide, drain door, etc (depends on the machine)

11.2 Washing the machine

A fertilizer spreader that is placed into storage **must** first be cleaned.

- ▶ Remove the dirt deflector (refer to 4.2.1 *Assembly overview*).
- ▶ Fold up the protective grid in the hopper (refer to 4.2.1 *Assembly overview*).
- ▶ When cleaning with high-pressure, never aim the water jet directly at warning signs, electrical equipment, hydraulic components, and sliding bearings.
- ▶ Let the machine dry after cleaning.



Do not store the terminal outdoors. Store in a suitable warm location.



Lubricating the machine before winterization (refer to 10.14 *Lubrication*)

11.3 Preserving the machine



- Only spray on **approved and environmentally friendly** preserving agents.
- Prevent mineral oil-based agents (diesel, etc.). They are rinsed off when the machine is first washed and can get into the sewage system.
- Only use preservation agents that will not attack the paint, plastics, and rubber seals.

- ▶ Only spray the machine once certain that it is completely **clean** and **dry**.
- ▶ Treat the machine with environmentally friendly anti-corrosion agents.
 - ▷ We recommend using protective wax or preservation wax.



Please contact your specialist dealer or your specialist workshop if you want to obtain preservation agents.

Preserve the following assemblies or parts:

- All hydraulic components that are susceptible to rust, e.g., hydraulic couplers, pipes, press-fit rings, and valves
- Galvanized bolts
- If present on your machine:
 - Parts of the braking system
 - Pneumatic lines
 - Spray galvanized **bolts on the axles and the drawbar** with a special protective wax after washing.



The video "Getting ready - winterization essentials" gives further useful information on washing and protection.

- Visit the RAUCH YouTube channel.
- Here is the link to the video: "*Winterization video*".

12 Disposal

12.1 Safety

NOTICE!

Environmental pollution due to unsuitable disposal of hydraulic and transmission oil

The hydraulic and transmission oils are not entirely biodegradable. Therefore, oil must be prevented from entering the environment in an uncontrolled manner.

- ▶ Collect/dam escaped oil with sand, soil, or other absorptive material.
- ▶ Collect hydraulic and transmission oil in a suitable container provided for the purpose, and dispose of it in accordance with the local statutory requirements.
- ▶ Draining and penetration of oil into the sewerage system is to be prevented.
- ▶ Prevent the penetration of oil into the water drain by setting up sand or earth barriers, or by using other appropriate barrier methods.

NOTICE!

Environmental pollution caused by inappropriate disposal of packaging materials

Packaging material contains chemical compounds, which must be dealt with appropriately.

- ▶ Packaging material is to be disposed of at an authorized waste management company.
- ▶ Observe the national regulations.
- ▶ Packaging material may not be burned nor disposed of with the domestic waste processing.

NOTICE!

Environmental pollution caused by inappropriate disposal of components

The inappropriate disposal of materials is a threat to the environment.

- ▶ Only authorized companies may be commissioned with disposal.

12.2 Disposal of the machine

The following points apply without restriction. Stipulate suitable precautionary measures based on the national legislation and implement them.

- ▶ All components, auxiliary and operating materials from the machine must be removed by specialist staff.
 - ▷ In so doing, these parts are to be sorted into specific categories.
- ▶ All waste products are then to be disposed of in accordance with local regulations and directives for recycling or special refuse categories by authorized companies.

13 Appendix

13.1 Tire table

Specification of permitted tire types and track widths according to EU type approval for AERO GT										
Tire combination No	Axle No	Calculation braking system	Tire dimension including load capacity index and speed category symbol	Rolling radius [mm]	Tire Load rating per tyre [kg]	Maximum permissible mass per axle [kg/(")]	Maximum permissible mass of the vehicle [kg/(")]	Maximum permissible vertical load on the coupling point [kg/(")]	Track width [mm]	
									Minimum	Maximum
1	1	1	IF 380/90 R46 164 A8	875	5000	10000	10000	-	2250	2600
2	1	1	VF 380/90 R 46 164 A8	875	5000	10000	10000	-	2250	2600
3	1	1	IF 380/105 R50 164 A8	1025	5000	10000	10000	-	2250	2600
4	1	1	VF 380/105 R 50 164 A8	975	5000	10000	10000	-	2250	2600
5	1	1	VF 420/95 R 50 164 A8	1000	5000	10000	10000	-	2250	2500
6	1	1	480/80 R 46 164 A8	925	5000	10000	10000	-	2250	2500
7	1	1	VF 480/80 R 46 164 A8	925	5000	10000	10000	-	2250	2500
8	1	1	480/80 R 50 164 A8	975	5000	10000	10000	-	2250	2500
9	1	1	IF 480/80 R50 164 A8	975	5000	10000	10000	-	2250	2500
10	1	1	VF 480/80 R 50 164 A8	975	5000	10000	10000	-	2250	2500
11	1	1	520/85 R 42 164 A8	925	5000	10000	10000	-	2250	2400
12	1	1	IF 520/85 R42 164 A8	925	5000	10000	10000	-	2250	2400
13	1	1	VF 520/85 R 42 164 A8	925	5000	10000	10000	-	2250	2400
14	1	1	520/85 R 46 164 A8	975	5000	10000	10000	-	2250	2400
15	1	1	VF 520/85 R 46 164 A8	975	5000	10000	10000	-	2250	2400
16	1	1	580/85 R 42 164 A8	975	5000	10000	10000	-	2250	2400
17	1	1	IF 580/85 R 42 164 A8	975	5000	10000	10000	-	2250	2400
18	1	1	VF 580/85 R 42 164 A8	975	5000	10000	10000	-	2250	2400
19	1	1	650/65 R 42 164 A8	925	5000	10000	10000	-	2250	2300
20	1	1	VF 650/65 R 42 164 A8	925	5000	10000	10000	-	2250	2300
21	1	1	650/85 R 38 164 A8	975	5000	10000	10000	-	2250	2300
22	1	1	IF 650/85 R38 164 A8	975	5000	10000	10000	-	2250	2300
23	1	1	VF 650/85 R 38 164 A8	975	5000	10000	10000	-	2250	2300
24	1	1	710/70 R 42 164 A8	975	5000	10000	10000	-	2250	2250
25	1	1	IF 710/70 R42 164 A8	975	5000	10000	10000	-	2250	2250
26	1	1	VF 710/70 R 42 164 A8	975	5000	10000	10000	-	2250	2250



(*) According to the tyre specification

1. Calculation braking system for brake cylinder from Haldex

13.2 Torque value

Tightening torque and assembly pre-load for bolts with metric thread and standard or fine pitch



The values listed apply to dry or slightly lubricated connections.
 Do not use galvanized (plated) bolts and nuts without grease.
 When using a stiff grease, reduce the value in the table with 10%.
 When using (self-)locking bolts and nuts increase the value in the table with 10%.

Tightening torque and assembly pre-load with $v=0,9$ for shank bolts with metric thread and standard or fine pitch according to ISO 262 and ISO 965-2

Steel class quality fasteners according to ISO 898-1

Head dimensions of hexagonal bolts according to ISO 4014 to ISO 4018

Head dimensions of cylindrical bolts according to ISO 4762

Hole "medium" according to EN 20273

Friction coefficient: $0,12 \leq \mu \leq 0,18$

Metric thread with standard pitch				
Thread	Class	Tightening torque		Max. assembly pre-load ($\mu_{\min}=0.12$) N
		N.m	(lbf.in) lbf.ft	
M4 (X0.7)	8.8	3	(26.5)	4400
	10.9	4.9	(40.7)	6500
	12.9	5.1	(45.1)	7600
M5 (X0.8)	8.8	5.9	(52.2)	7200
	10.9	8.6	(76.1)	10600
	12.9	10	(88.5)	12400
M6 (X1)	8.8	10.1	7.4	10200
	10.9	14.9	11	14900
	12.9	17.4	12.8	17500
M8 (X1.25)	8.8	24.6	18.1	18600
	10.9	36.1	26.6	27300
	12.9	42.2	31.1	32000

Metric thread with standard pitch				
Thread	Class	Tightening torque		Max. assembly pre-load ($\mu_{\min}=0.12$) N
		N.m	(lbf.in) lbf.ft	
M10 (X1.5)	8.8	48	35.4	29600
	10.9	71	52.4	43400
	12.9	83	61.2	50800
M12 (X1.75)	8.8	84	62	43000
	10.9	123	90.7	63200
	12.9	144	106.2	74000
M14 (X2)	8.8	133	98	59100
	10.9	195	143.8	86700
	12.9	229	168.9	101500
M16 (X2)	8.8	206	151.9	80900
	10.9	302	222.7	118800
	12.9	354	261	139000
M18 (X2.5)	8.8	295	217.6	102000
	10.9	421	310.5	145000
	12.9	492	363	170000
M20 (X2.5)	8.8	415	306	130000
	10.9	592	436.6	186000
	12.9	692	510.4	217000
M22 (X2.5)	8.8	567	418.2	162000
	10.9	807	595	231000
	12.9	945	697	271000
M24 (X3)	8.8	714	526.6	188000
	10.9	1017	750.1	267000
	12.9	1190	877.1	313000
M27 (X3)	8.8	1050	774.4	246000
	10.9	1496	1013.3	351000
	12.9	1750	1290.7	410000

Metric thread with standard pitch				
Thread	Class	Tightening torque		Max. assembly pre-load ($\mu_{\min}=0.12$) N
		N.m	(lbf.in) lbf.ft	
M30 (X3.5)	8.8	1428	1053.2	300000
	10.9	2033	1499.4	427000
	12.9	2380	1755.4	499000
M36 (X4)	8.8	2482	1830.6	438000
	10.9	3535	2607.3	623000
	12.9	4136	3050.5	729000

Metric thread with fine pitch				
Thread	Class	Tightening torque		Max. assembly pre-load ($\mu_{\min}=0.12$) N
		N.m	lbf.ft	
M8X1	8.8	26.1	19.2	20200
	10.9	38.3	28.2	29700
	12.9	44.9	33.1	34700
M10X1.25	8.8	51	37.6	31600
	10.9	75	55.3	46400
	12.9	87	64.2	54300
M12X1.25	8.8	90	66.4	48000
	10.9	133	98	70500
	12.9	155	114.3	82500
M12X1.5	8.8	87	64.2	45500
	10.9	128	94.4	66800
	12.9	150	110.6	78200
M14X1.5	8.8	142	104.7	64800
	10.9	209	154.1	95200
	12.9	244	180	111400

Metric thread with fine pitch				
Thread	Class	Tightening torque		Max. assembly pre-load ($\mu_{\min}=0.12$) N
		N.m	lbf.ft	
M16X1.5	8.8	218	160.8	87600
	10.9	320	236	128700
	12.9	374	275.8	150600
M18X1.5	8.8	327	241.2	117000
	10.9	465	343	167000
	12.9	544	401	196000
M20X1.5	8.8	454	335	148000
	10.9	646	476.5	211000
	12.9	756	557.6	246000
M22X1.5	8.8	613	452	182000
	10.9	873	644	259000
	12.9	1022	754	303000
M24X2	8.8	769	567	209000
	10.9	1095	807.6	297000
	12.9	1282	945.5	348000

14 Guarantee and warranty

RAUCH devices are manufactured using modern production methods and with the greatest of professional care, and are subjected to numerous inspections.

This is why RAUCH is offering a 12 month warranty if the following conditions are met:

- The warranty starts on the date of purchase.
- The warranty covers material or manufacturing defects. We are liable for third-party products (hydraulics, electronics) only to the extent of the relevant manufacturer. During the warranty period, manufacturing and material defects will be rectified free of charge with the replacement or repair of the affected parts. Other rights extending beyond the above, such as claims for conversion, reduction, or replacement for reasons of damage not suffered by the supplied product are explicitly excluded. Warranty services are provided by authorized workshops, by RAUCH factory representatives or the factory itself.
- Consequences of natural wear, dirt, corrosion, and all defects caused by improper use as well as external influences shall be excluded from the warranty. Any unauthorized repairs or changes to the original condition will void the warranty. The warranty is voided if any spare parts other than genuine RAUCH spare parts were used. Therefore, the directions in the operating manual must be observed. Please contact our company representatives of the parent company if you have any questions or doubts. Warranty claims must be submitted to the company within 30 days at the latest after the damage has occurred. The date of purchase and the machine number must be indicated. If repairs under the warranty are required, they must be carried out by the authorized workshop only after consultation with RAUCH or the company's appointed representatives. The warranty period will not be extended by warranty work. Transport damage is not a factory defect and is therefore not covered by the manufacturer's warranty manufacturer.
- Claims for damage other than to the RAUCH devices will not be accepted. This also means that no liability will be accepted for damage resulting from spreading errors. Unauthorized modifications of the RAUCH devices may result in consequential damage, for which the manufacturer will not accept any liability. The manufacturer's exclusion from liability will not apply in the case of willful intent or gross negligence by the owner or a senior employee, and in cases where – according to the product liability law – there is liability for personal injury or material damage to privately used objects in the event of defects in the supplied product. The exclusion from liability will also not apply if characteristics are missing that are explicitly guaranteed, if the purpose of their guarantee was to protect the purchaser against damage not suffered by the supplied product itself.

RAUCH Streutabellen
RAUCH Fertilizer Chart
Tableaux d'épandage RAUCH
Tabele wysiewu RAUCH
RAUCH Strooitabellen
RAUCH Tabella di spargimento
RAUCH Spredetabellen
RAUCH Levitystaulukot
RAUCH Spridningstabellen
RAUCH Tablas de abonado



<https://streutabellen.rauch.de/>



RAUCH Landmaschinenfabrik GmbH

Victoria Boulevard E 200
77836 Rheinmünster · Germany



info@rauch.de · www.rauch.de

Phone +49 (0) 7229/8580-0