

 **RAUCH**

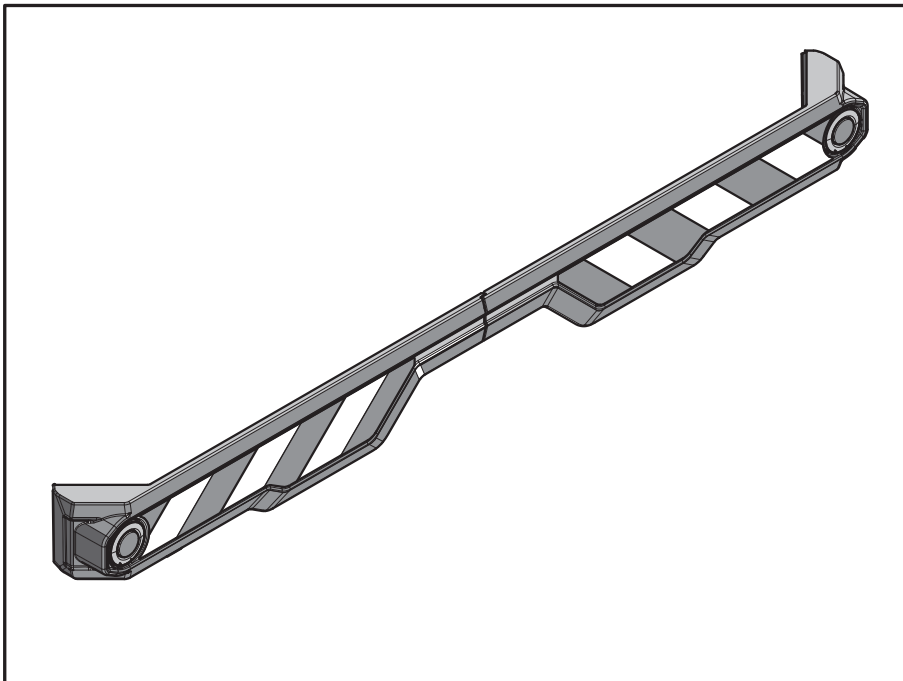

BLW 50.2

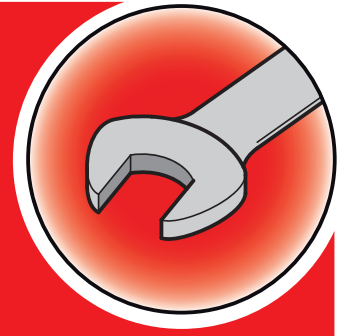

AXIS

RE0018TL_02

5901685-C-int-0323



Wichtig

de

Sicherheits- und Unfallverhütungsvorschriften

Vor etwaigen Einstell- oder sonstigen Arbeiten z.B. Reinigung, Wartung, Umbau oder Anbau **Zapfwelle ausschalten, Motor abstellen und Zündschlüssel abziehen.**

Beachten Sie auch die Sicherheitshinweise in der Betriebsanleitung zu diesem Zubehör!



Important

en

Accident prevention and safety regulations

Always disconnect the PTO (power take-off) , shut down the engine and remove the ignition key before carrying out any adjustments or other work on the machine (e.g. cleaning, maintenance, additions or modifications).

Refer also to the safety instructions in the user manual provided with the fittings.



Important

fr

Consignes de sécurité et de prévention des accidents

Avant d'éventuels travaux de réglage ou autres, par exemple nettoyage, entretien, transformation ou ajout, **désactiver la prise de force, arrêter le moteur et retirer la clé de contact.**

Respecter également les consignes de sécurité figurant dans le manuel d'utilisation de cet accessoire !



Importante

it

Norme di sicurezza e antinfortunistiche

Prima di qualsiasi intervento di regolazione o lavoro, ad es. pulizia, manutenzione, modifica o montaggio

disinserire la presa di forza, spegnere il motore ed estrarre la chiave dell'accensione.

Rispettare anche le norme di sicurezza contenute nel manuale d'uso di questo accessorio!



Belangrijk

nl

Veiligheids- en ongevalpreventievoorschriften

Voor alle instel- of andere werkzaamheden, bijv. reiniging, onderhoud, ombouwen of aanbouwen **de aftakas uitschakelen, de motor uitzetten en de contactsleutel uit het contactslot trekken.**

Neem ook de veiligheidsinstructies in de bedieningshandleiding ten aanzien van dit accessoire in acht!



Viktigt

sv

Föreskrifter om säkerhet och olycksförebyggande åtgärder

Före inställningar eller andra arbete som t.ex. rengöring, underhåll, ombyggnad eller montering **Stäng av kraftuttaget och motorn samt ta ut tändningsnyckeln.**

Beakta även säkerhetsinformationen i bruksanvisningen för de aktuella tillbehören!



Importante

es

Normativa para la seguridad y prevención de accidentes

Previo a las labores de ajuste o de cualquier otro tipo como, p. ej., limpieza, mantenimiento, modificación o montaje,

desacople el eje de toma de fuerza, apague el motor y extraiga la llave de encendido.

¡Observe asimismo las indicaciones de seguridad contenidas en el manual de instrucciones de este accesorio!



Fontos

hu

Biztonsági és balesetvédelmi előírások

A gép beállítása vagy egyéb munkálatai előtt (pl. tisztítás, karbantartás, átépítés vagy felszerelés) **kapcsolja ki az erőleadó tengelyt, állítsa le a motort és húzza ki a gyújtáskulcsot.**

Ügyeljen a tartozék kezelési útmutatójában található biztonsági tudnivalók betartására.



Viktig

no

Sikkerhets- og ulykkesforebyggende forskrifter

Før eventuelle innstillings- eller andre arbeider som f.eks. rengjøring, vedlikehold, ombygging eller påbygging:

Koble ut tappakselen, slå av motoren og trekk ut tenningsnøkkelen.

Følg også sikkerhetsanvisningene i bruksanvisningen for dette tilbehøret!



Tärkeätä

fi

Turvallisuusmääräykset

Voimanottoakseli on kytkettävä irti, moottori sammutettava ja virta-avain vedettävä irti virtalukosta ennen kaikkia säätö- tai muita toimia kuten esim. puhdistusta, huoltoa, muutostöitä tai lisälaitteiden kytkemistä.

Noudata myös lisävarusteiden käyttöohjeissa olevia turvallisuuteen liittyviä neuvoja!



Wichtig

lb

Virschräfte fir d'Sécherheet a fir Onfäll ze vermeiden

Virun eventuellen Astellungen oder aneren Aarbechten, wéi z.B. Botzen, Manutentioun, Ännerungen oder Erweiterungen,

d'prise de force ausmaachen, de Motor ausmaachen an de Schlëssel erauszéien.

Halt lech w.e.g. och un d'Indikatioune fir d'Sécherheet, déi Dir am Handbuch vun dësem Accessoire fannt!



Ważne

pl

Przepisy bezpieczeństwa i zapobiegania wypadkom

Przed rozpoczęciem wszelkich prac nastawczych lub innych, np. czyszczenie, konserwacja, przebudowa lub montaż

Wyłączyć wał odbioru mocy, zatrzymać silnik i wyciągnąć kluczyk ze stacyjki.

Przestrzegać również wskazówek dotyczących bezpieczeństwa zamieszczonych w instrukcji obsługi tego urządzenia!



Vigtigt

da

Forskrifter om sikkerhed og forebyggelse af ulykker

Før eventuel indstilling eller andet arbejde, f.eks. rengøring, vedligeholdelse, ombygning eller påmontering af dele, skal **kraftudtaget frakobles, motoren standses og tændingsnøglen trækkes ud.**

Følg også sikkerhedsanvisningerne i driftsvejledningen til dette tilbehør!



Važno

hr

Propisi o sigurnosti i sprječavanju nezgode

Prije eventualnih podešavanja ili ostalih radova npr. čišćenja, održavanja, prepravljanja ili montaže

isključite prijenosnik snage, ugasite motor i izvucite ključeve za paljenje.

Uvažite i upute o sigurnosti iz uputa za upotrebu ovog pribora!



Önemli

tr

Güvenlik ve kaza önleme ile ilgili talimatlar

Muhtemel ayar çal işmlarından veya diğer işlerden örn. temizlik, bakım, tadilat veya montaj **muylu mili kapat in, motoru durdurun ve kontak anahtarını çıkarın.**

Bu aksesuarın kullanım kılavuzundaki emniyet talimatlarını da dikkate alın !



Importante

pt

Normas de segurança e prevenção de acidentes

Antes de qualquer trabalho de ajuste ou de outra natureza, como limpeza, manutenção, modificação ou montagem,

desligar o eixo de tomada de força, desligar o motor e retirar a chave da ignição.

Devem também ser tidas em conta as recomendações de segurança constantes do manual de instruções deste acessório!



Pomembno

Varnostni predpisi in predpisi za preprečevanje nesreč

Pred namestitvijo ali drugimi deli ali posegi, na primer čiščenjem, vzdrževanjem, rekonstrukcijo ali montažo, **izklopite kardansko gred, zaustavite motor in izvlecite ključ za vžig.**

sl

Upoštevajte tudi varnostne napotke v navodilih za uporabo te opreme!



Dôležitě

Bezpečnostné predpisy a predpisy na prevenciu úrazov

Pred prípadnými nastavovacími alebo inými prácami, ako napr. čistením, údržbou, rekonštrukciou alebo pristavovaním, **vypnite vývodový hriadeľ, odstavte motor a vytiahnite kúč zo zapalovania.**

sk

Dbajte pritom tiež na bezpečnostné pokyny v návode na obsluhu k tomuto príslušenstvu!



Tähtis

Ohutus- ja ettevaatuseeskirjad

Enne võimalikke seadistus- vm töid, näiteks puhastamine, hooldus, ümber- või juurdeehitus, **tuleb käitusvõlli välja lülitada, mootor seisata ja süütevõti eemaldada.**

et

Järgige ka kõnealuse varustuse Kasutusjuhendis sisalduvaid ohutusjuhiseid!



Svarbu

Saugos ir atsargumo priemonių instrukcijos

Montuojant arba atliekant panašius darbus, pvz., valant, atliekant techninę priežiūrą, atliekant permontavimo arba papildomų įrenginių montavimo darbus **būtina atjungti papildomą ają pavarą, išjungti variklį ištraukti užvedimo raktelį.**

lt

Taip pat laikykitės šio įrenginio eksploatavimo vadove pateiktų saugos nurodymų!



Svarīgi

Norādes drošībai un nelaiemes gadījumu novēršanai.

Pirms iespējamiem iestatīšanas vai citiem darbiem, piemēram, tīrīšanas, apkopes, pārbūves vai piebūvēšanas **atslēdziet jūgvārpstu, izslēdziet motoru un izņemiet aizdedzes atslēgu.**

lv

Ievērojiet arī drošības norādes, kas minētas šī piederuma ekspluatācijas instrukcijā!



Důležitě

Bezpečnostní předpisy a předpisy pro ochranu před úrazem

Před případným seřizováním nebo jinou prací, např. čištění, údržba, přestavba nebo montáž, **vypněte vývodovou hřídel, vypněte motor a vytáhněte klíček ze zapalování.**

cs

Dodržujte také bezpečnostní pokyny v návodu k obsluze tohoto příslušenství!



Važno

Propisi za zaštitu na radu i sprečavanje nesreća

Pre eventualnih podešavanja ili ostalih radova npr. čišćenja, održavanja, prepravljanja ili montaže **isključite prenosnik snage, ugastite motor i izvucite ključeve za paljenje.**

sr

Obratite pažnju i na uputstva za zaštitu na radu iz uputstva za upotrebu ovog pribora!



Tábhachtach

Rialúcháin um shábháilteacht agus seachaint timpistí

Déan i gcónaí an Cumhachtdhúiseoir a dhínascadh, an t-inneall a mhúchadh agus an eochair adhainte a bhaint as sula ndéanann tú aon choigeartú nó obair eile ar an meaisín (m.sh. glanadh, cothabháil, breiseáin nó mionathruithe).

ga

Féach freisin na treoracha sábháilteachta i lámhleabhar an úsáideora, a cuireadh ar fáil i dteannta na bhfeisteas seo.



Áriðandi

is

Öryggisleiðbeiningar og fyrirmæli vegna slysa hættu

Á undan stillingavinnu eða öðru viðhaldi t.d. hreinsun, viðgerðum, breytingum eða viðbótum verður að **taka drifskafið úr sambandi, slökkva á mótornum og fjarlægja kveikjulykil.**

Farið einnig eftir öryggisleiðbeiningum í notendahandbókinni sem fylgir þessum búnaði!



Σημαντικό

el

Οδηγίες ασφαλείας και πρόληψης ατυχημάτων

Πριν από κάθε ρύθμιση ή οποιαδήποτε άλλη εργασία, όπως π.χ. καθαρισμός, συντήρηση, τροποποίηση ή επέκταση

απενεργοποιήστε τον κινητήριο άξονα και τον κινητήρα και τραβήξτε το κλειδί ανάφλεξης.

Λάβετε υπόψη και τις υποδείξεις ασφαλείας του εξοπλισμού αυτού, που περιέχονται στο παρόν εγχειρίδιο λειτουργίας!



Важно

ru

Предписания по технике безопасности и правила безопасности

Перед выполнением настройки или других работ, например чистки, технического обслуживания, переоборудования или установки, **выключите вал отбора мощности, отключите двигатель и выньте ключ зажигания.**

Выполняйте указания по технике безопасности, содержащиеся в инструкции по эксплуатации этих принадлежностей!



Увага!

uk

Вказівки з техніки безпеки та запобігання нещасним випадкам

Перед виконанням будь-яких установочних чи інших робіт, таких як чищення, технічне обслуговування, монтаж або демонтаж, **необхідно зупинити розподільчий вал, вимкнути мотор та витягнути ключ запалення.**

Також дотримуйтеся вказівок з техніки безпеки, що подані в інструкції з користування обладнанням!



Важно

bg

Правила по техника на безопасност и охрана на труда

Преди евентуални работи по настройката или други работи, напр. почистване, поддръжка, реконструкция или пристрояване

изключете силоотводния вал, спрете двигателя и извадете ключа за запалването.

Съблюдавайте и инструкциите по безопасността в ръководството за работа към тези принадлежности!



Important

ro

Prevederi de siguranță și prevenire a accidentelor

Înainte de orice lucrări de instalare sau de alt fel, cum ar fi curățarea, întreținerea, modificarea sau montarea de piese suplimentare **a se decupla priza de putere, a se opri motorul și a se scoate cheia de contact.**

Respectați și indicațiile de siguranță din manualul de utilizare al acestui accesoriu!



重要

ja

安全規定および 事故防止規定

調整作業または清掃、メンテナンス、改造、取り付けなどの作業を行う際は、あらかじめ動力取り出し装置の電源を切り、エンジンを停止させ、イグニッションキーを抜いてください。

また、本付属品の取扱説明書に記載されている安全上の注意事項も守ってください！

1a BLW 50.2 **AXIS 50**

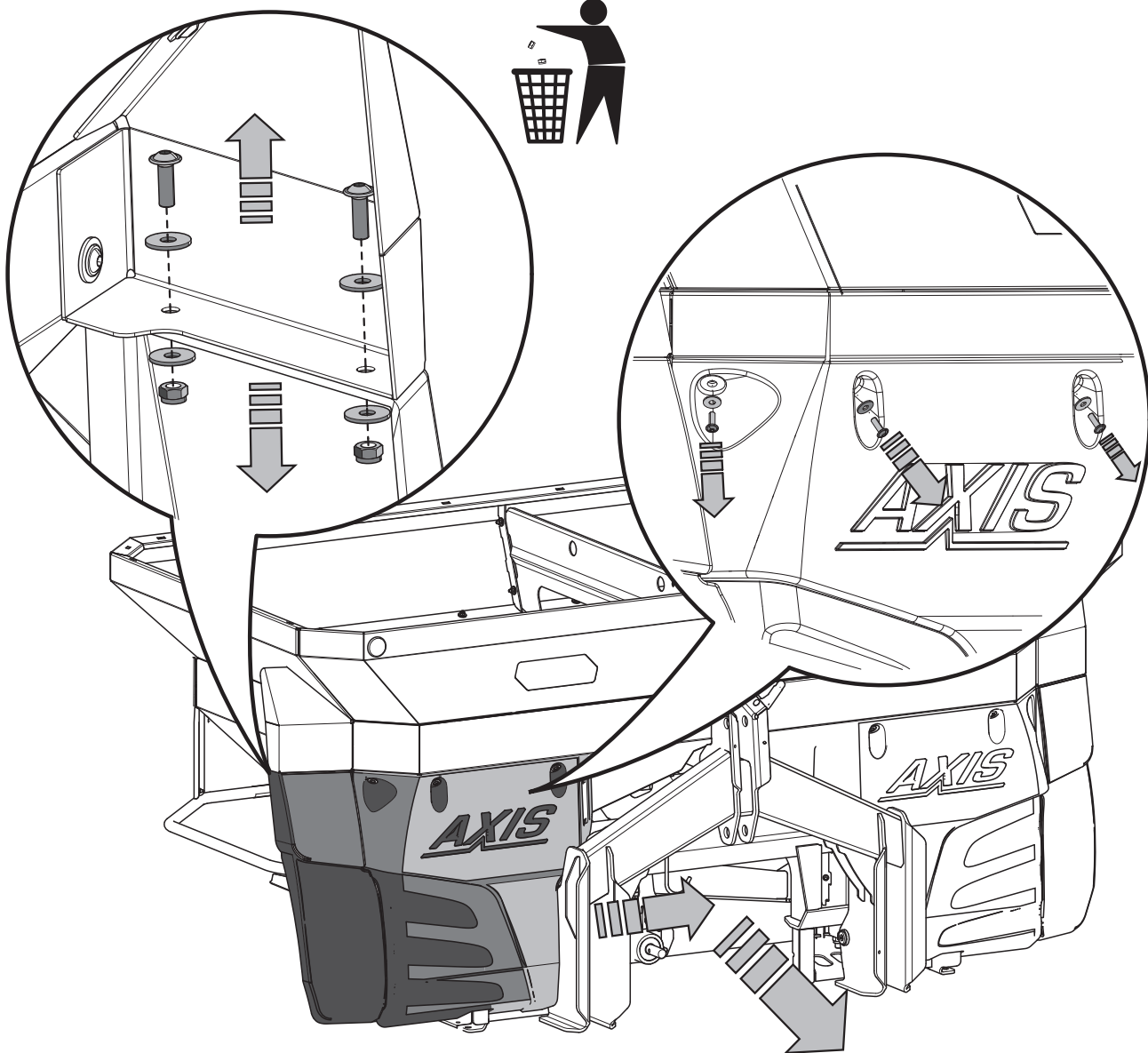
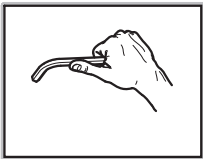

1b BLW 50.2 **AXIS 50**

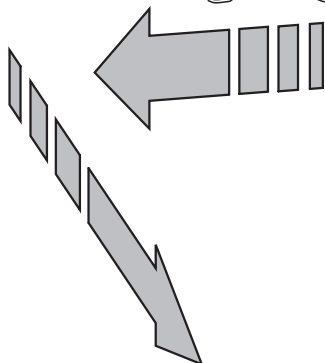
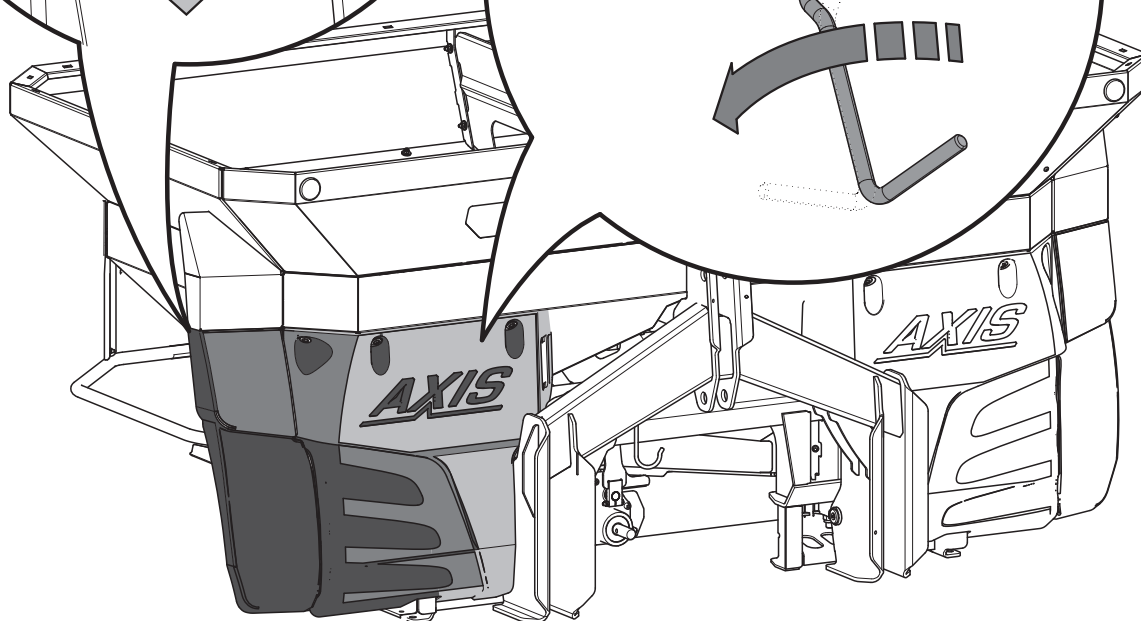
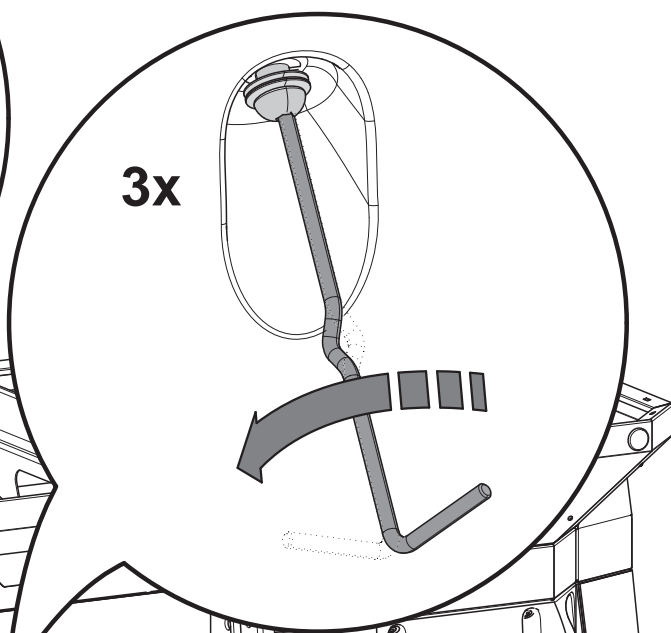
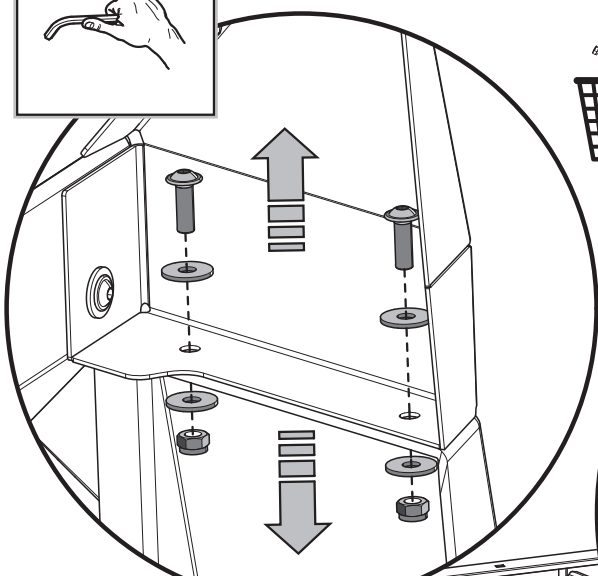
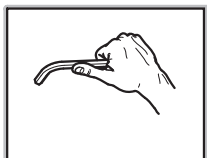

2a

BLW 50.2

AXIS 50

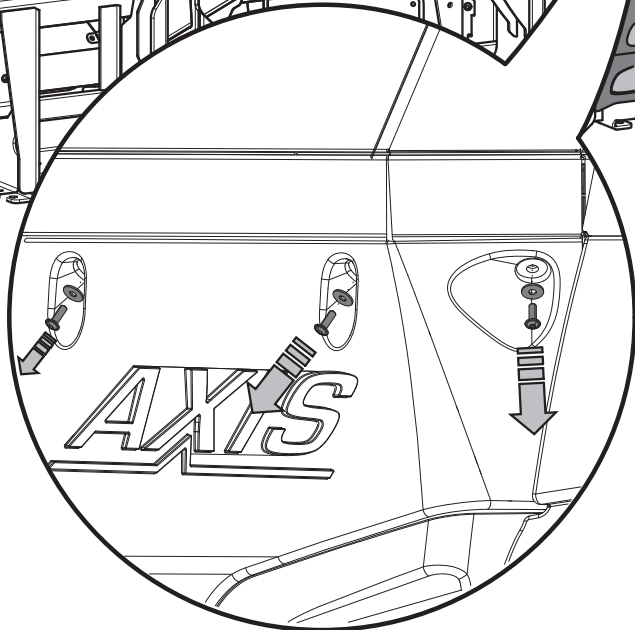
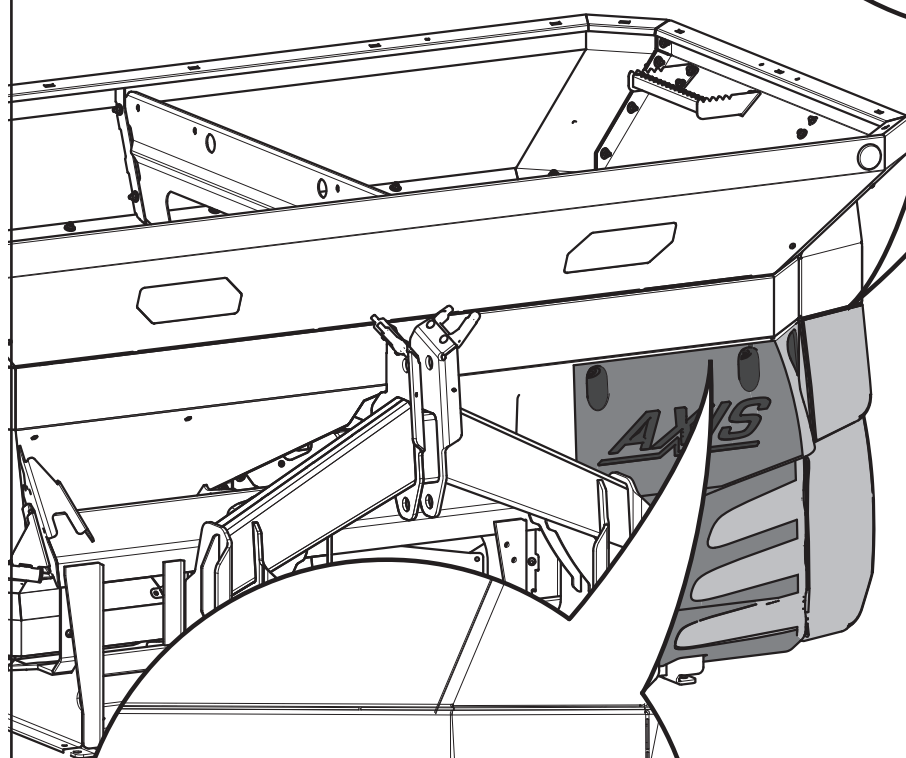
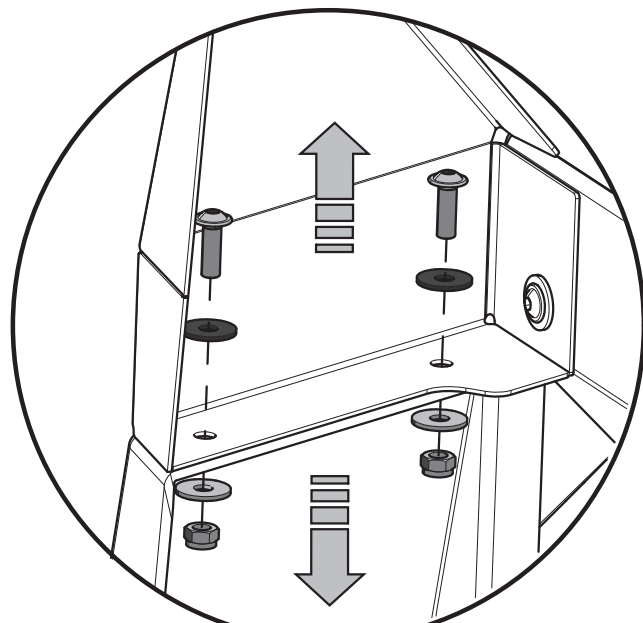
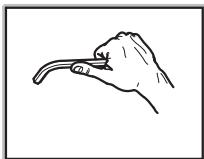

2b

BLW 50.2

AXIS 50

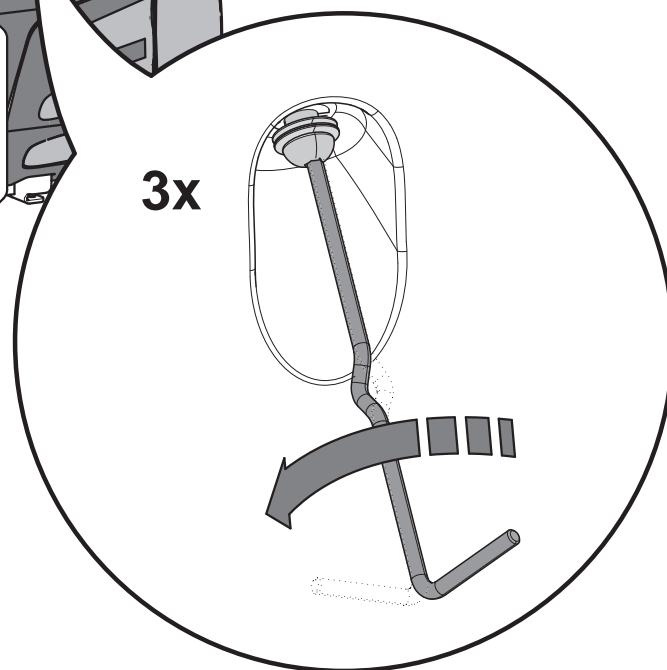
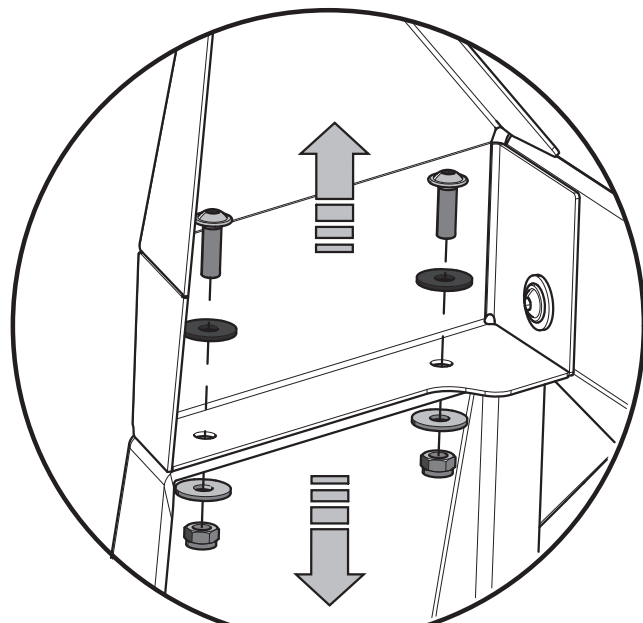
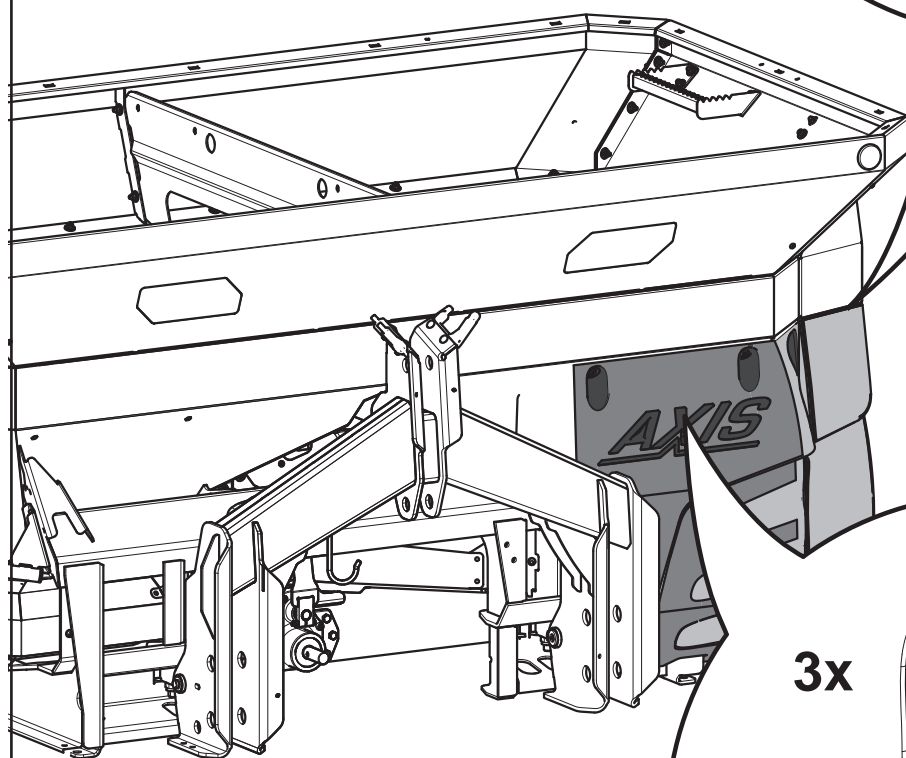
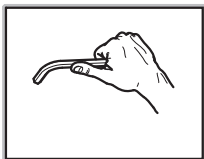

(3)

BLW 50.2

AXIS 50 H EMC / H EMC+W

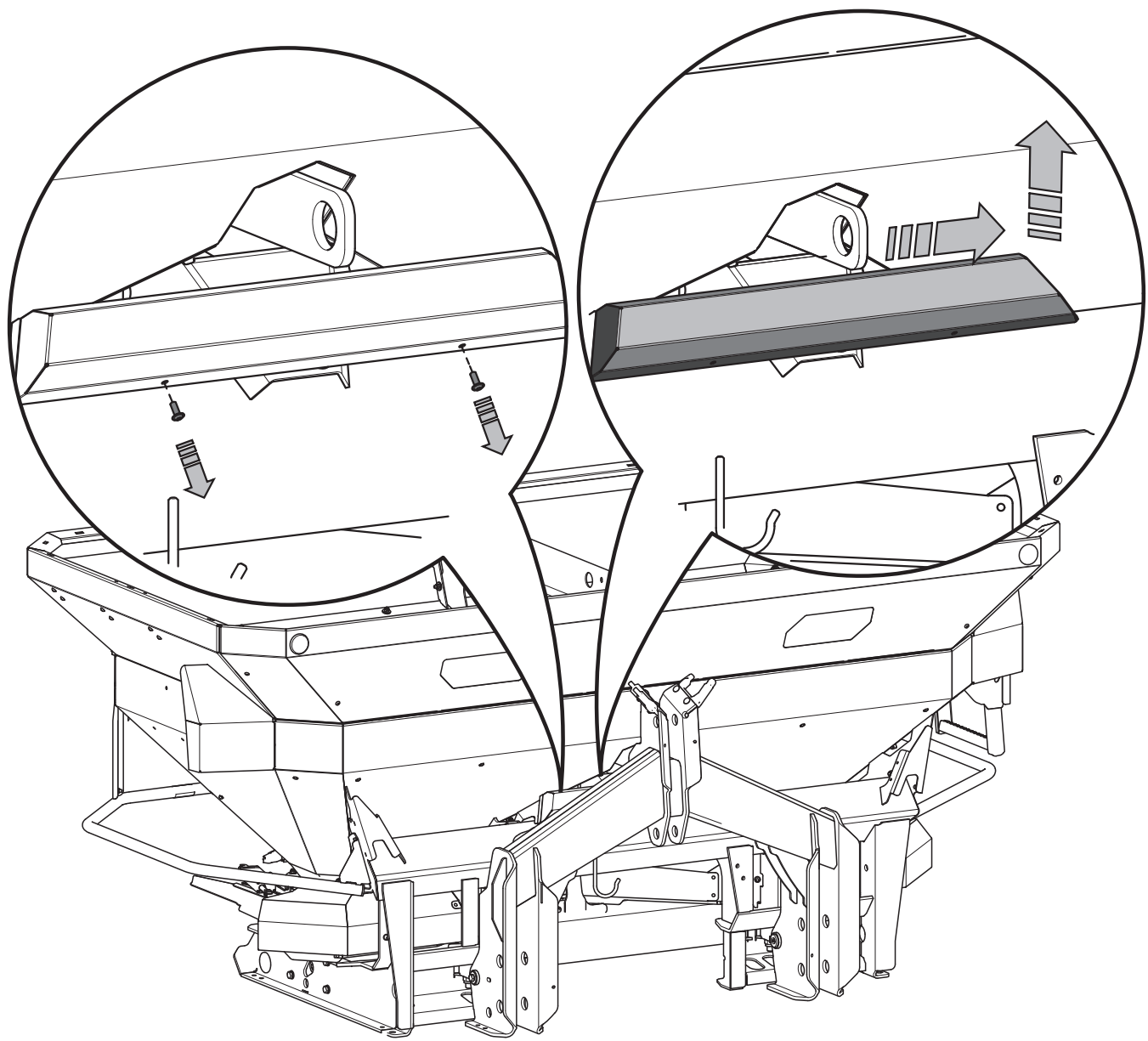
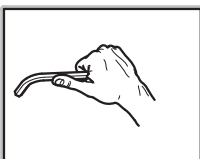

4

BLW 50.2

AXIS 50

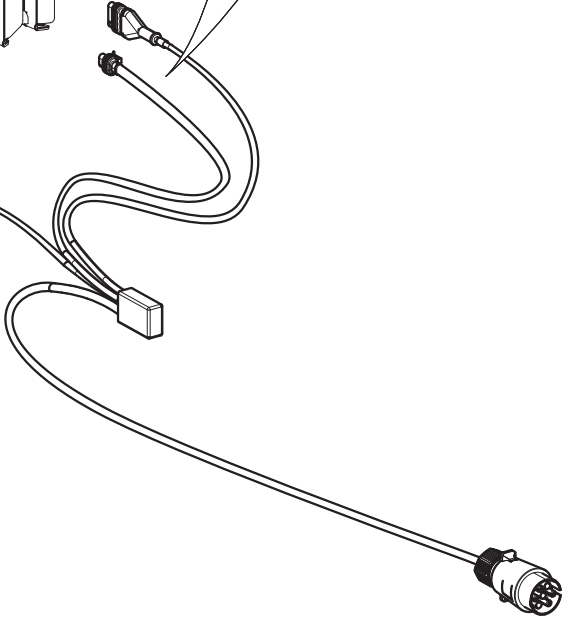
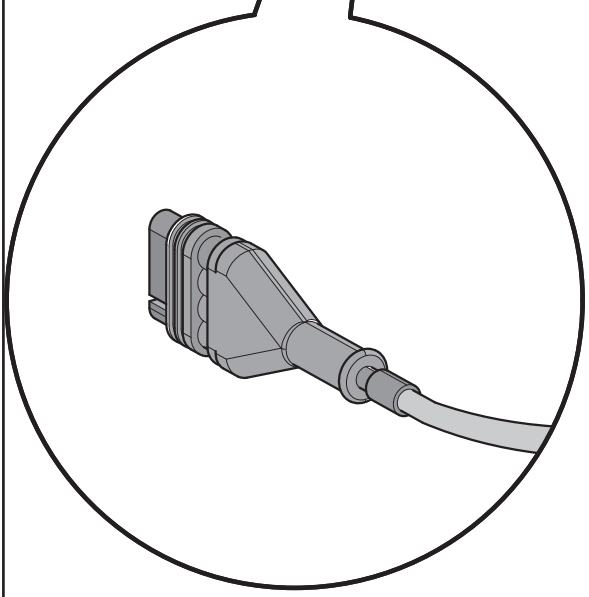
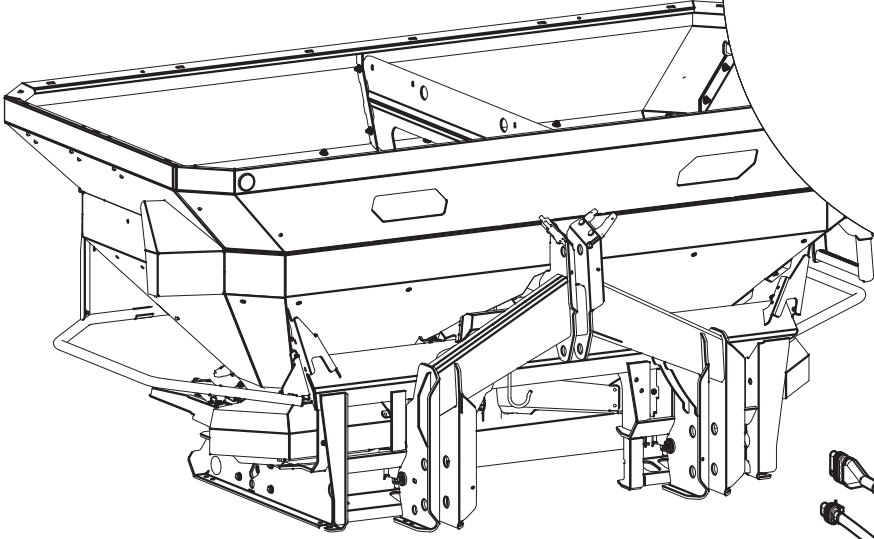
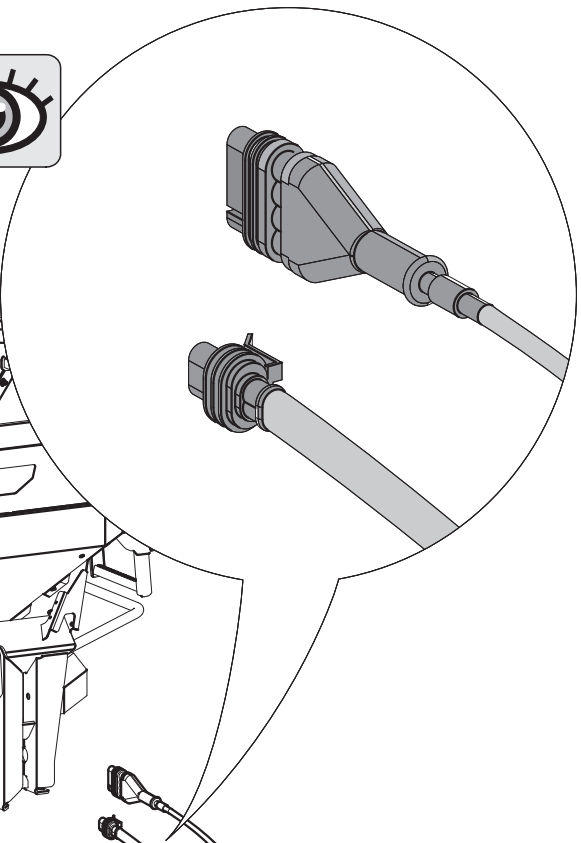

5a

BLW 50.2 **AXIS 50 H EMC / H EMC+W**

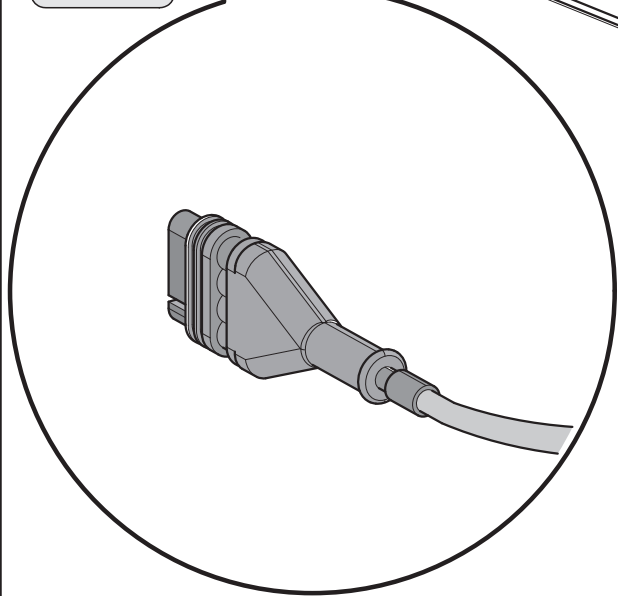
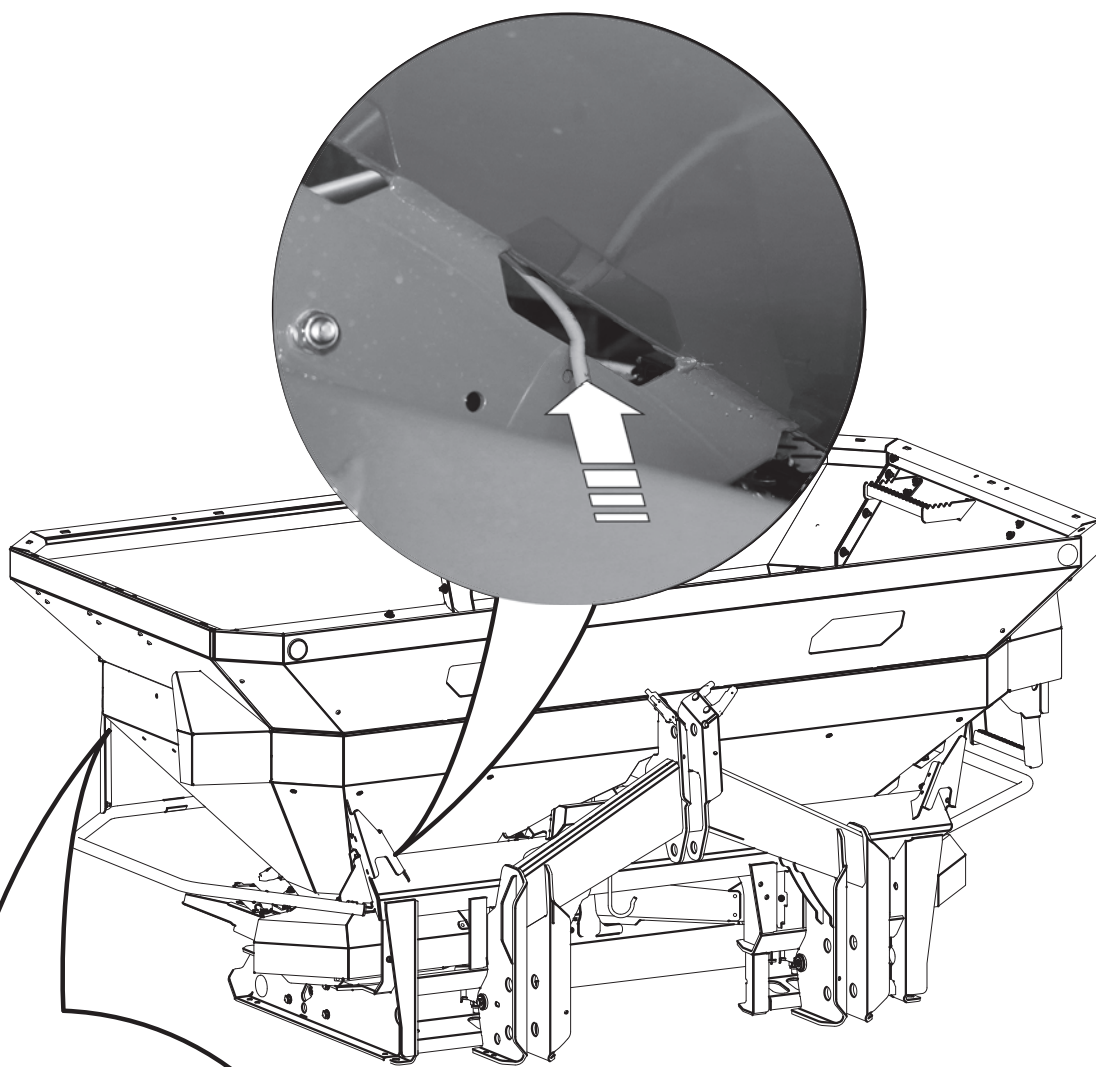

5b BLW 50.2 **AXIS 50 W**

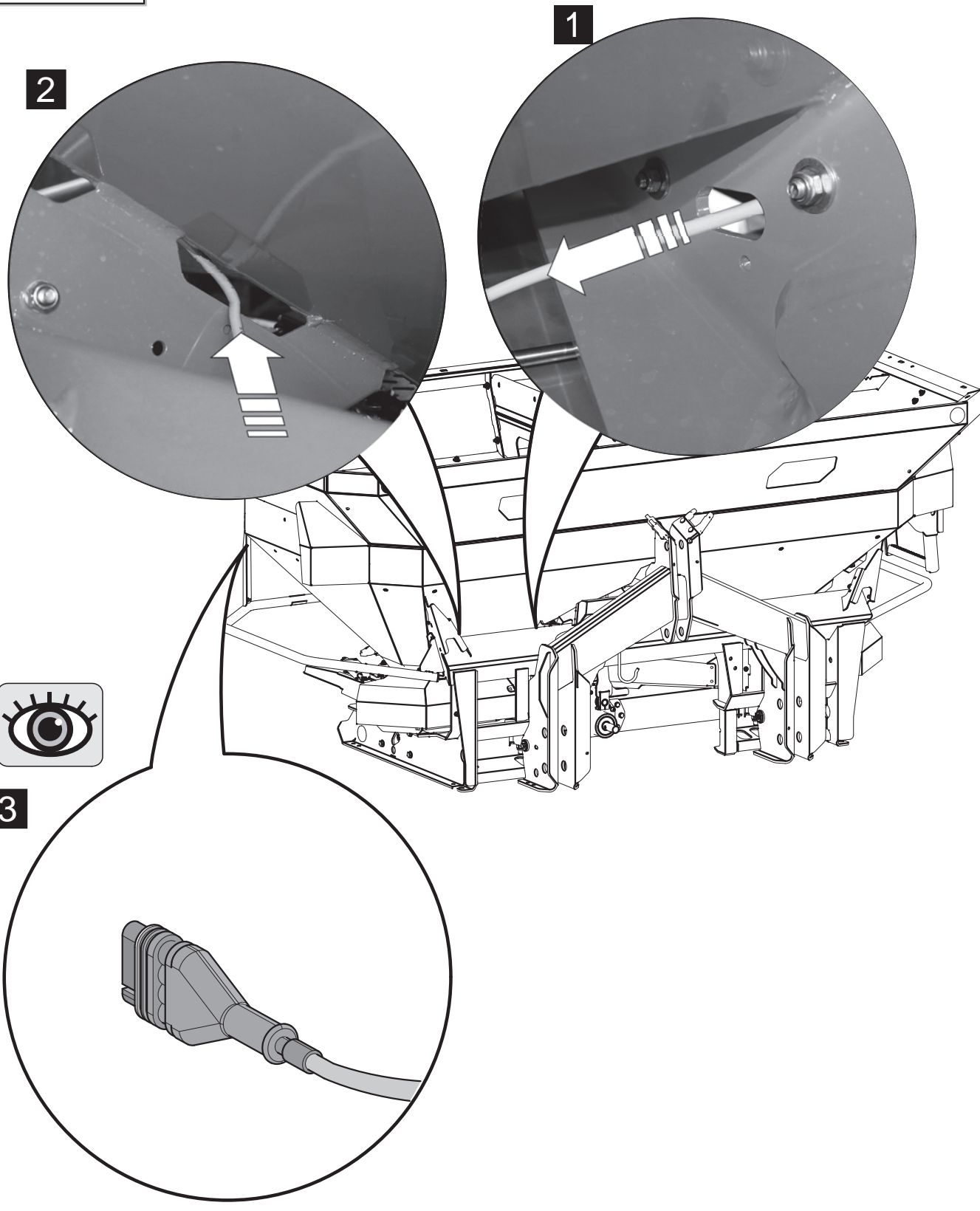

2

1



3

5c BLW 50.2 **AXIS 50 D**



1

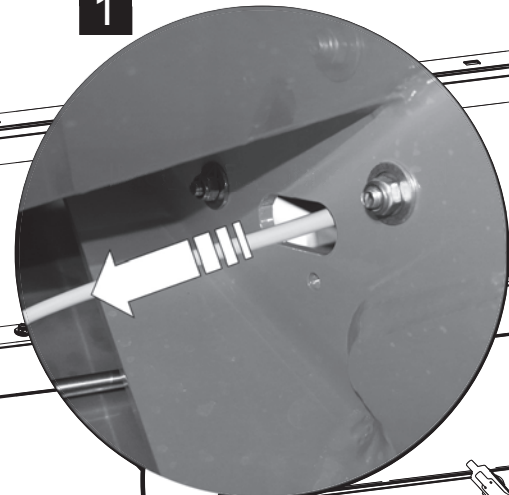

2

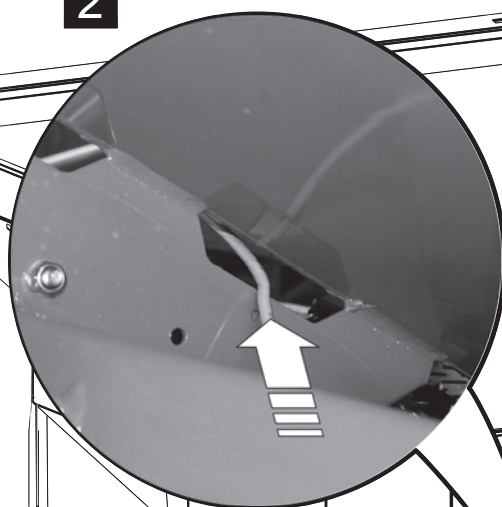

4

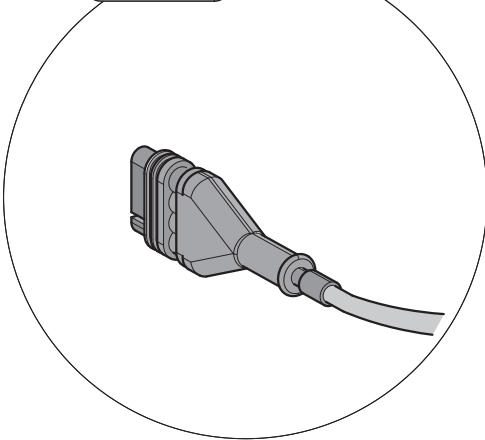

3

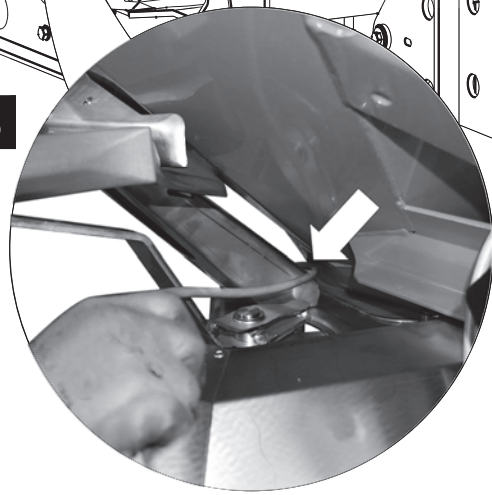



6

BLW 50.2

AXIS 50

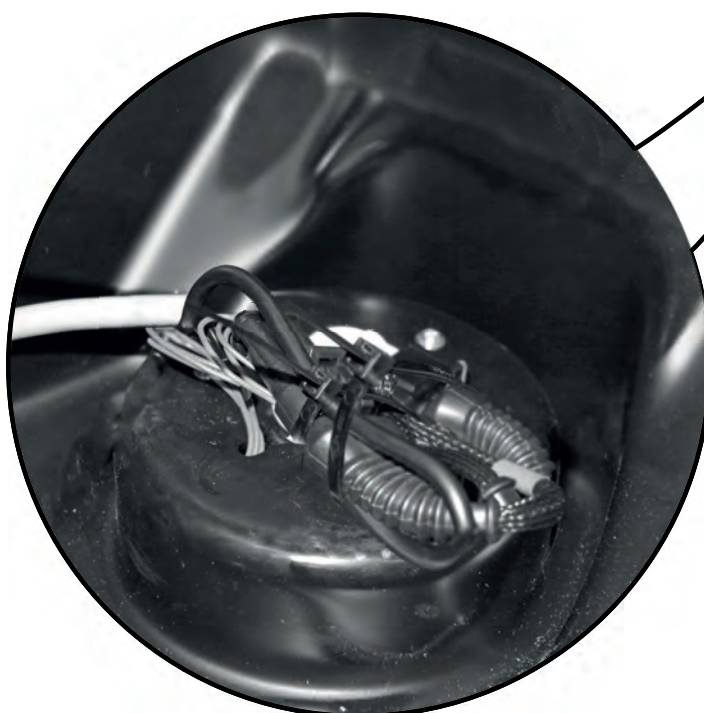
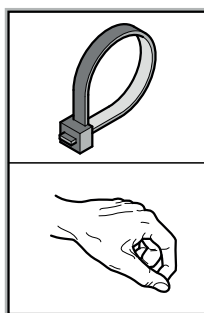
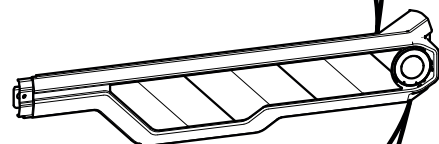
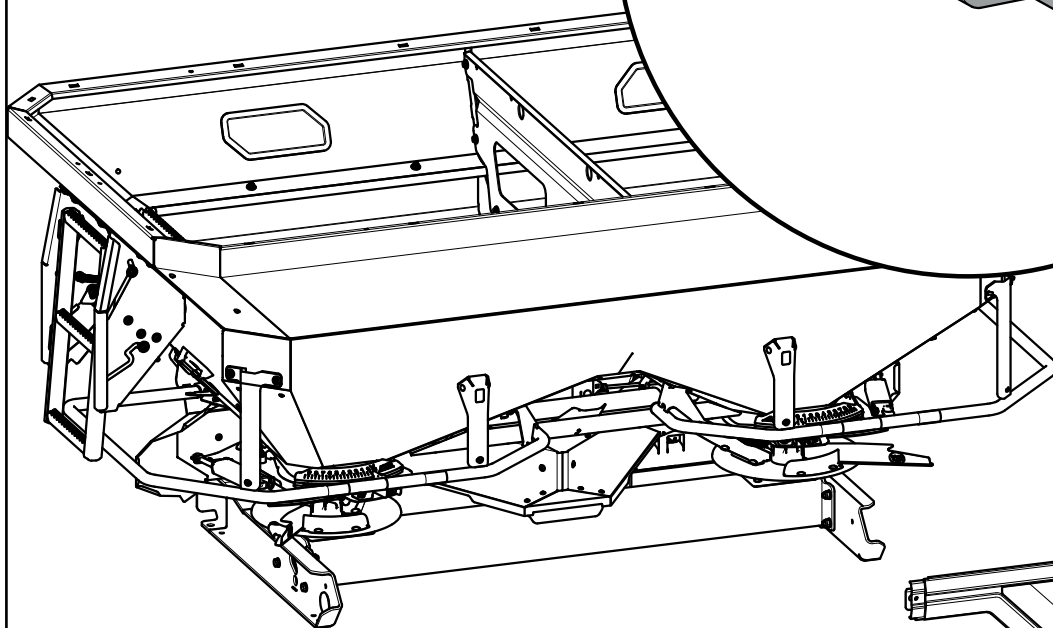
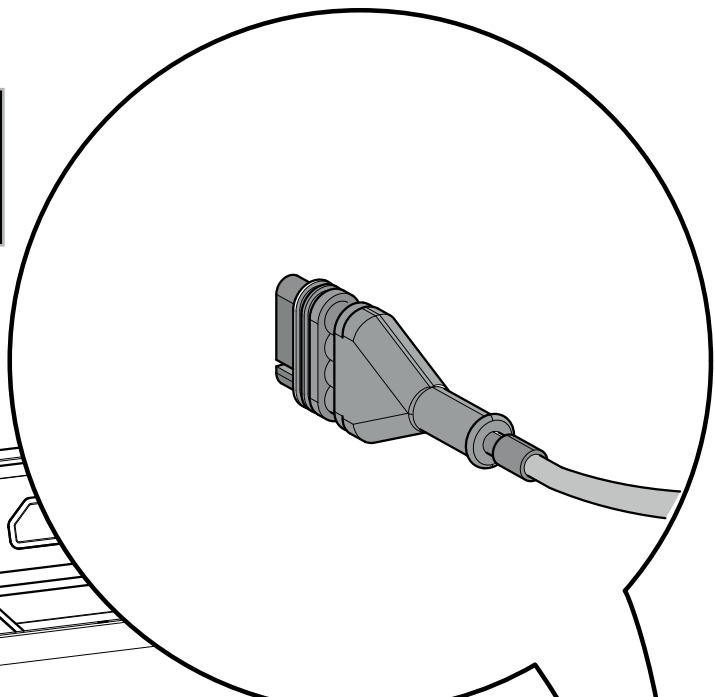
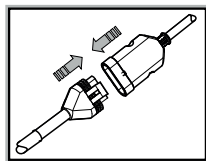



7

BLW 50.2 **AXIS 50**

3x



M 8x25

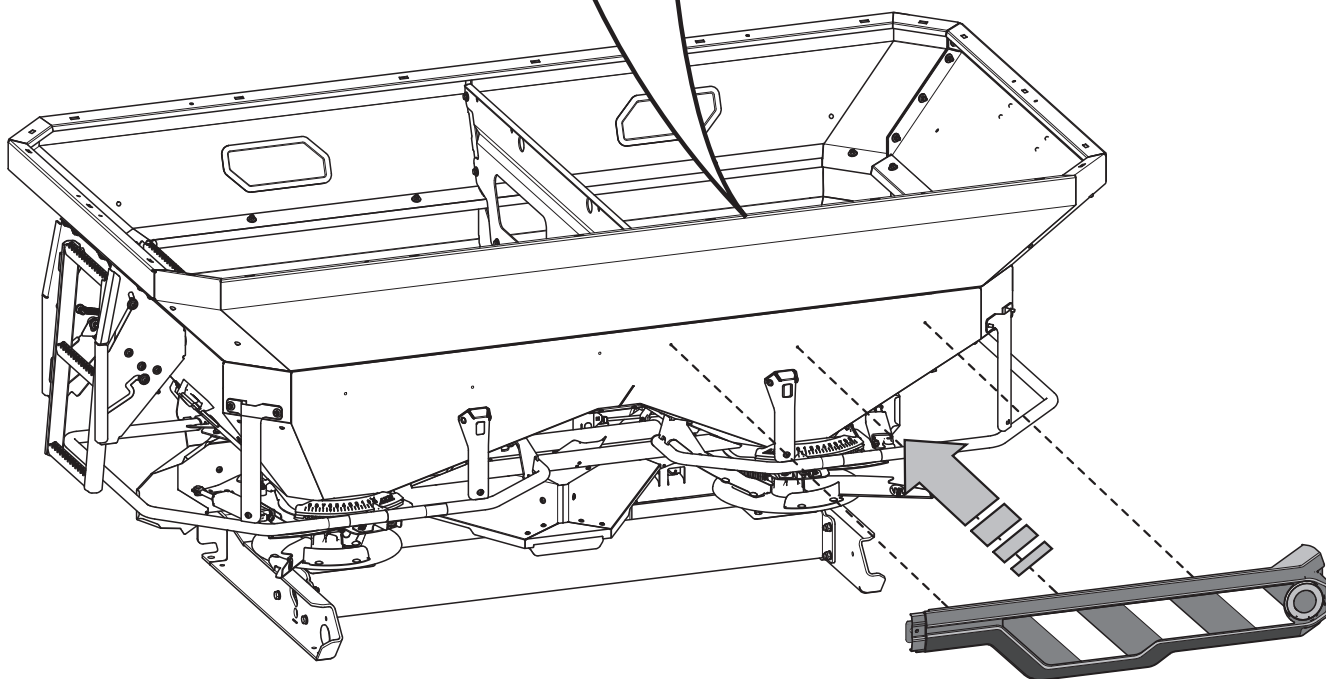
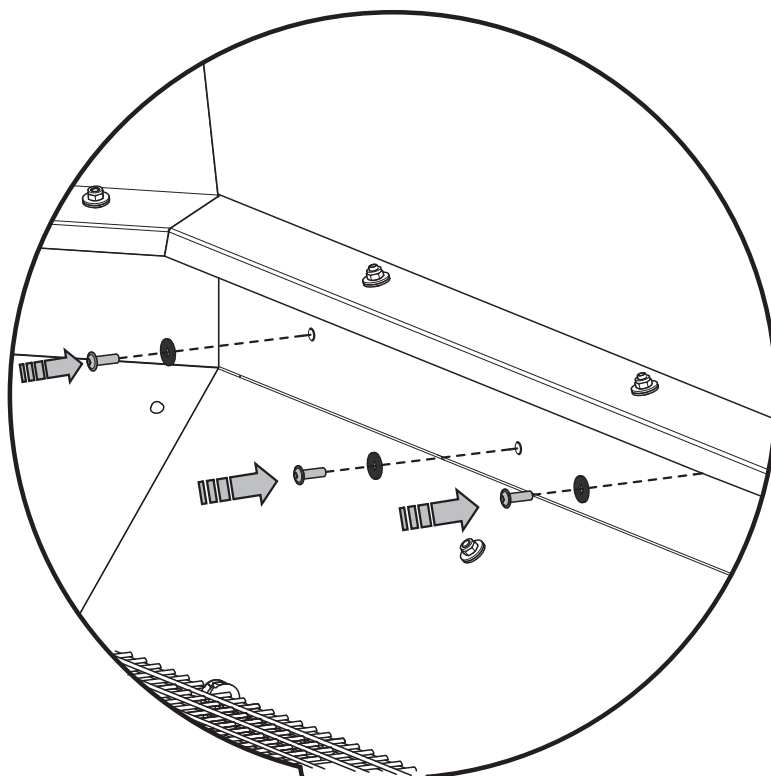
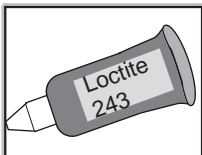



8

BLW 50.2

AXIS 50

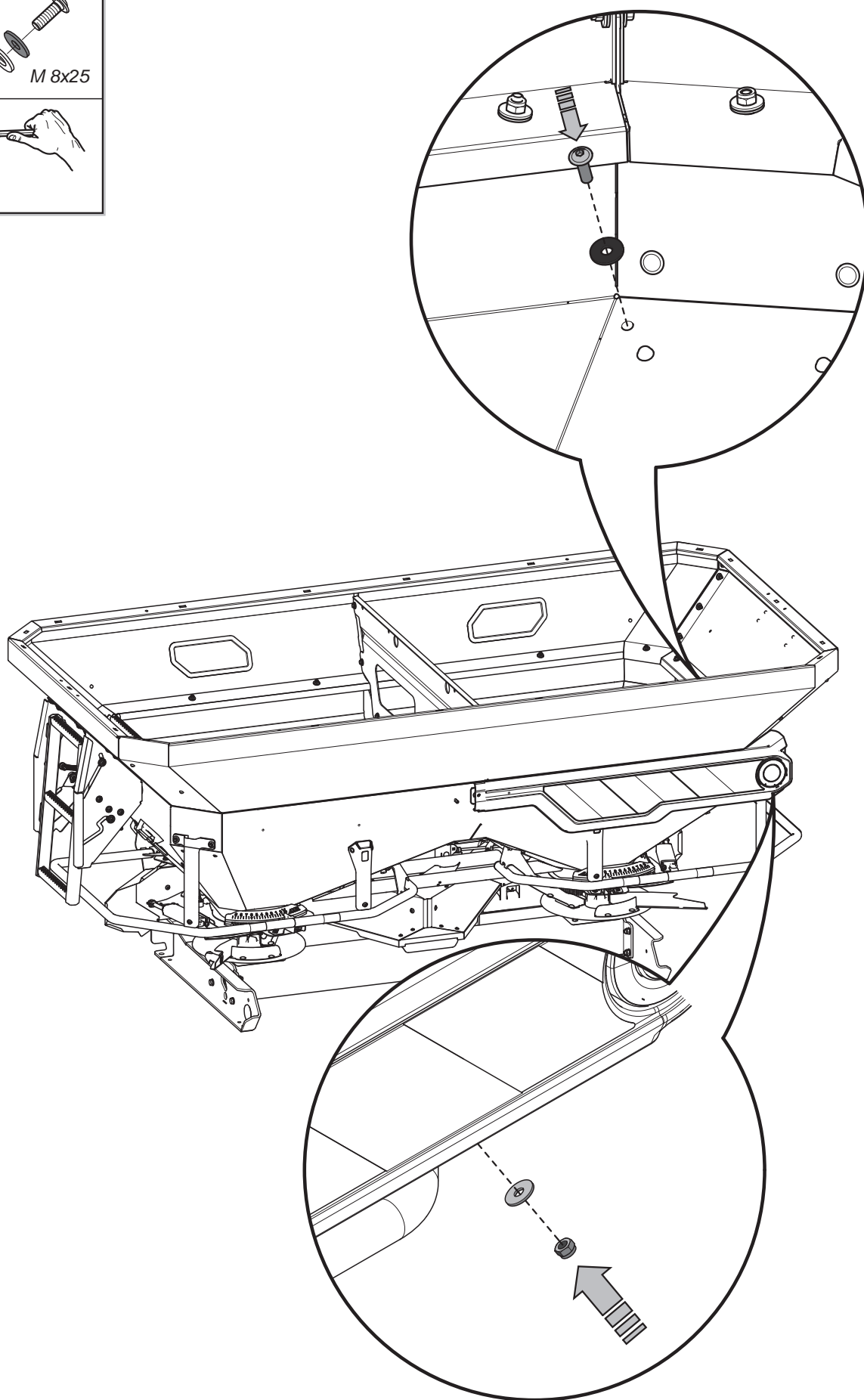
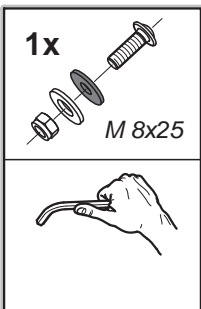



9

BLW 50.2

AXIS 50

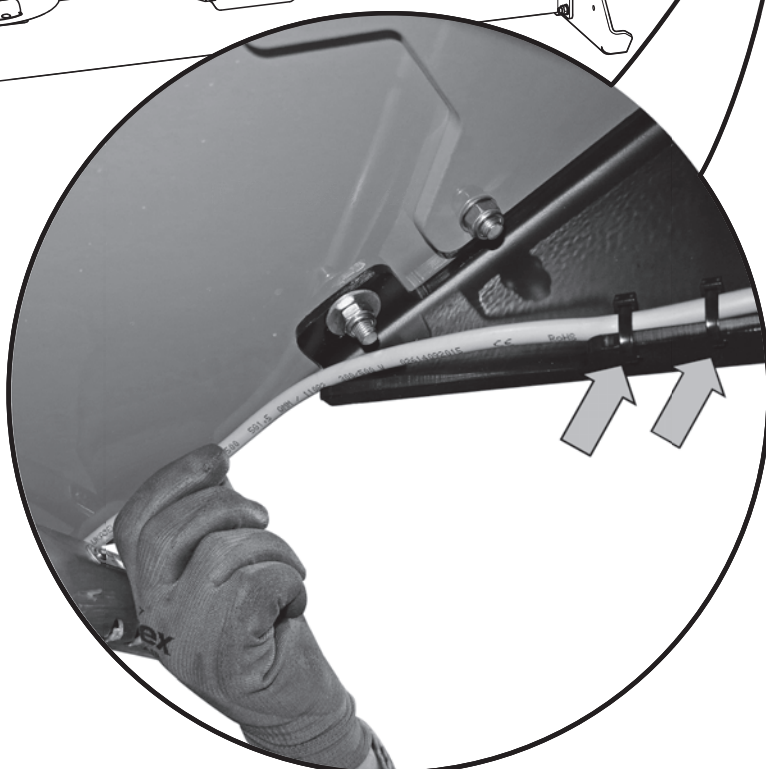
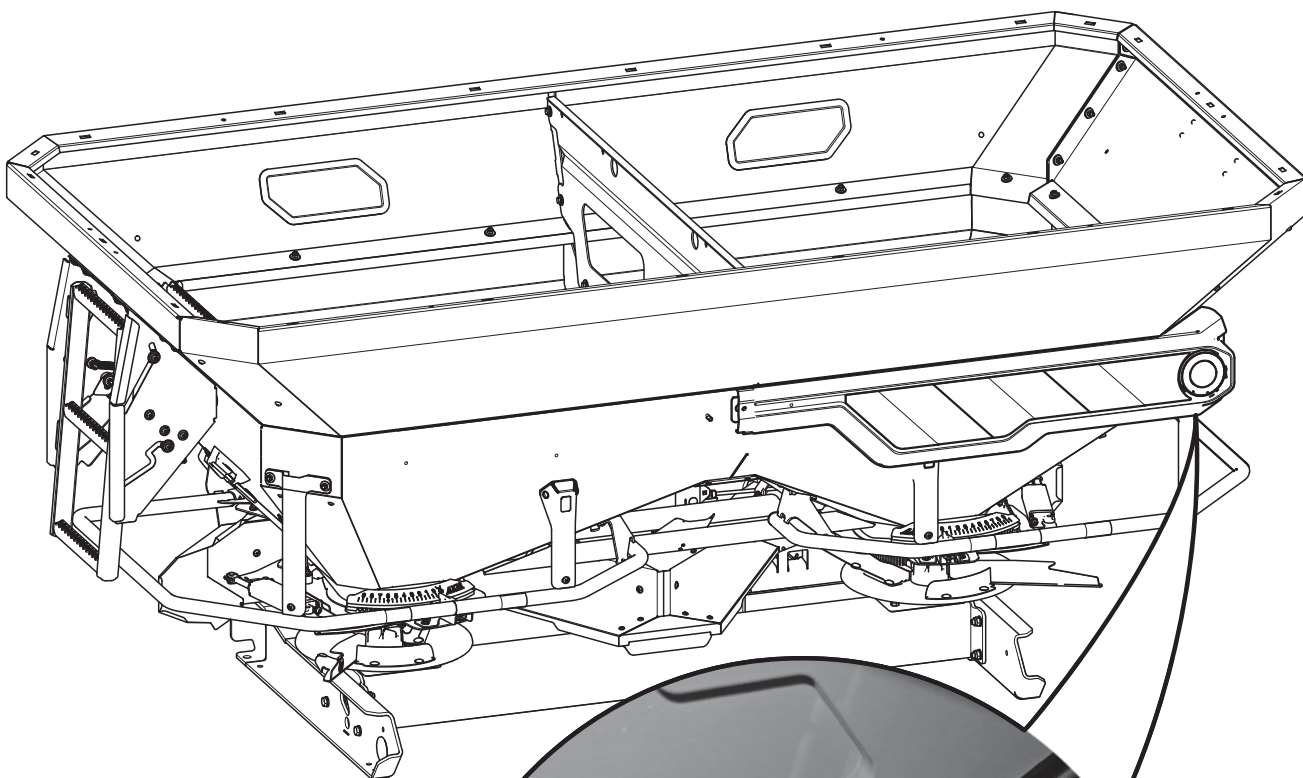
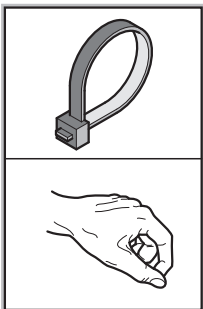

10a BLW 50.2 **AXIS 50 H EMC / H EMC+W**

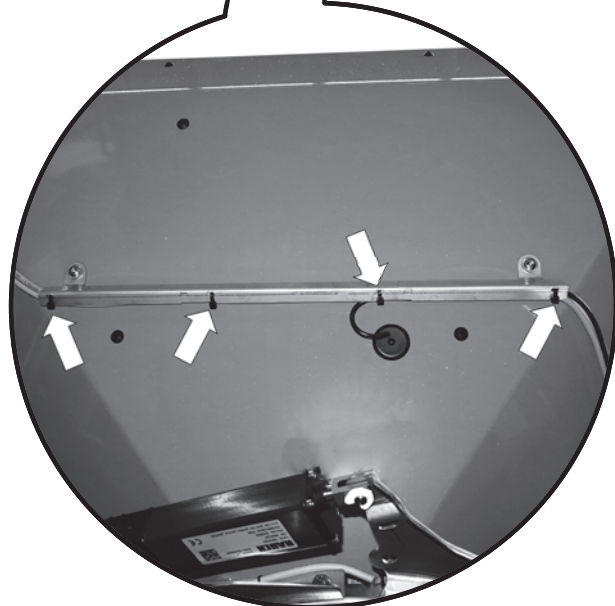
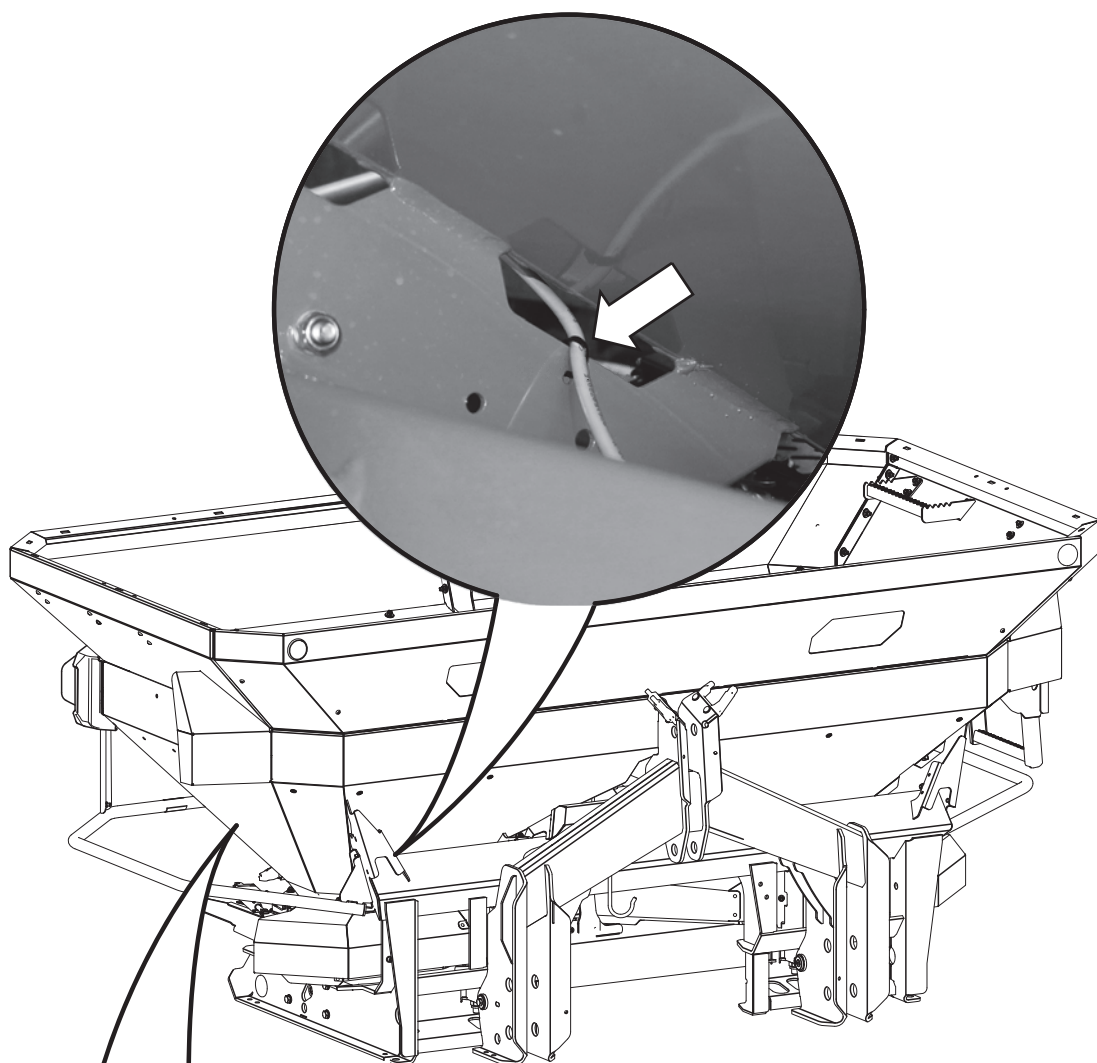
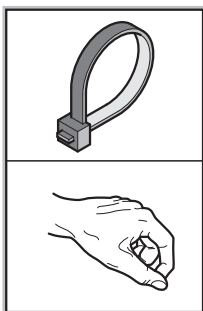

10b BLW 50.2 **AXIS 50 W**

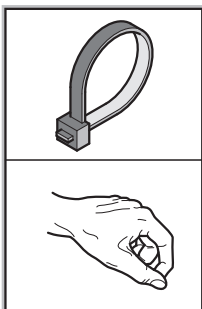

2

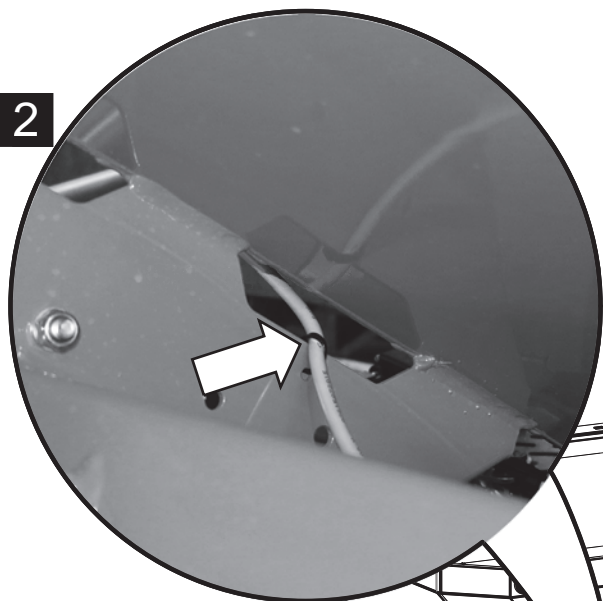

3

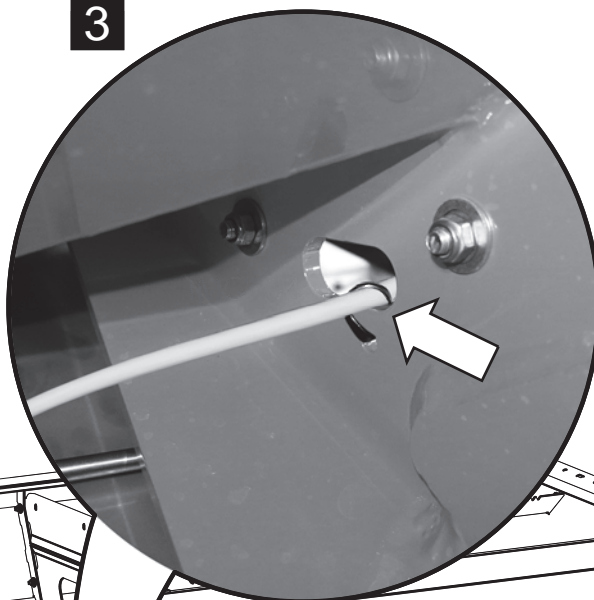

1

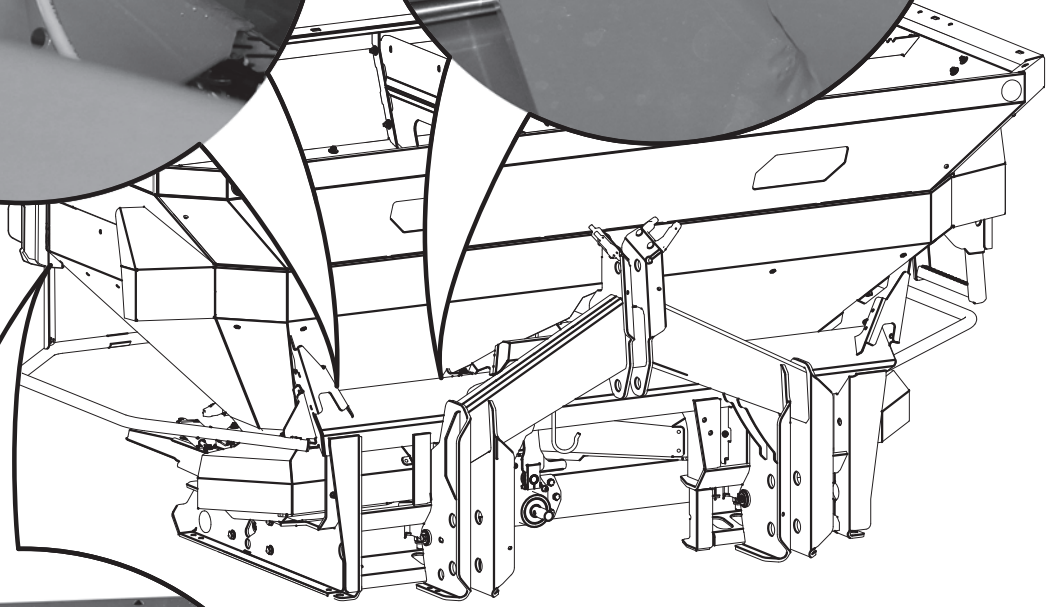
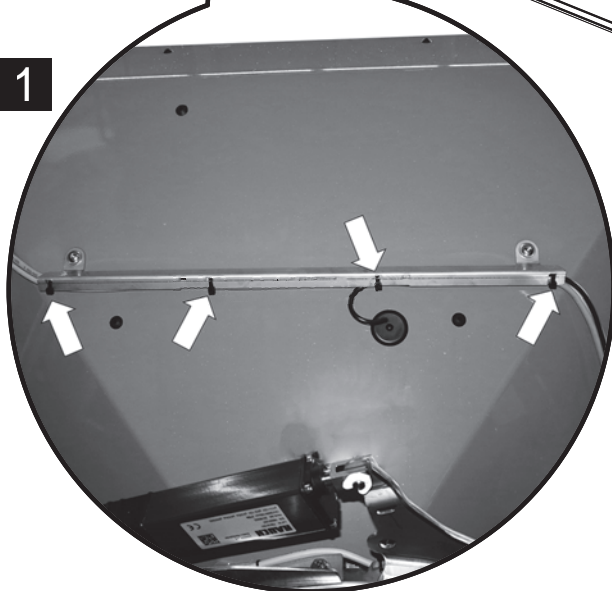

10c

BLW 50.2

AXIS 50 D

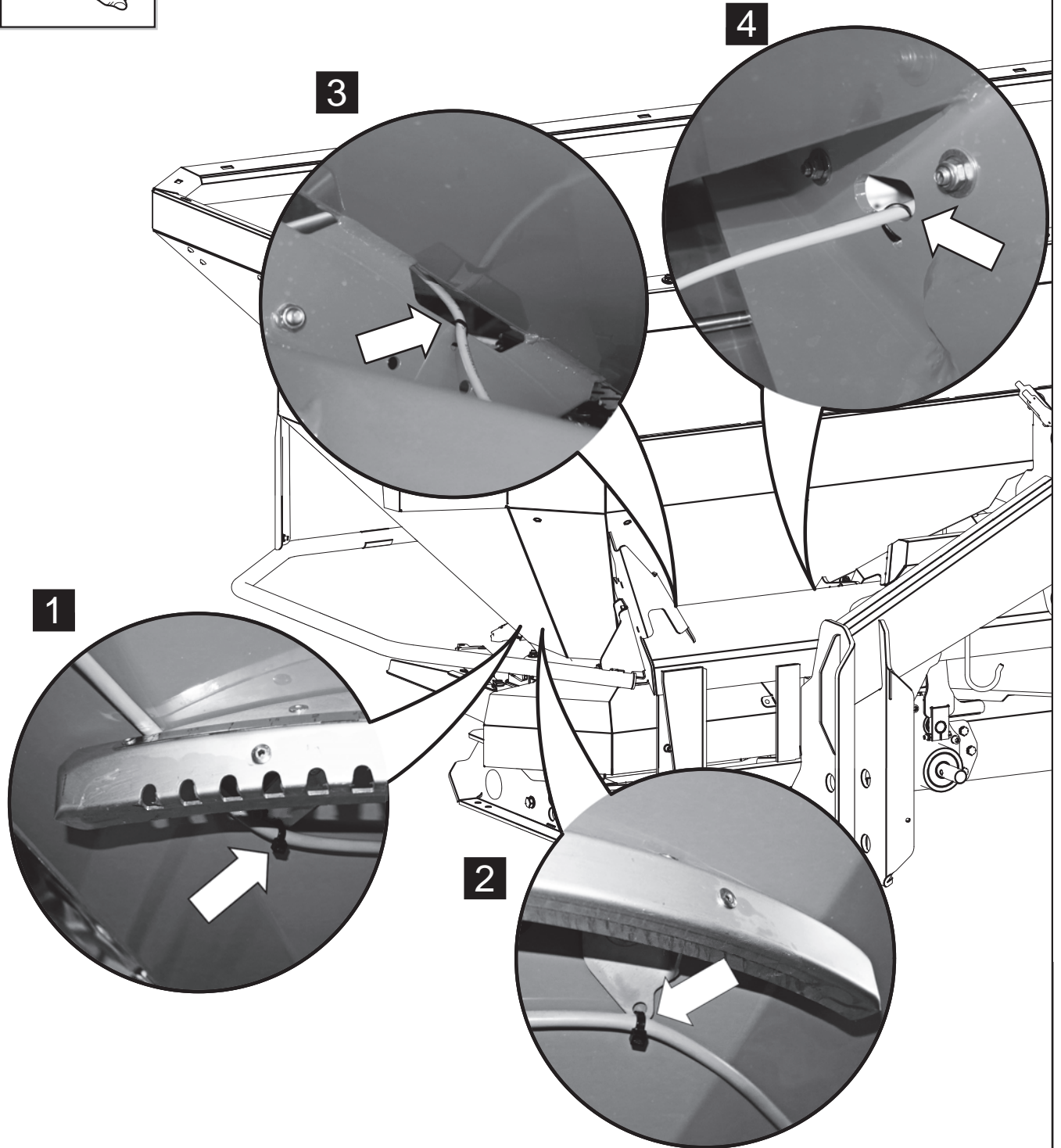
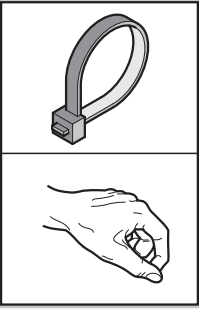

11a

BLW 50.2

AXIS 50 H EMC / H EMC+W

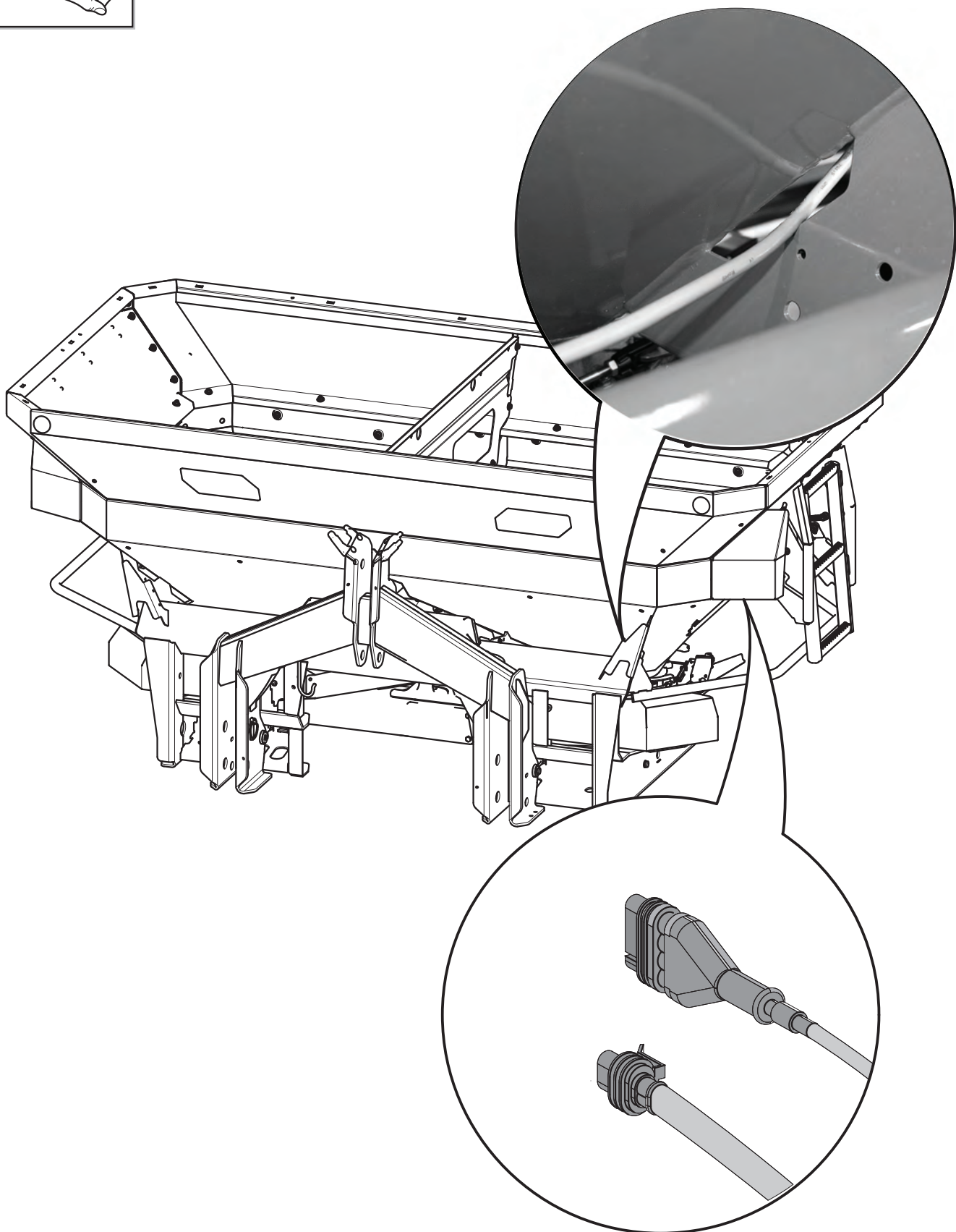

11b BLW 50.2 **AXIS 50 W**

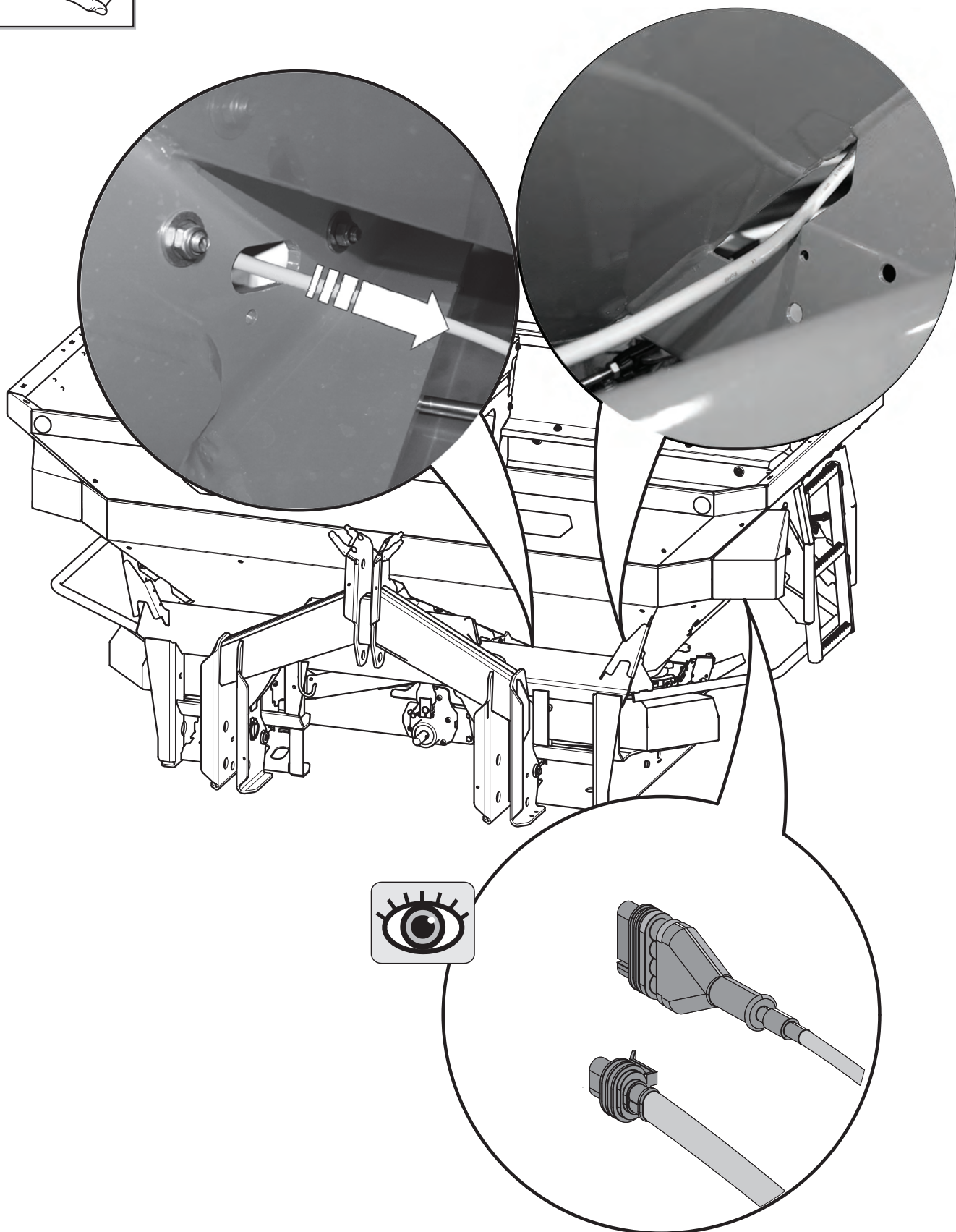



11c

BLW 50.2

AXIS 50 D

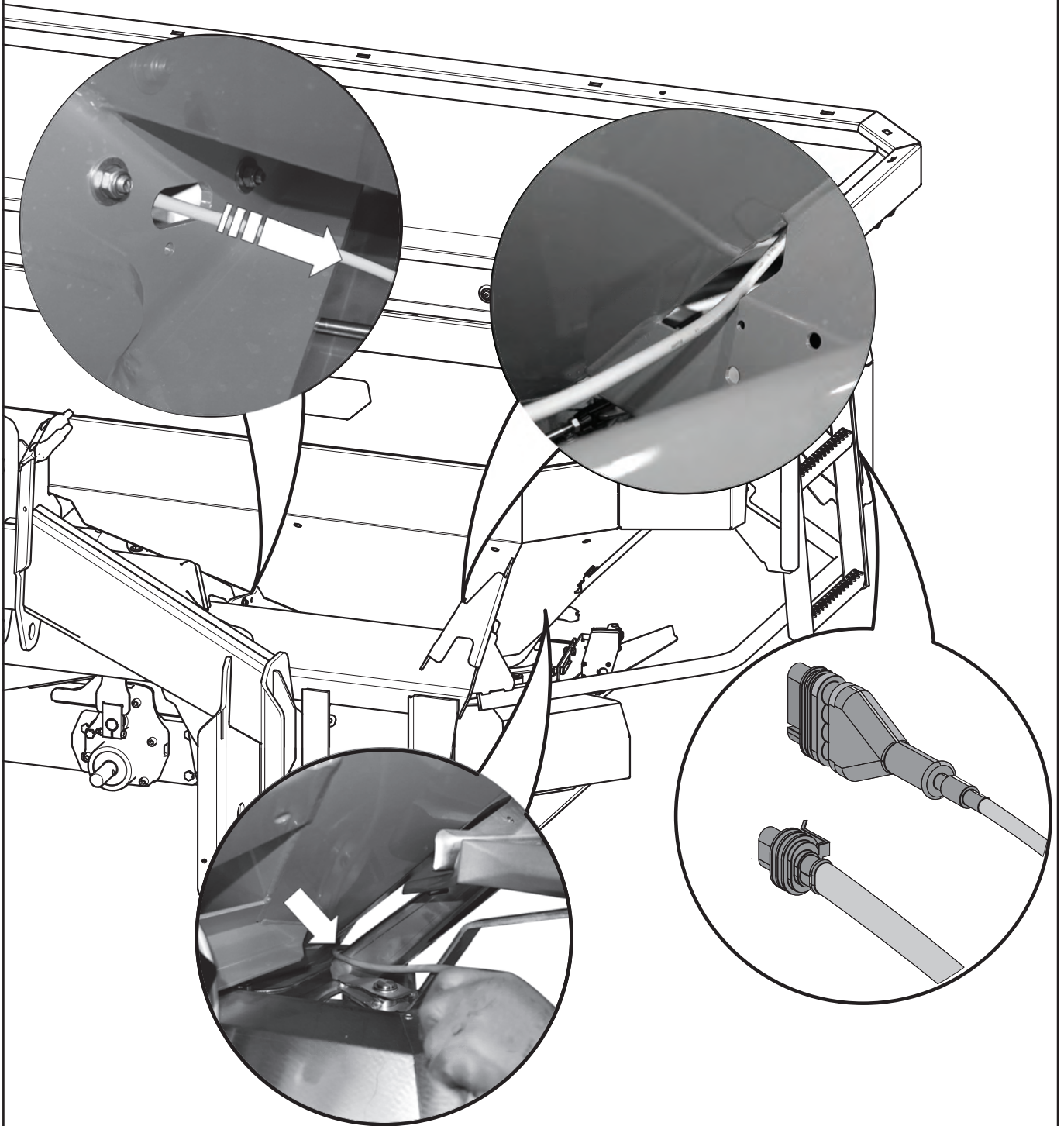
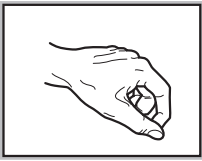

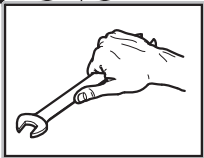
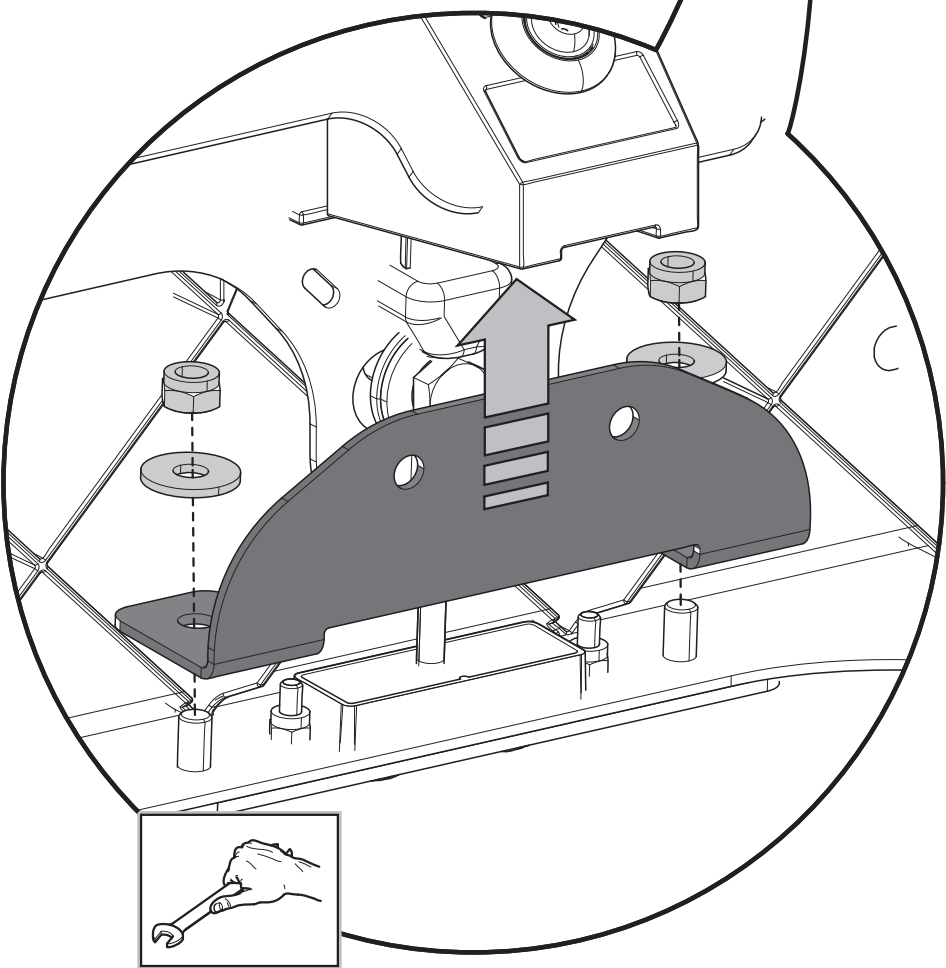
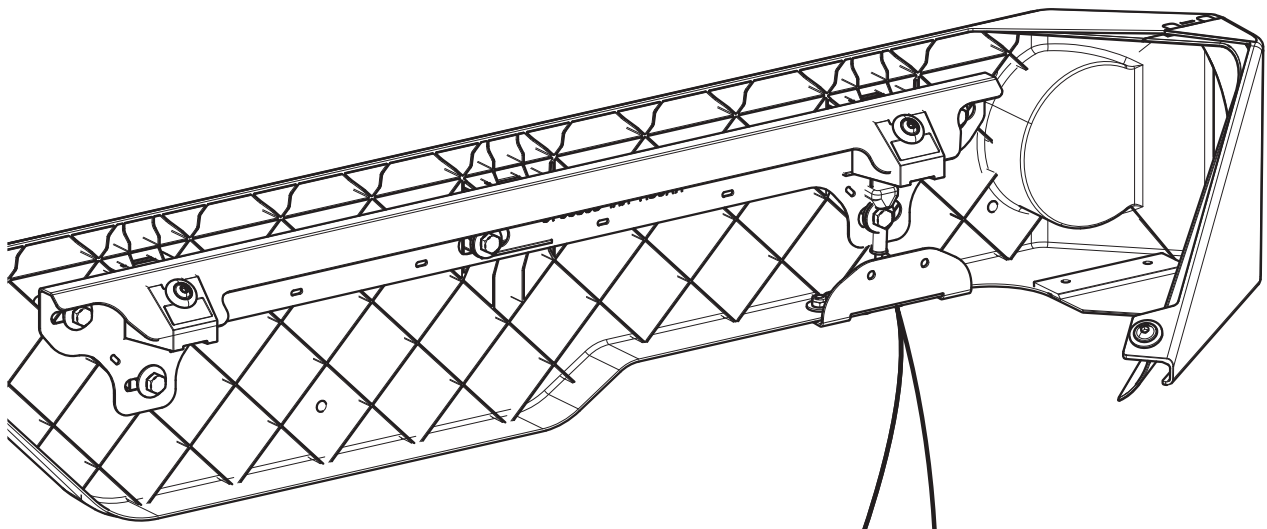



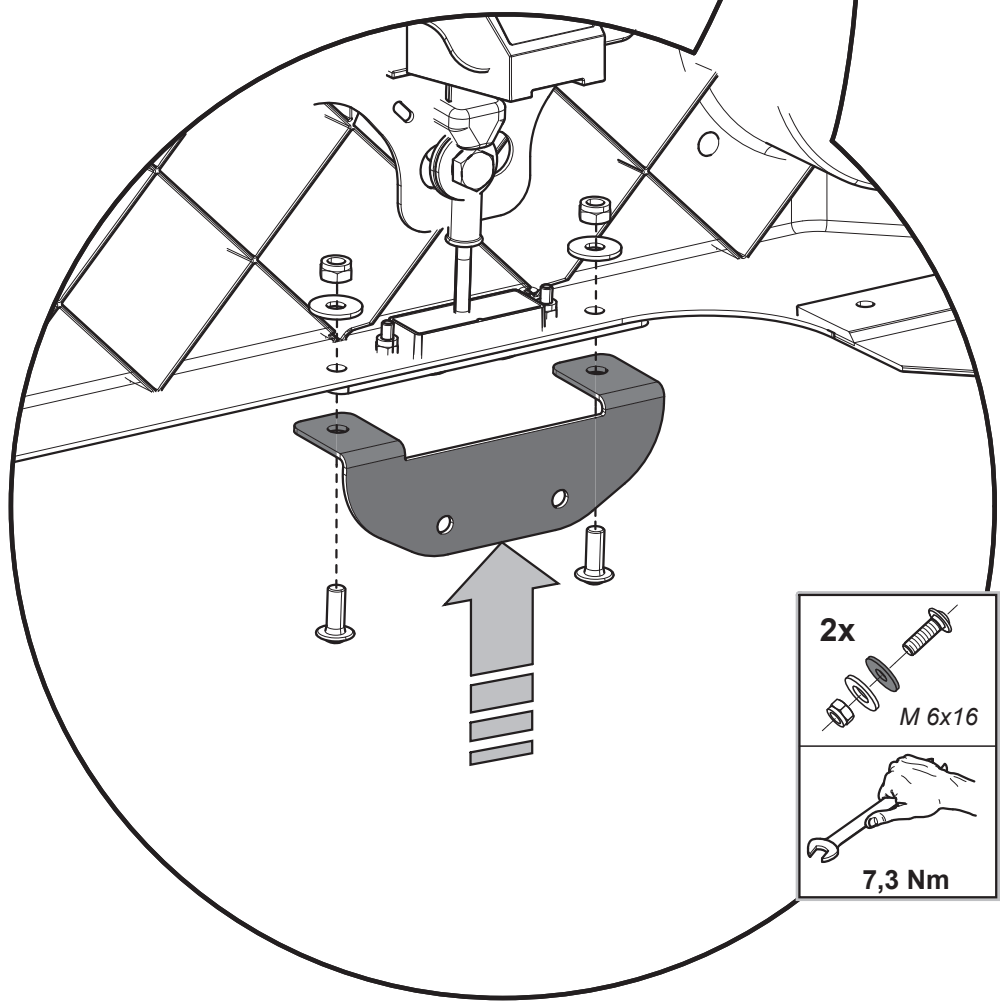
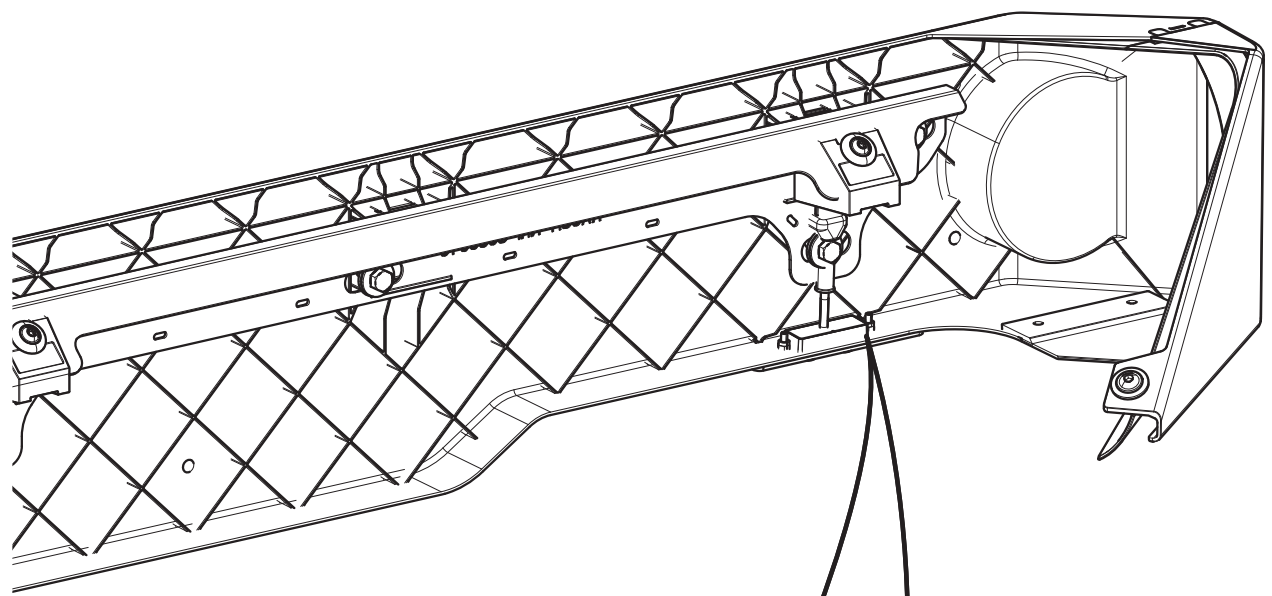

13 BLW 50.2 **AXIS 50**

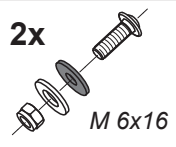

2x



M 6x16



7,3 Nm



14 BLW 50.2 **AXIS 50**

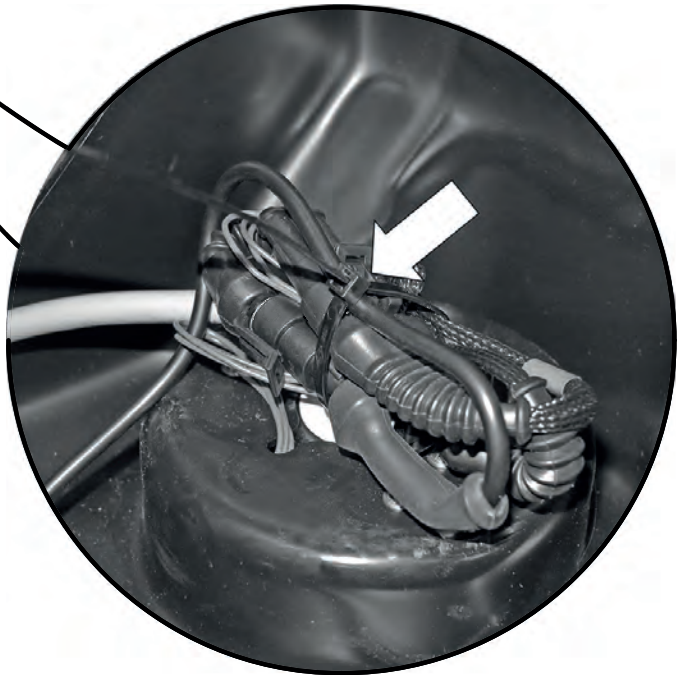
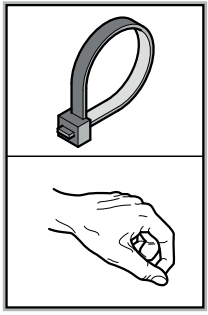
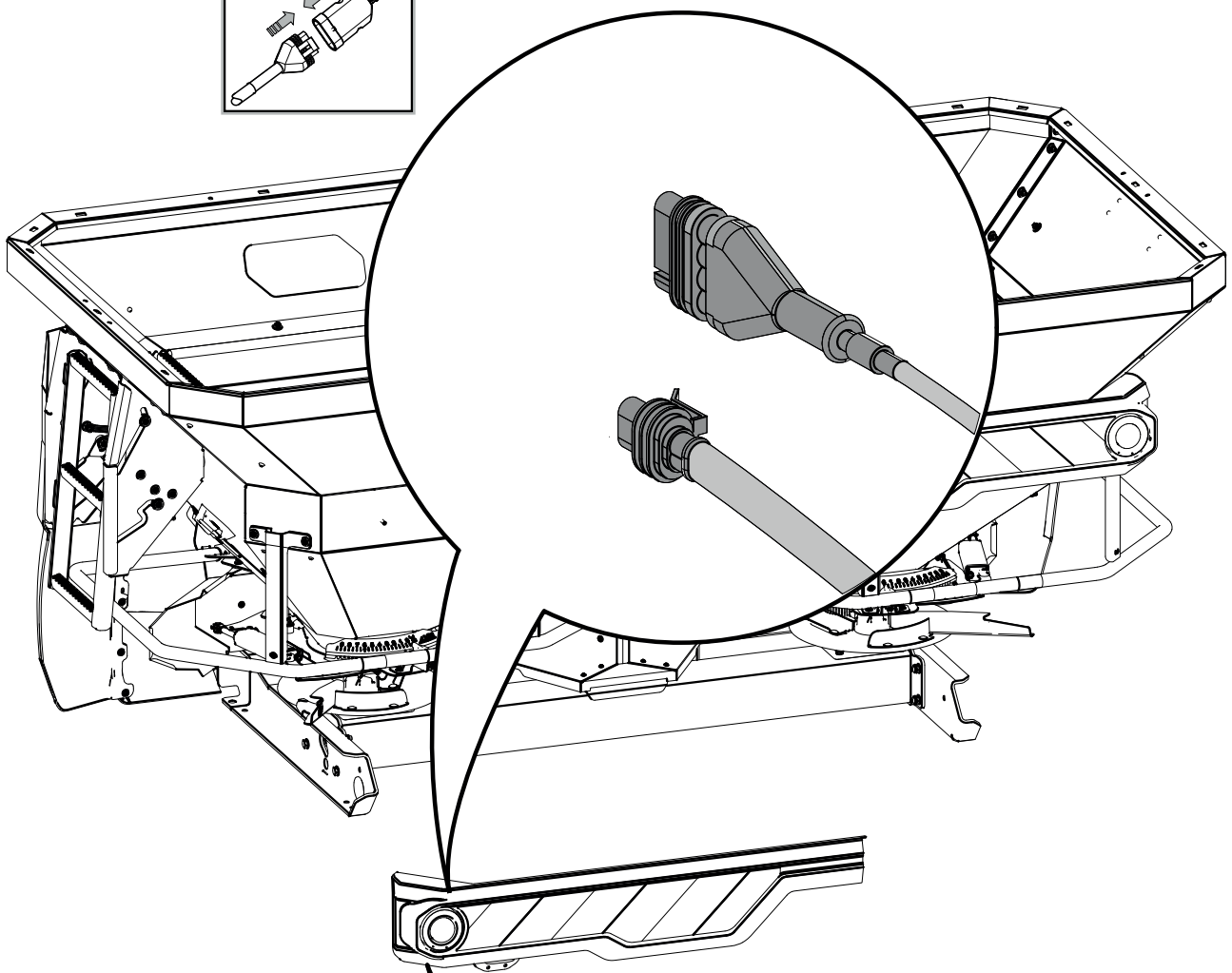
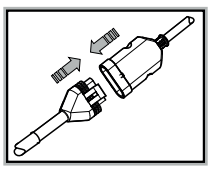



15 BLW 50.2 **AXIS 50**

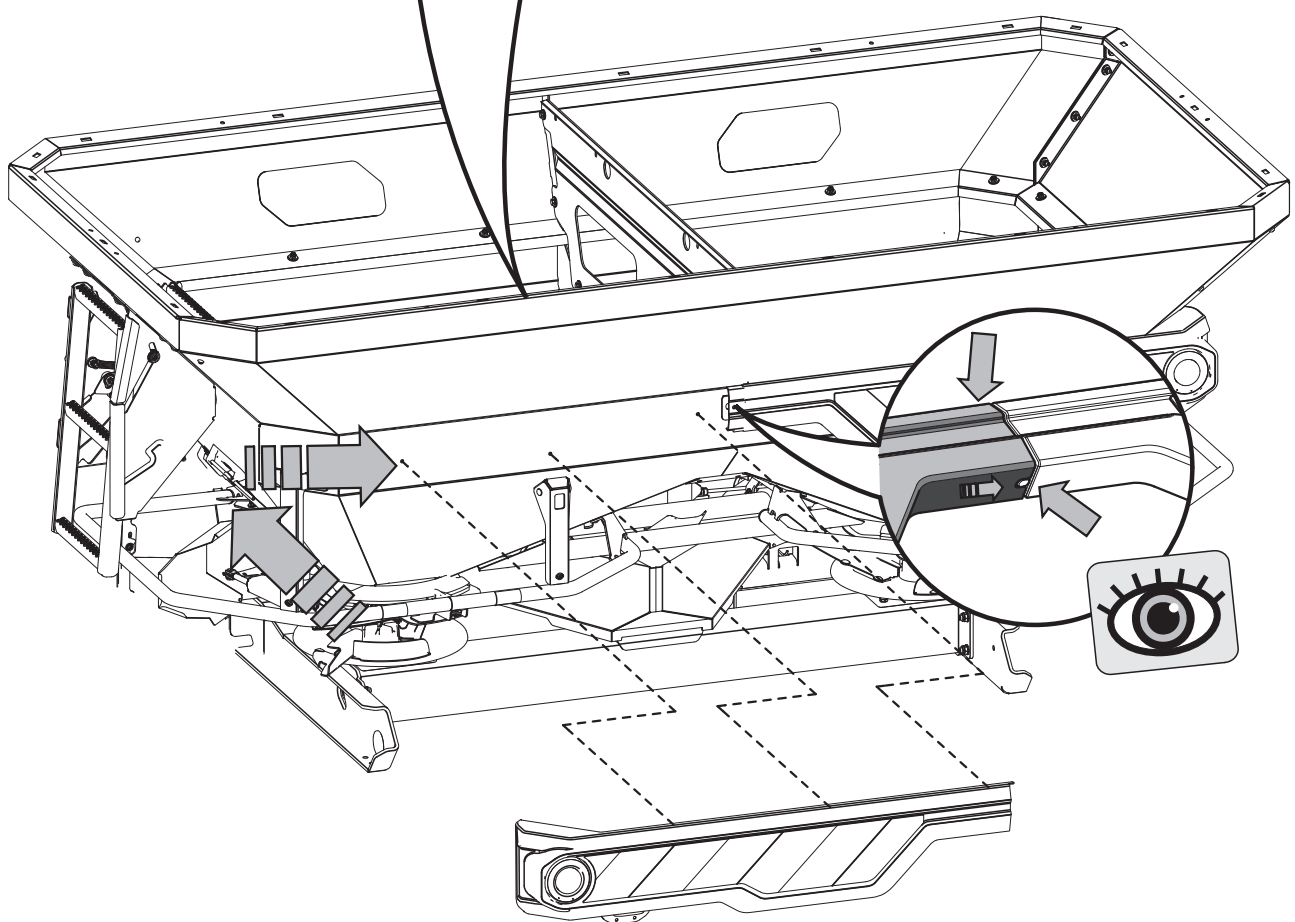
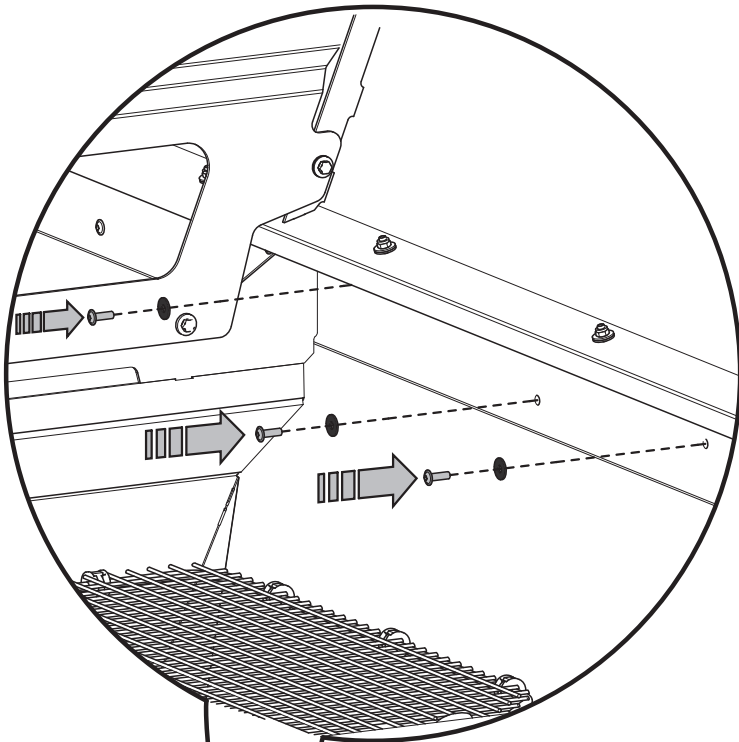
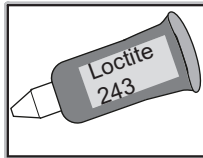
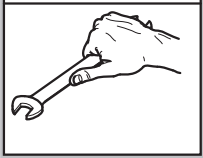
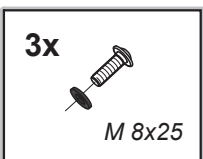



16 BLW 50.2 **AXIS 50**

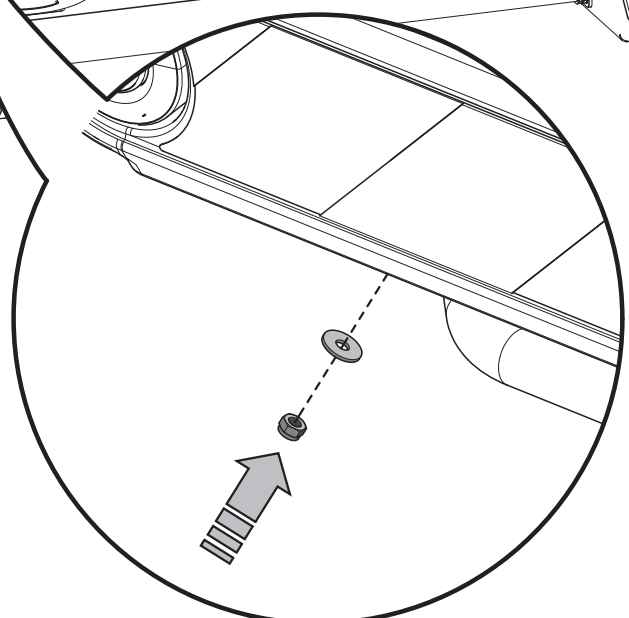
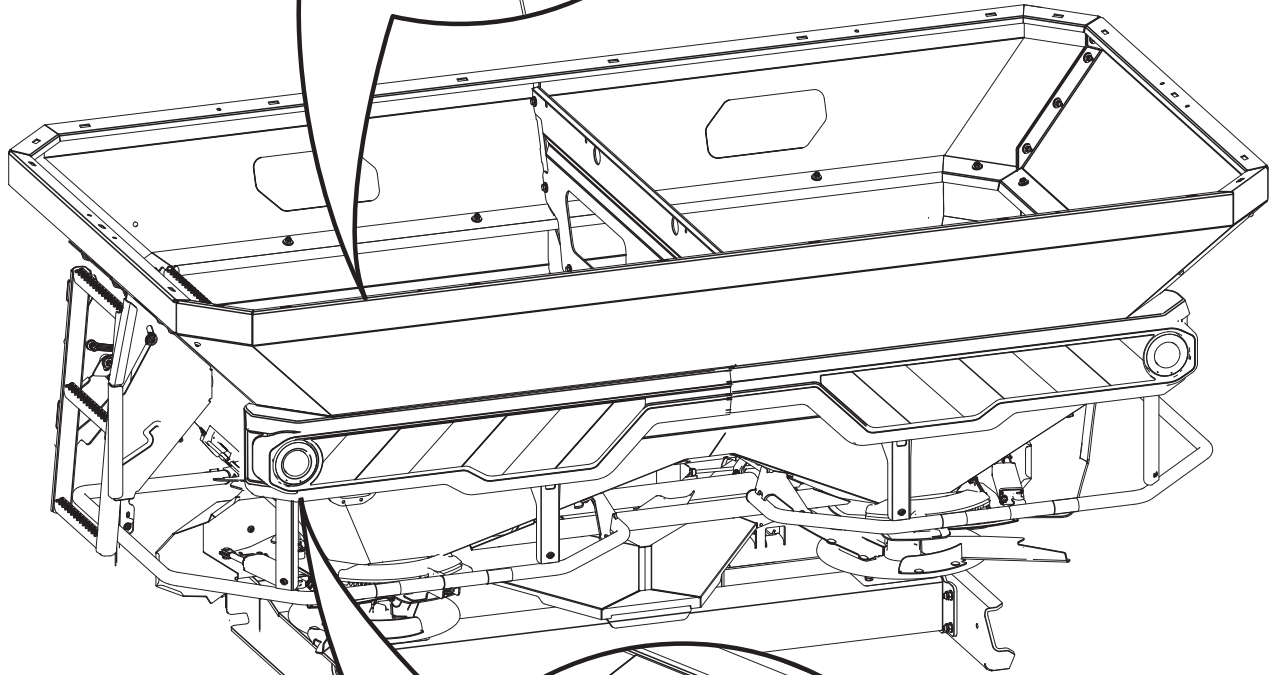
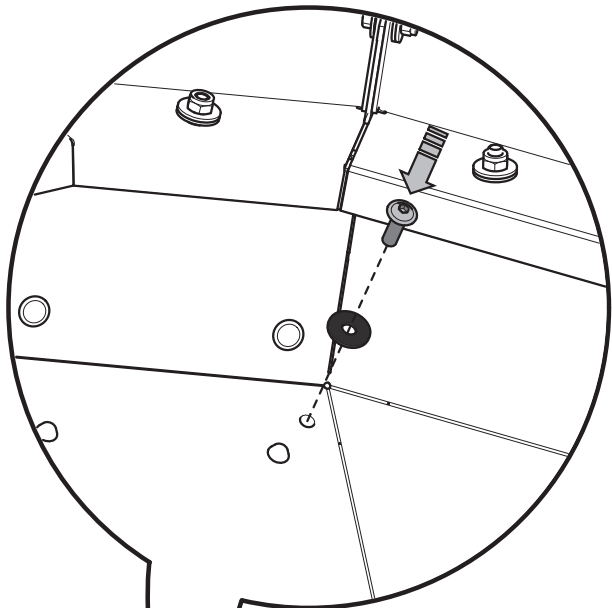
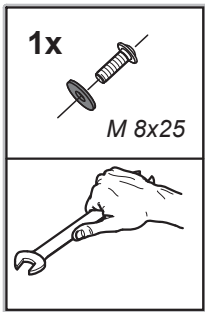

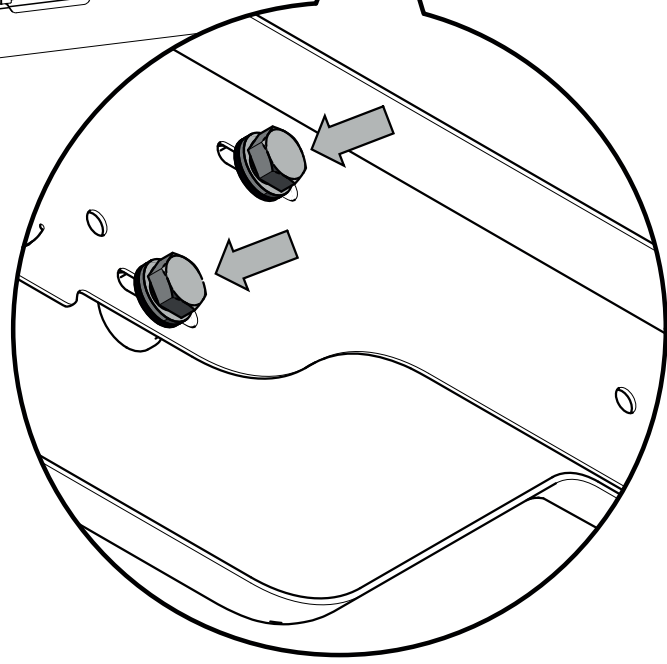
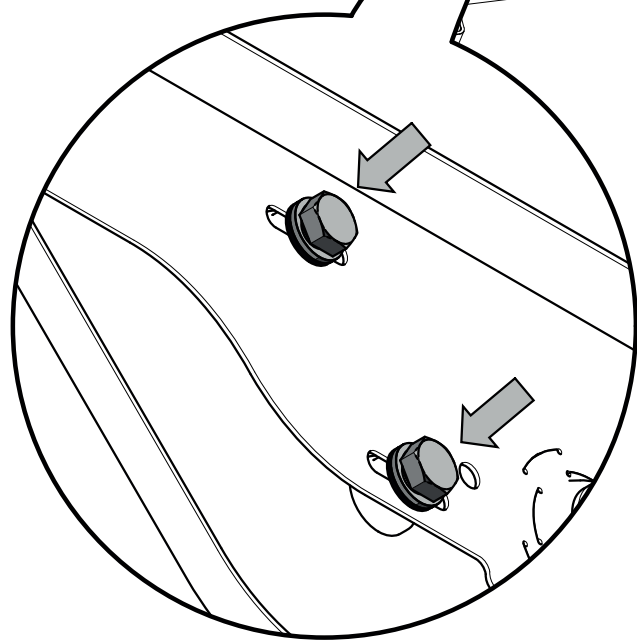
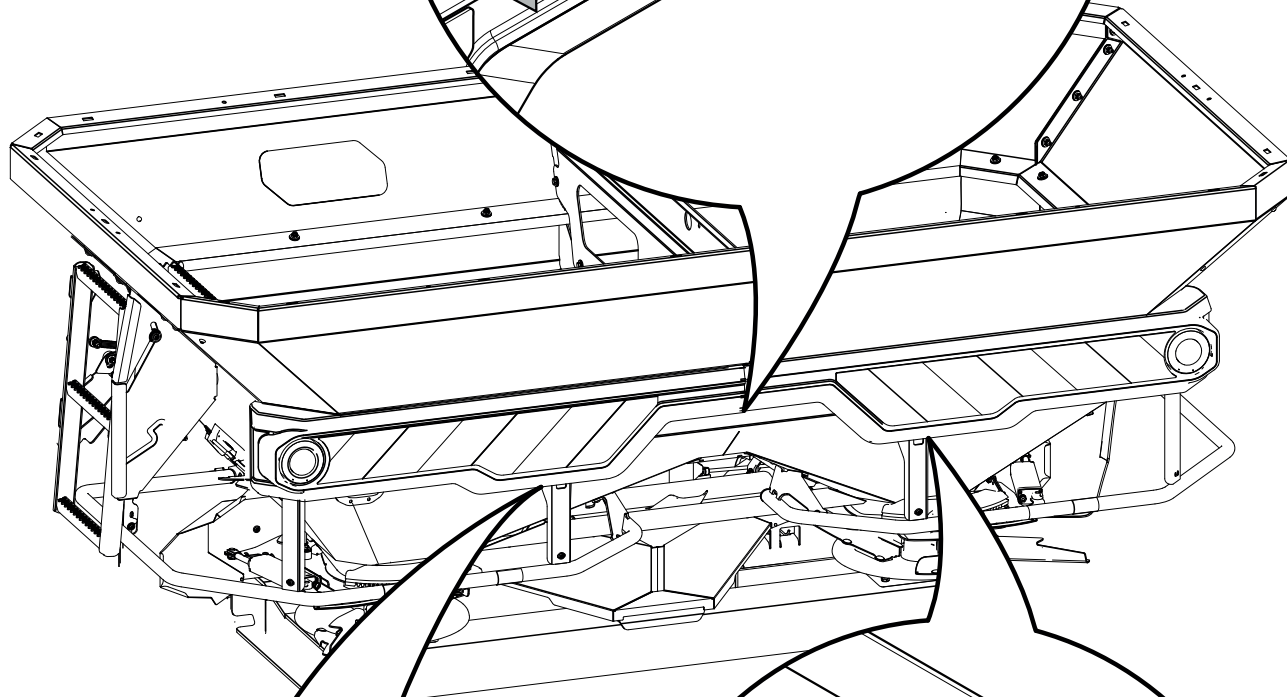
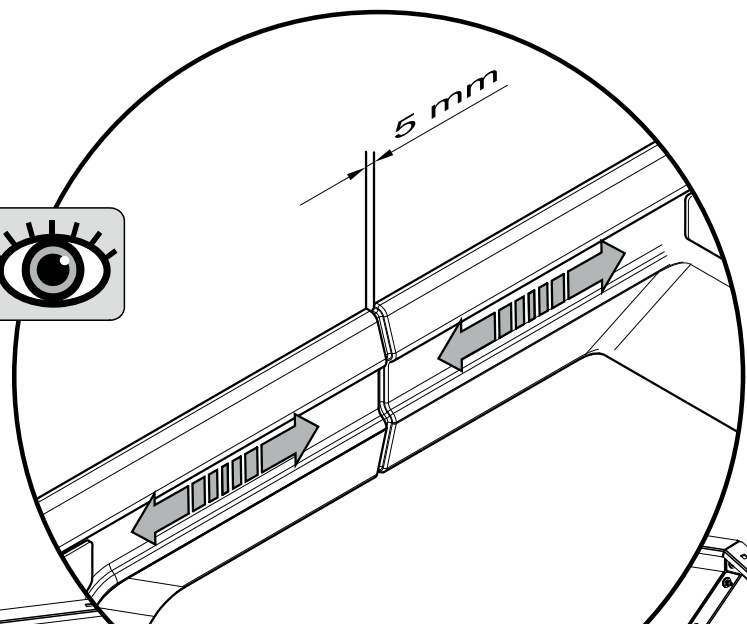
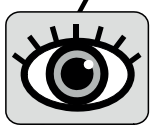
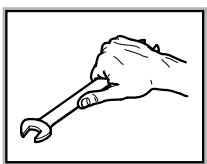
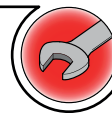

18 BLW 50.2 **AXIS 50**

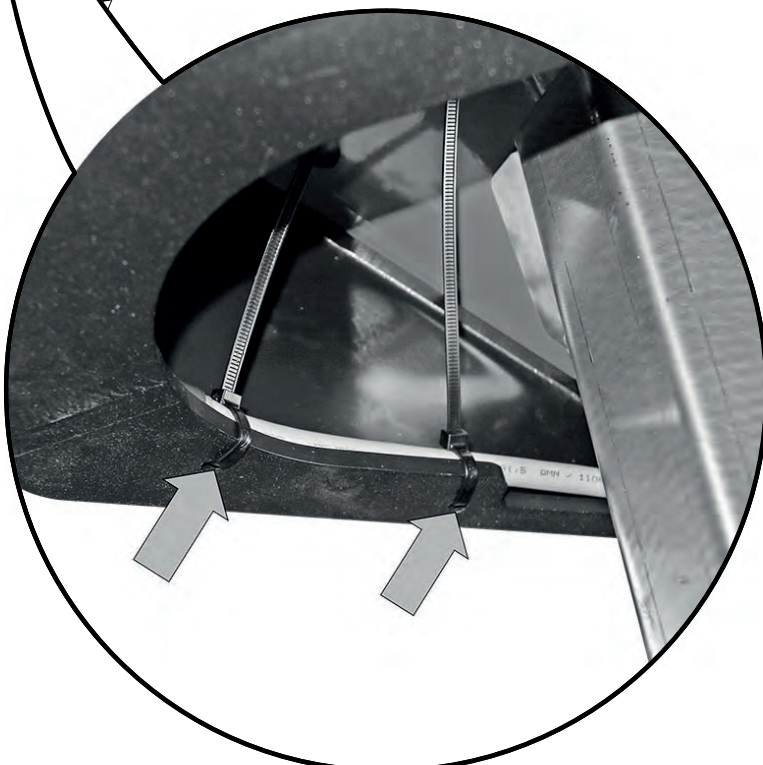
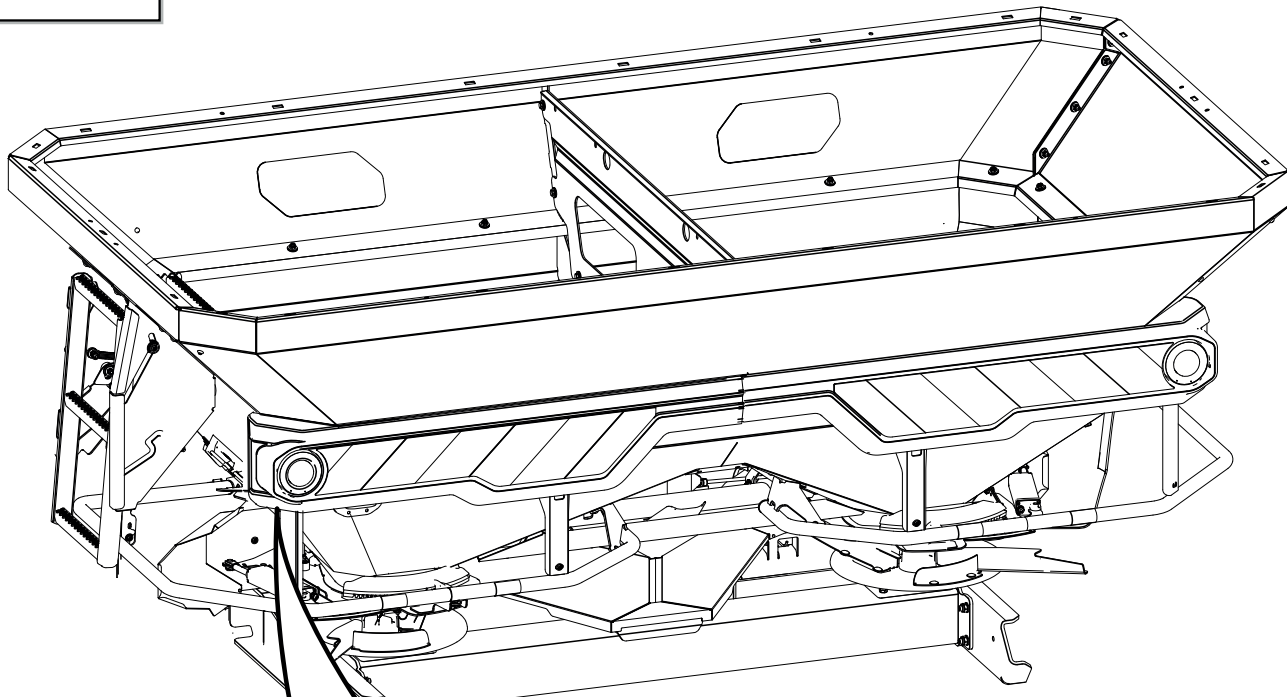
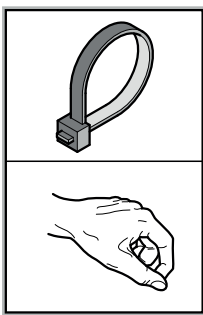



19a

BLW 50.2

AXIS 50 H EMC / H EMC+W

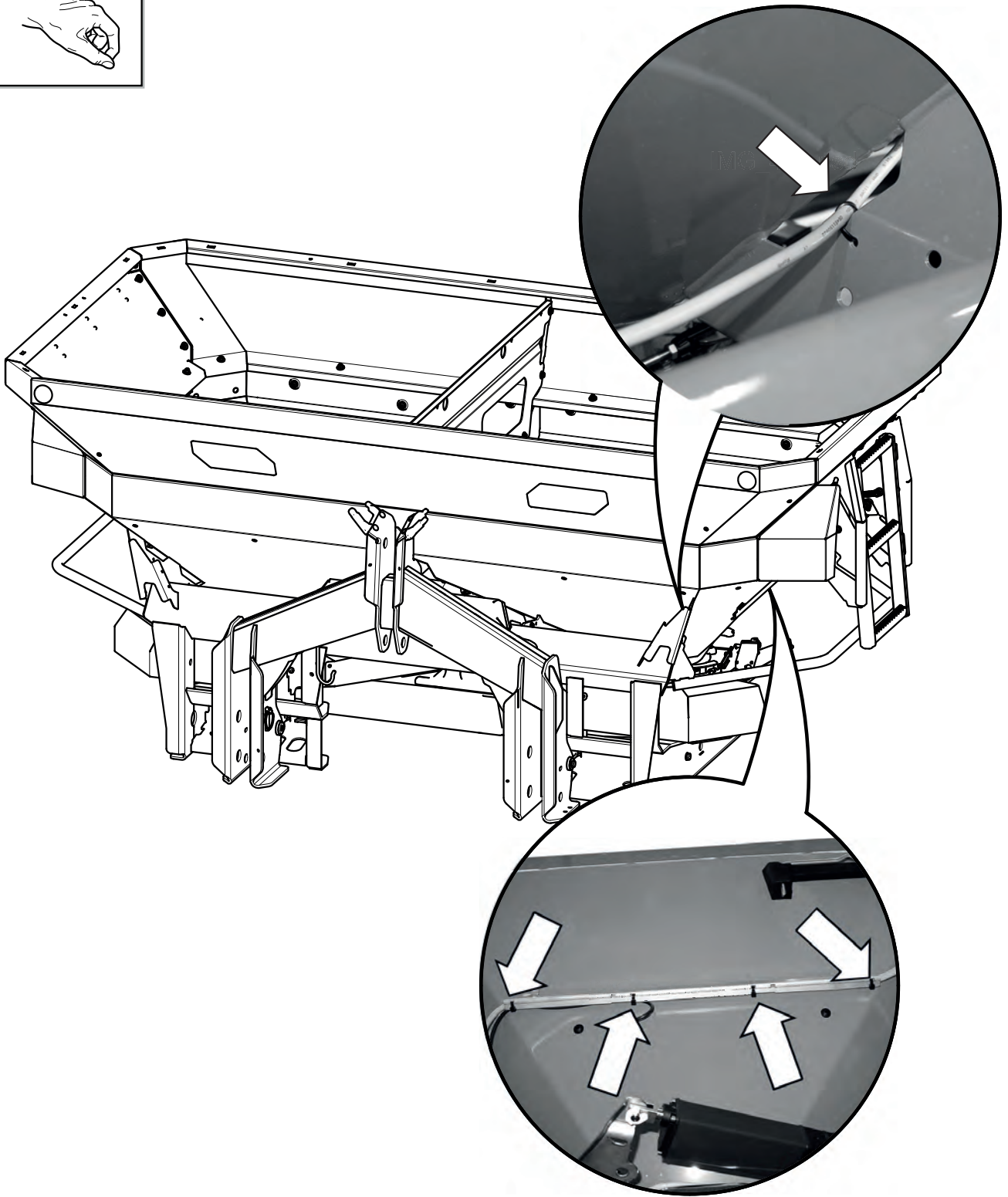
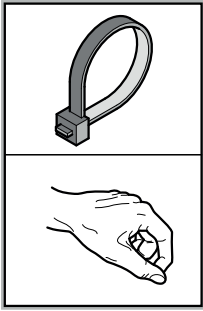

19b BLW 50.2 **AXIS 50 W**

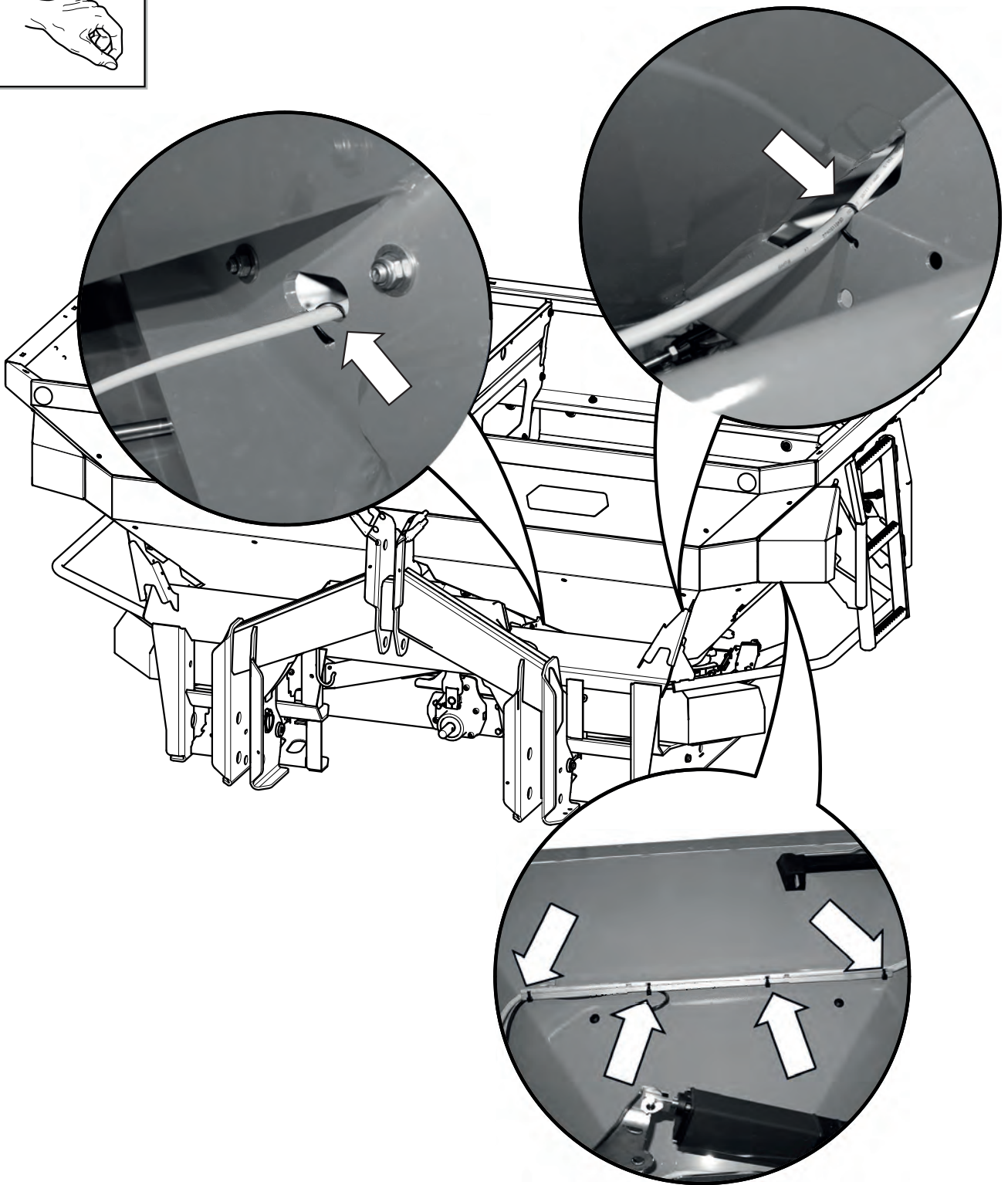
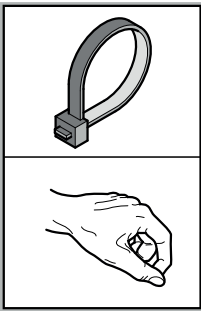



19c BLW 50.2 **AXIS 50 D**

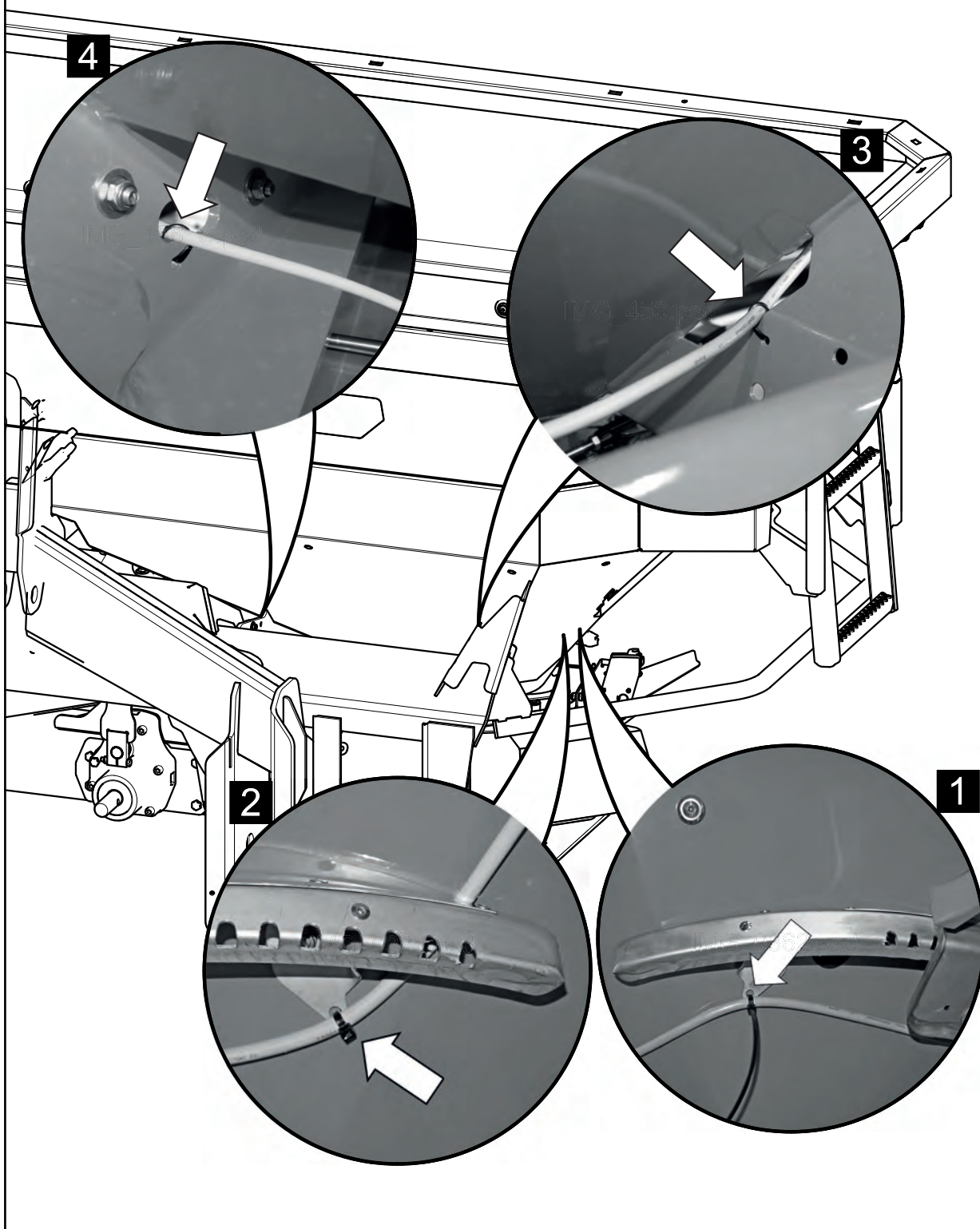
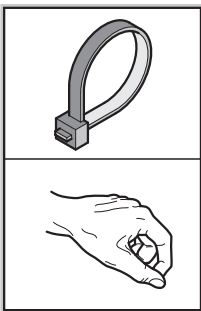

20a

BLW 50.2

AXIS 50 H EMC / H EMC+W

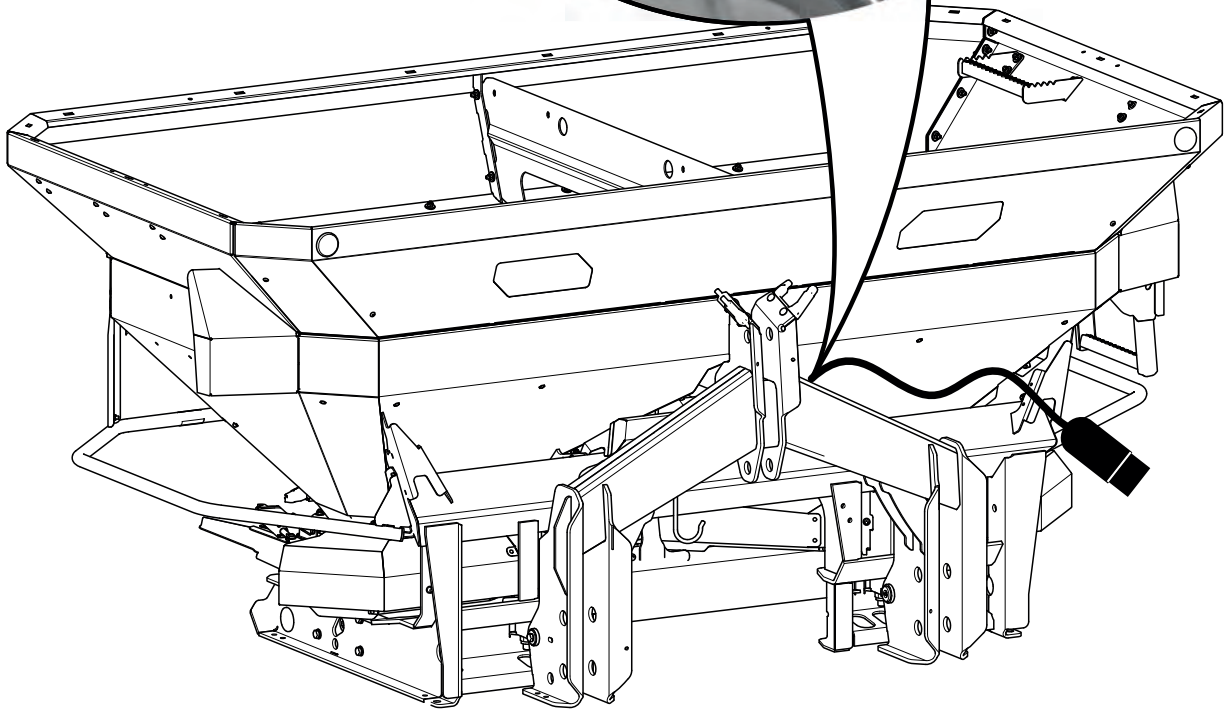
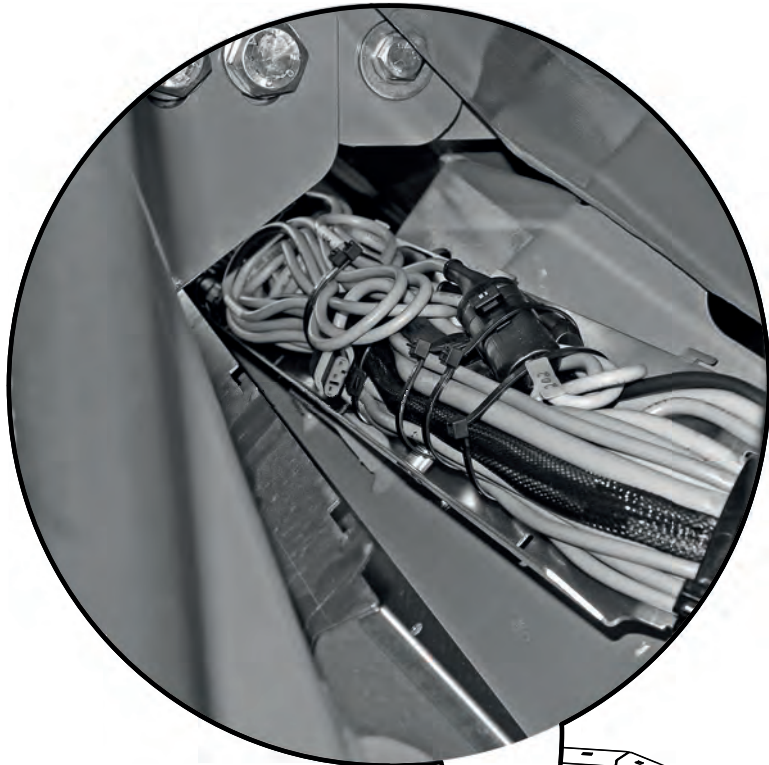
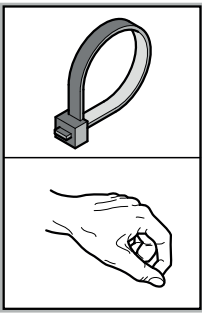

20b BLW 50.2 **AXIS 50 W**

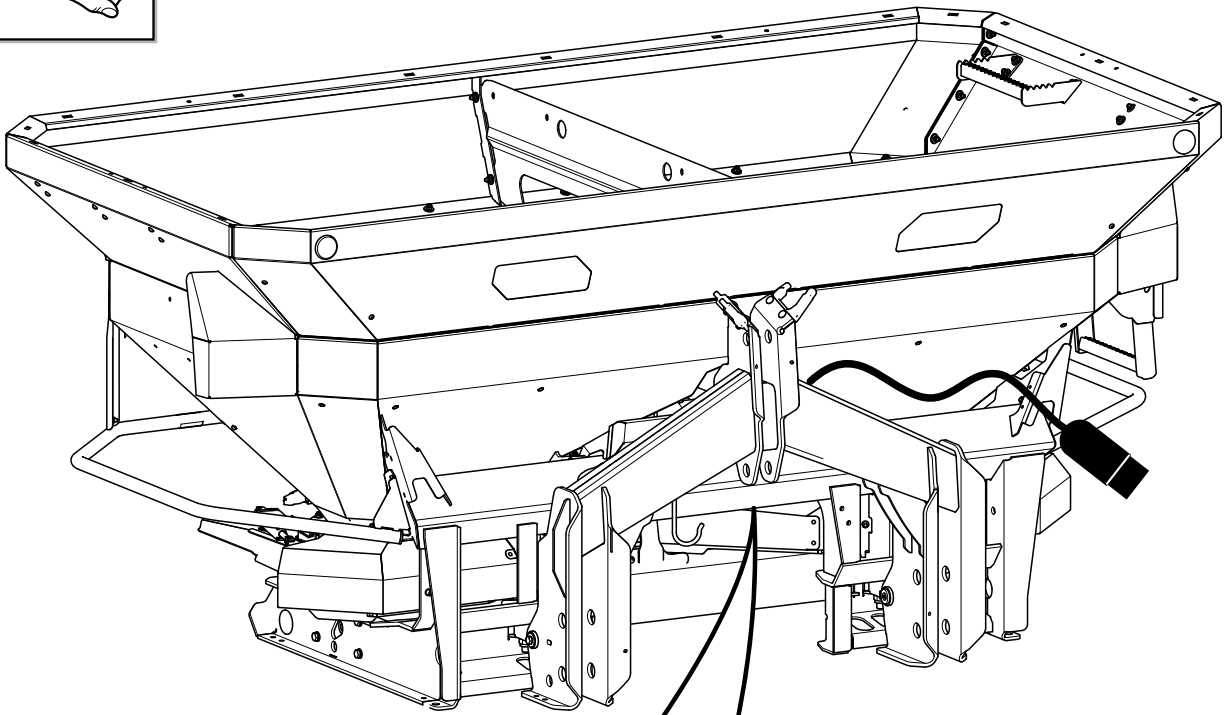
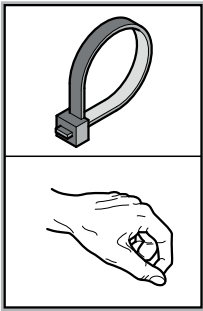



18c

BLW 50.2

AXIS 50 D

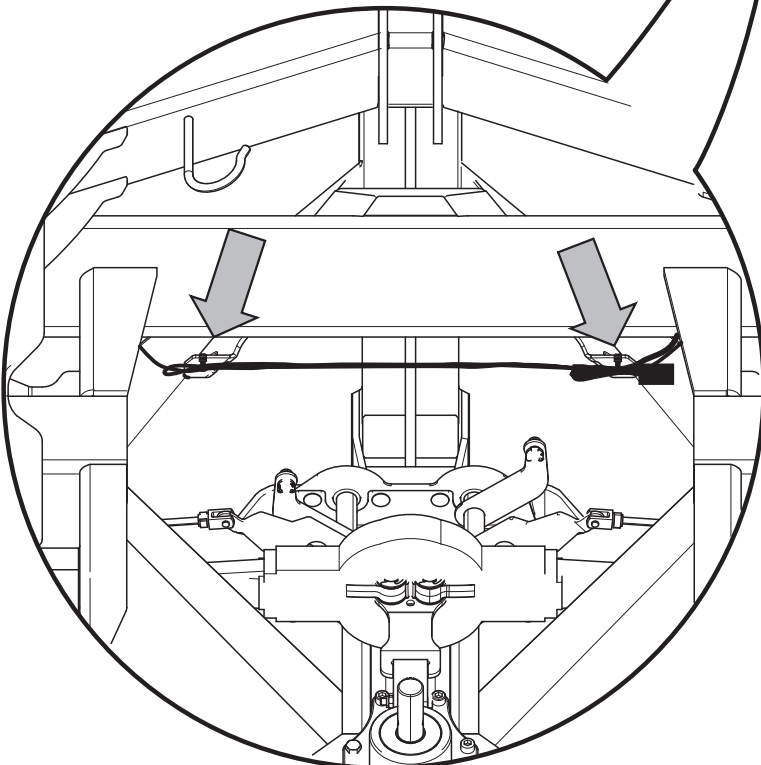
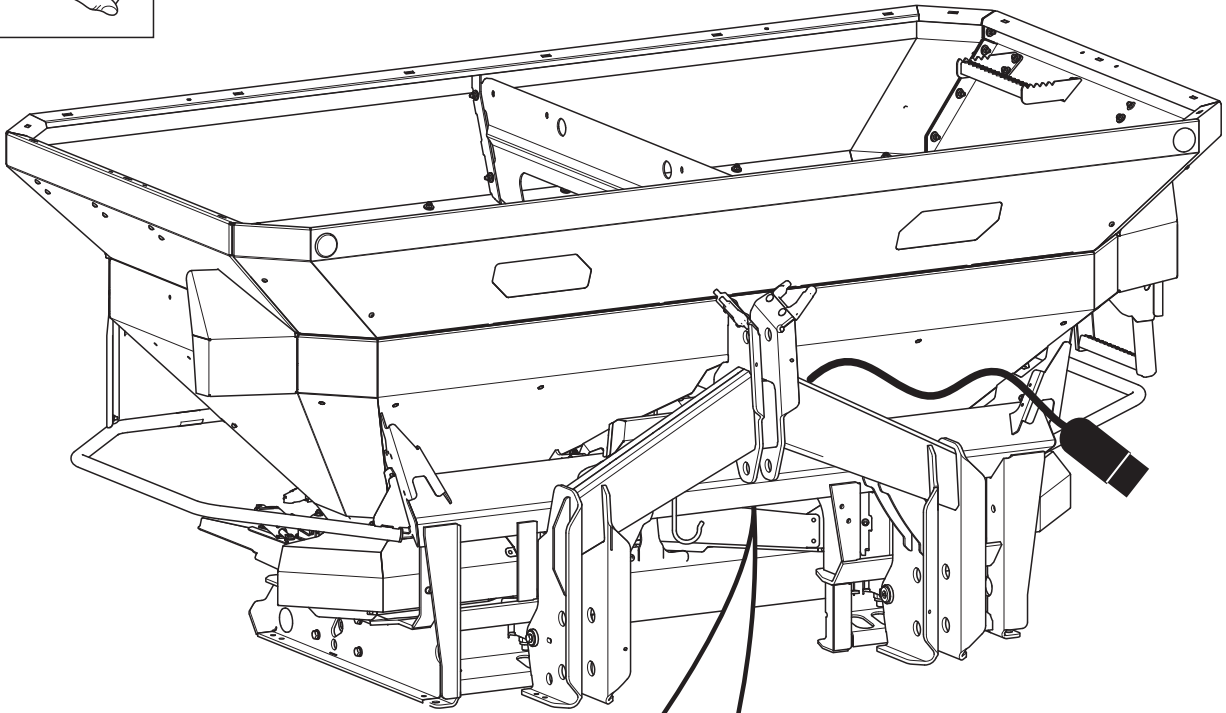
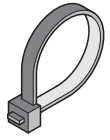
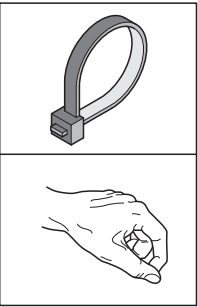

(21)

BLW 50.2

AXIS 50 H EMC / H EMC+W



2x

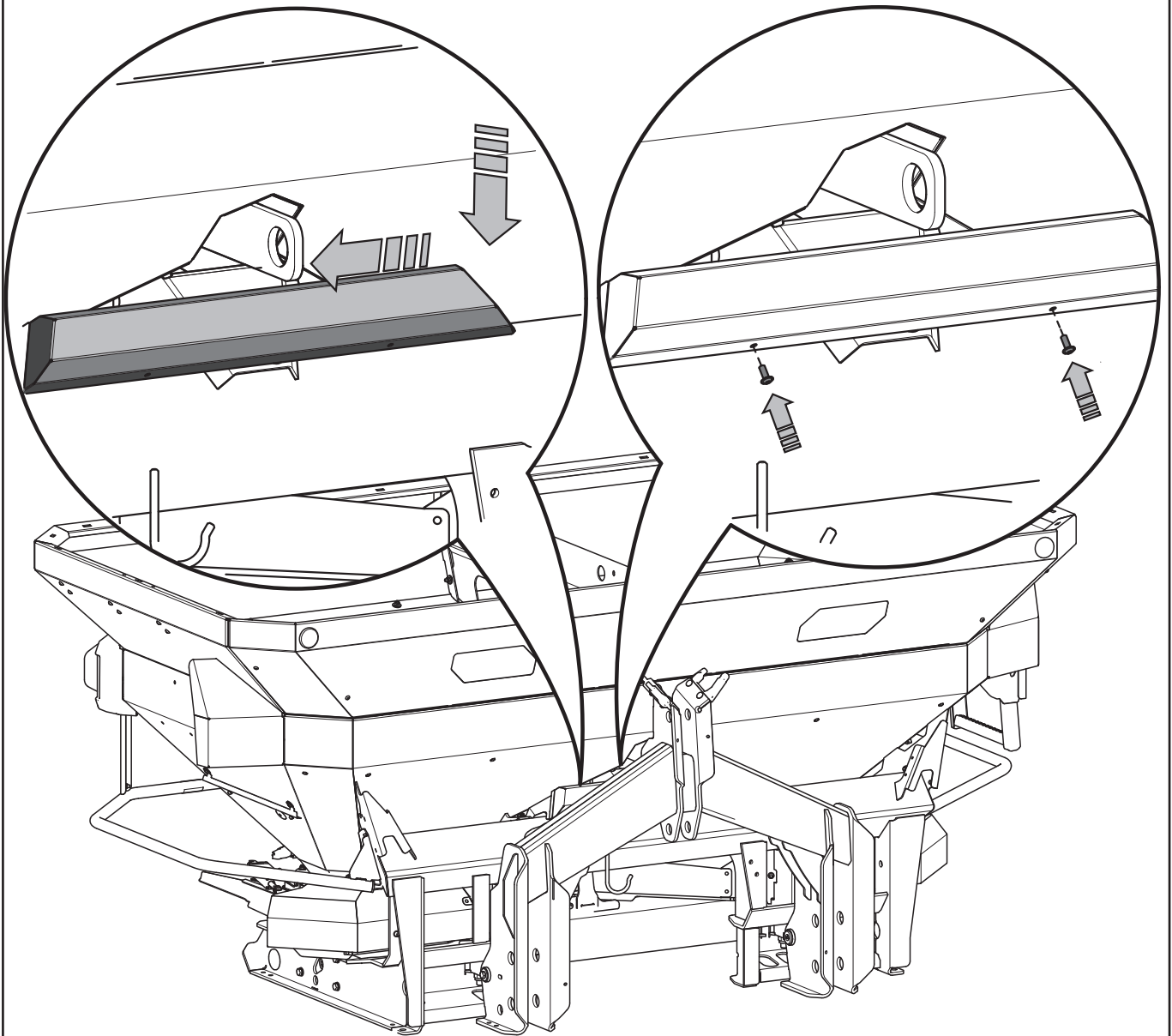
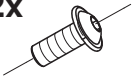

22a

BLW 50.2

AXIS 50



3x



M 8x25



max. 18 Nm

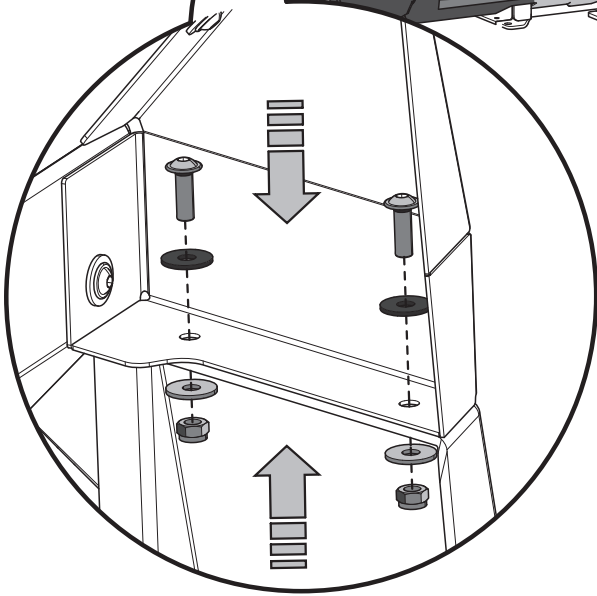
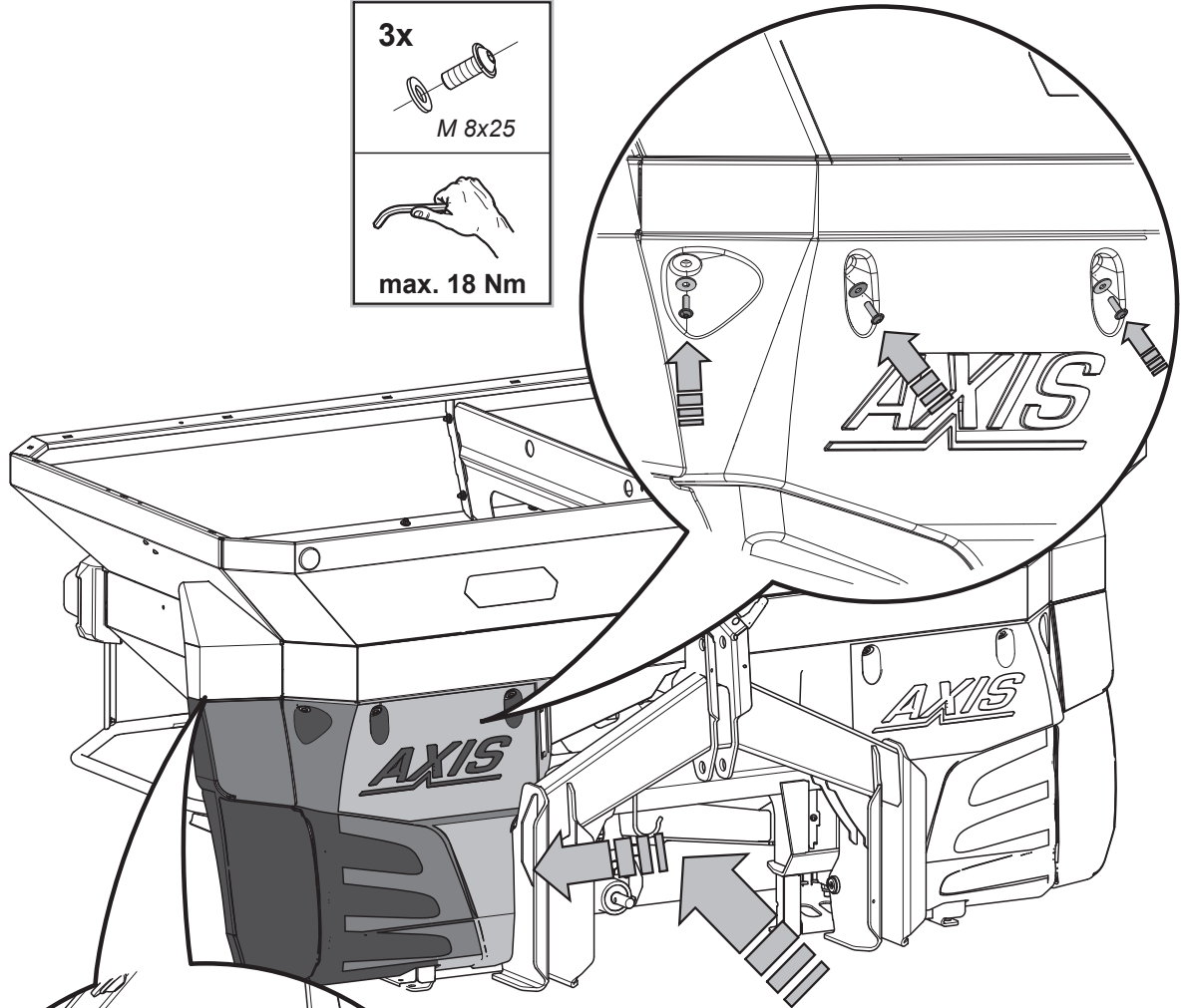

2x

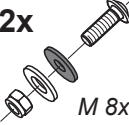

M 8x25



max. 18 Nm

22b

BLW 50.2

AXIS 50

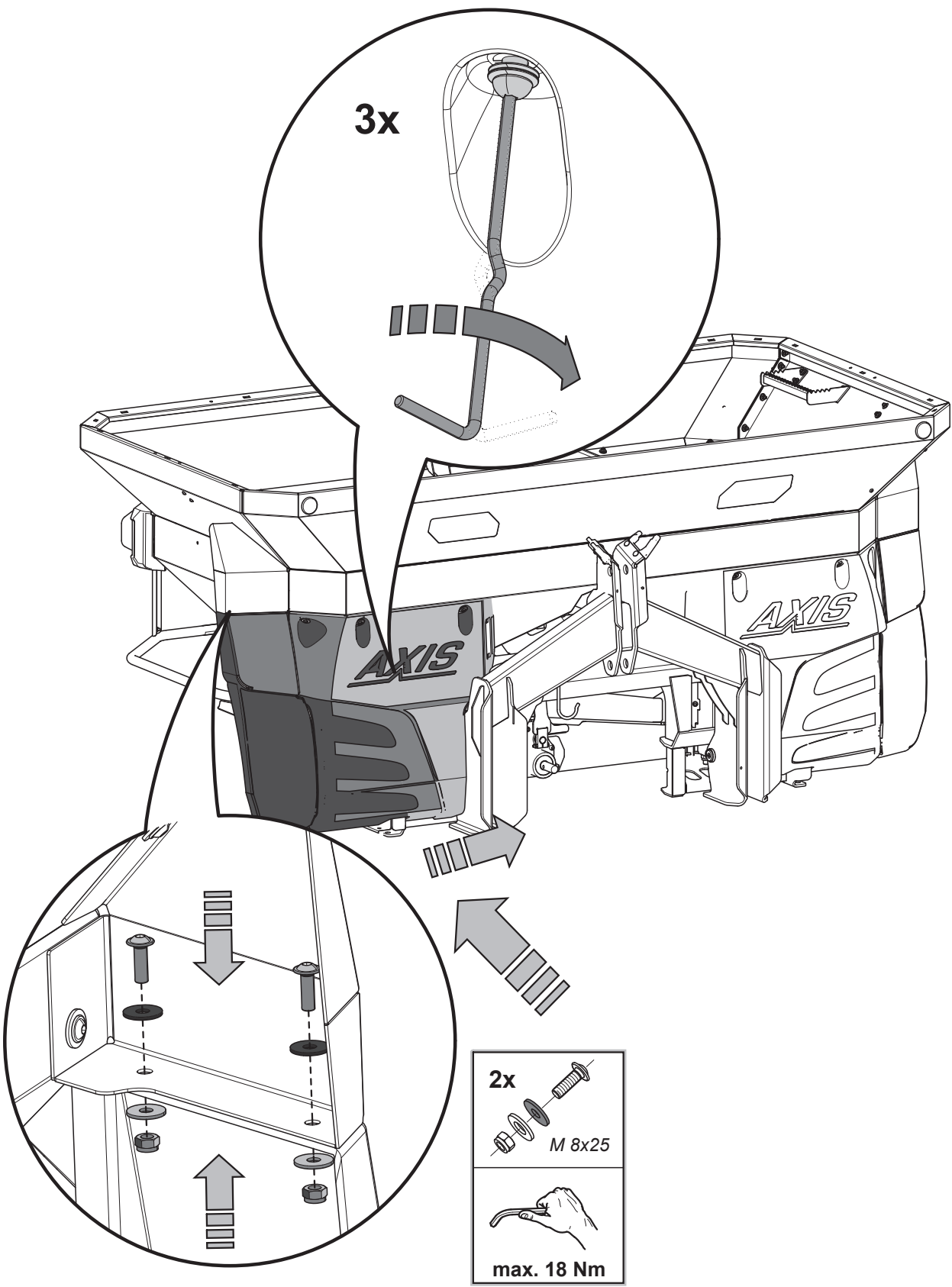

23a

BLW 50.2

AXIS 50

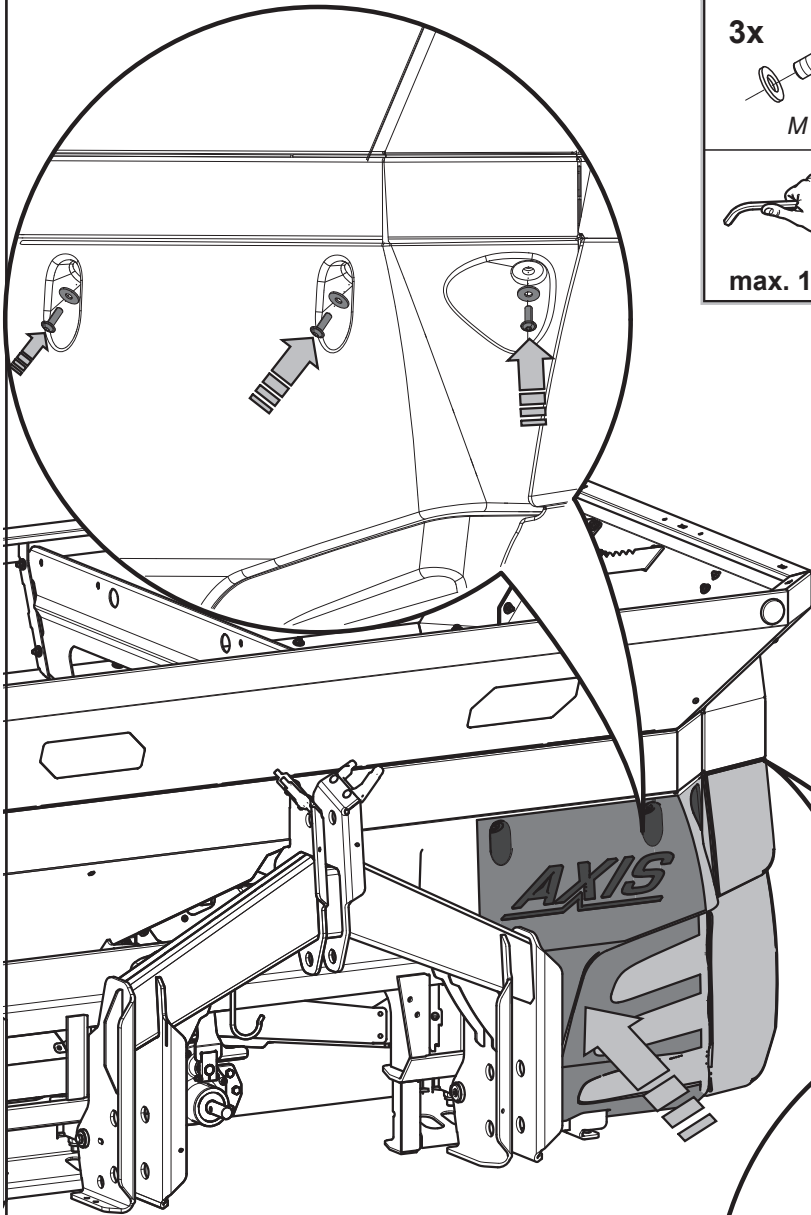

3x



M 8x25



max. 18 Nm

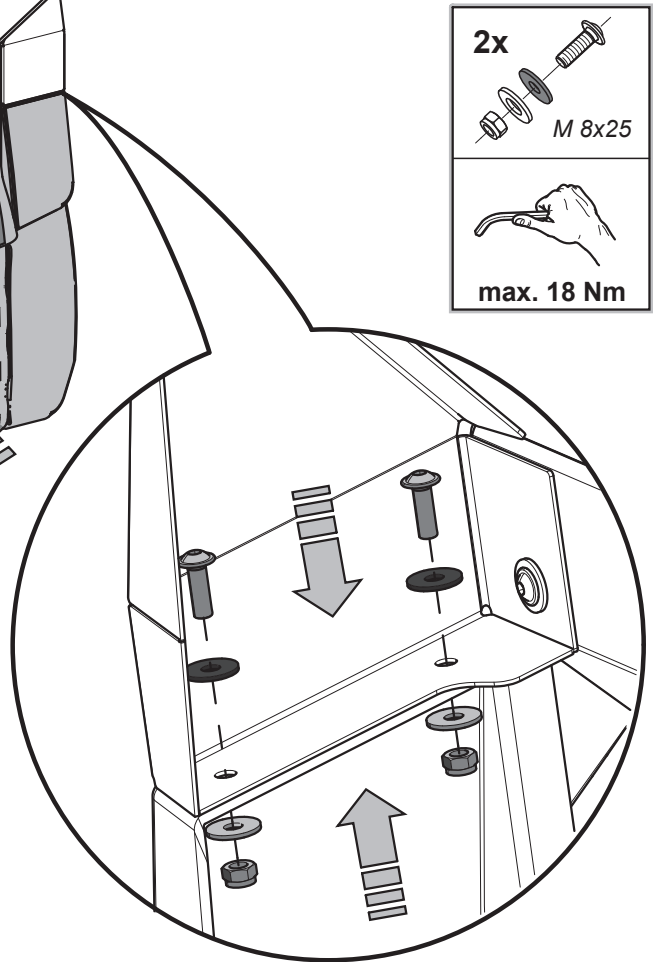

2x

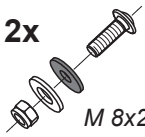

M 8x25



max. 18 Nm

23b

BLW 50.2

AXIS 50

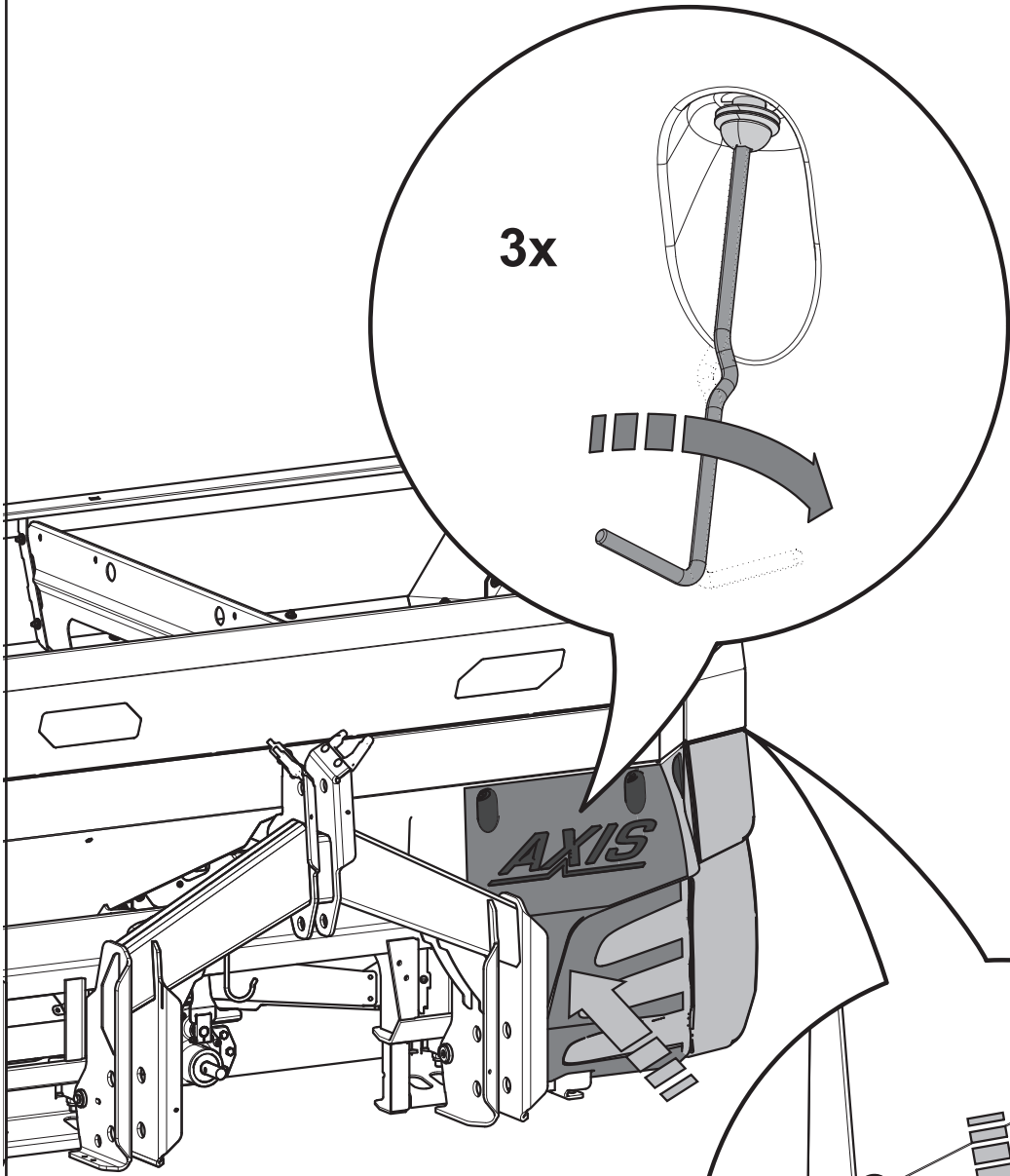

2x	
	M 8x25
max. 18 Nm	

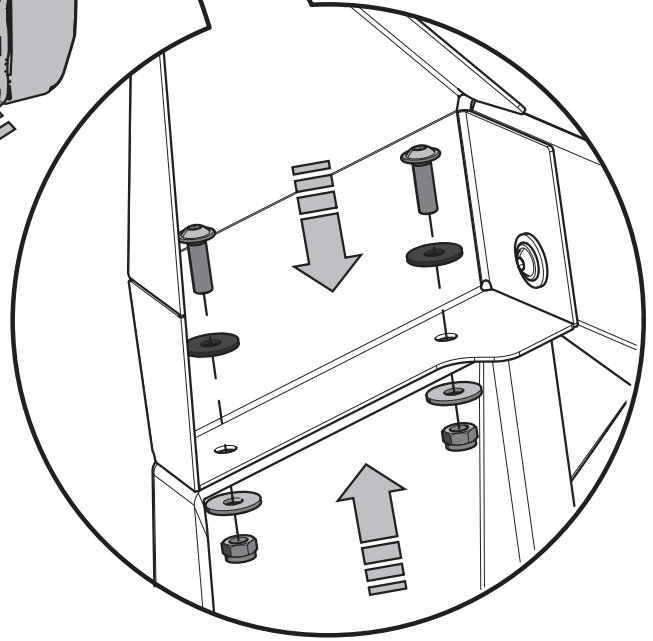

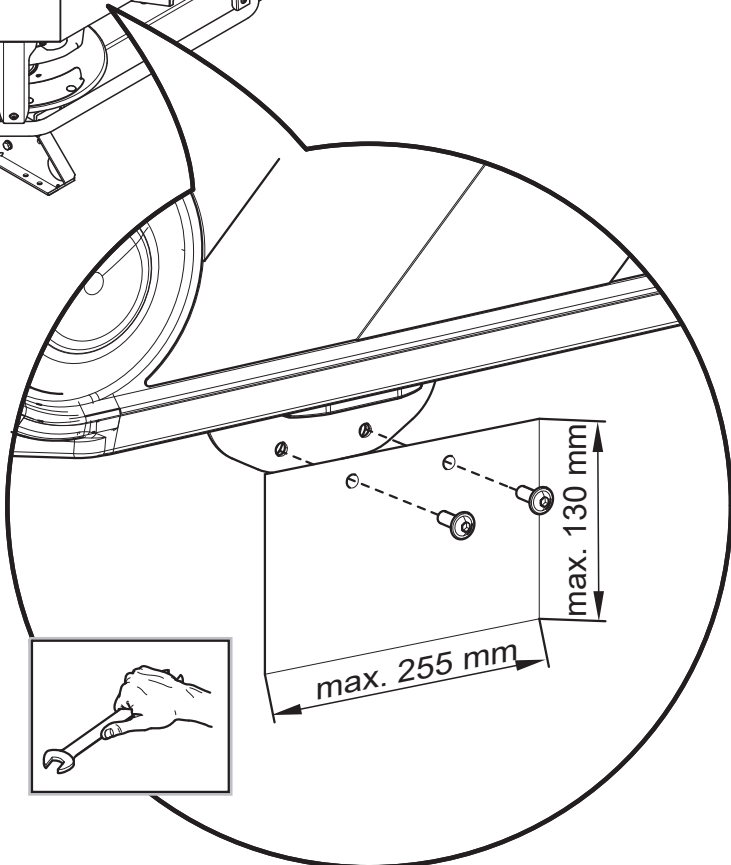
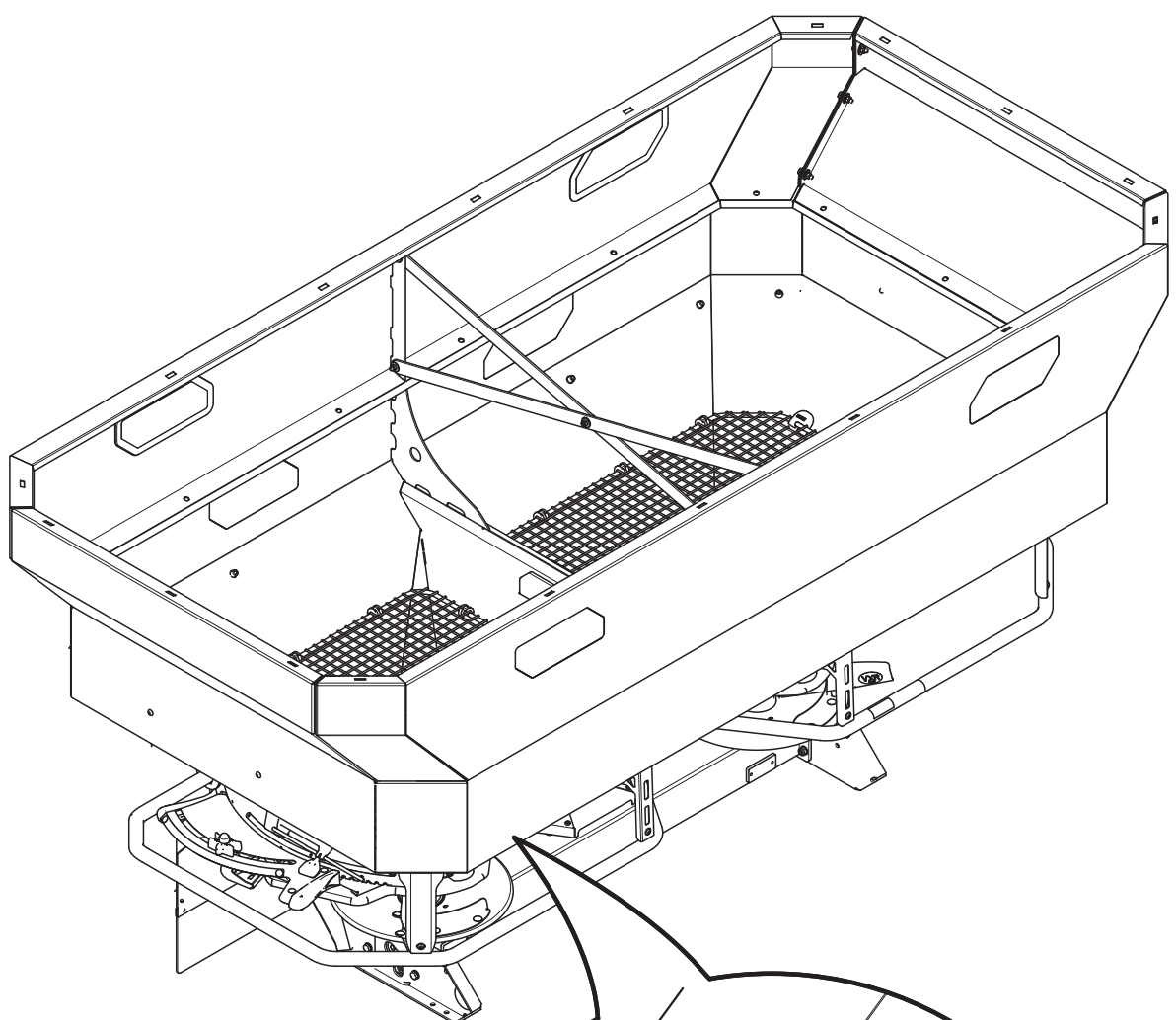



www.kuhn.com

KUHN SAS - B.P. 50060 - F - 67706 SAVERNE CEDEX (FRANCE)

KUHN-AUDUREAU SAS - B.P. 19 - F - 85260 LA COPECHAGNIERE (FRANCE)

KUHN-BLANCHARD SAS - 24, route de Nantes - F - 44680 CHEMERE (FRANCE)

KUHN-HUARD SAS - B.P. 49 - F - 44142 CHATEAUBRIANT CEDEX (FRANCE)

KUHN-GELDROP B.V. - P.O. Box 9 - 5660 AA GELDROP (THE NETHERLANDS)

KUHN NORTH AMERICA INC - P.O. Box 167 - Brodhead, WI 53520 (USA)

KUHN KRAUSE, INC. - PO. Box 2707 - Hutchinson, KS 67504 (USA)

KUHN DO BRASIL S/A PASSO FUNDO - RS - 99050-130 (BRASIL)

KUHN MONTANA SÃO JOSÉ DOS PINHAIS - PR - 83025-410 (BRASIL)



RAUCH Landmaschinenfabrik GmbH



Landstraße 14 · D-76547 Sinzheim



Victoria-Boulevard E200 · D-77836 Rheinmünster



info@rauch.de · www.rauch.de

Phone +49 (0) 7221/985-0

Fax +49 (0) 7221/985-200