

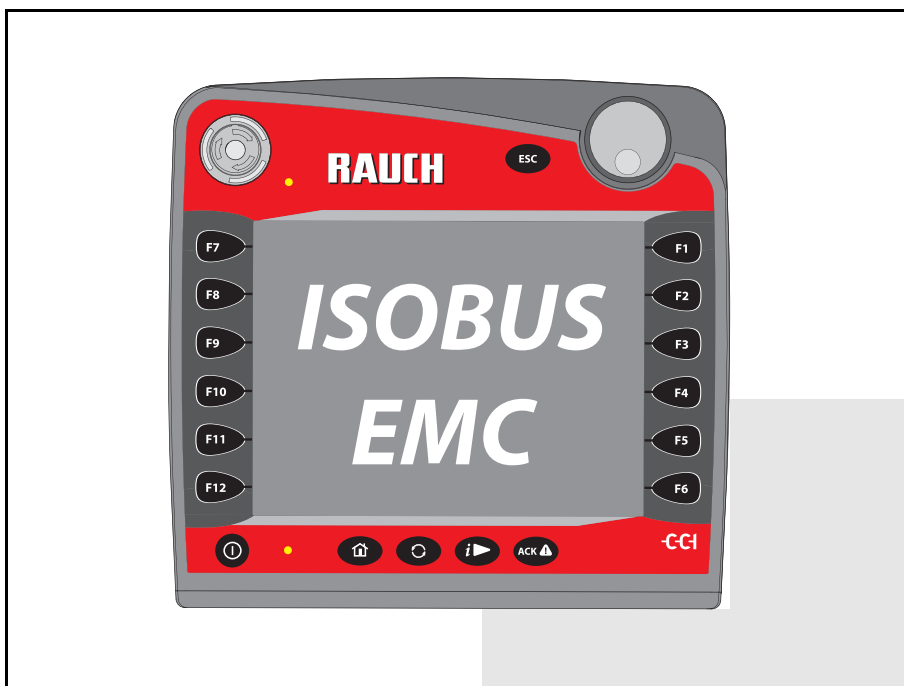

**RAUCH**

wir nehmen's genau

# INSTRUCTION MANUAL



**Please read carefully  
before using the ma-  
chine.**

Keep for future reference.

This instruction manual/assembly instruction is to be considered as part of the machine. Suppliers of new and second-hand machines are required to document in writing that the instruction manual/assembly instruction was delivered with the machine and handed over to the customer.

**AXIS-H ISOBUS**

Original instruction manual

5901205-e-en-1016

## Preface

Dear Customer

By purchasing the **control unit** AXIS-H ISOBUS for the mineral fertiliser spreader AXIS-H EMC, you have shown confidence in our product. Thank you very much! We want to justify this confidence. You have purchased a powerful and reliable **control unit**. If contrary to expectations any problems occur: our customer service is always there for you.



**Please read this operating manual as well as the operating manual of the machine carefully before commissioning and follow the advice given.**

This manual may also describe equipment that is not included in your **control unit**.

Please note that damage caused by incorrect operation or improper use may not be covered by warranty claims.

### NOTICE

#### **Note the serial number of the control unit and of the machine**

The control unit AXIS-H ISOBUS has been calibrated at the factory for the mineral fertiliser spreader with which it was supplied. It cannot be connected to another machine without requiring new calibration.

Please enter the serial number of the control unit and of the machine here. When connecting the control unit to the machine, these numbers must be checked.

---

Serial number of electronic control unit

Serial number AXIS-H EMC

Year of construction  
AXIS-H EMC

## Technical improvements

**We are continuously improving our products. Therefore, we reserve the right to make any improvements and changes to our machine that we consider necessary without notice. This constitutes no obligation to make such improvements or changes on machines that have already been sold.**

We will be pleased to answer any other questions that you might have.

Yours sincerely

RAUCH

Landmaschinenfabrik GmbH

## Preface

<b>1</b>	<b>User instructions</b>	<b>1</b>
1.1	About this operating manual	1
1.2	Information on the illustration.	1
1.2.1	Significance of warnings	1
1.2.2	Instructions and procedures.	3
1.2.3	Listings.	3
1.2.4	References.	3
1.2.5	Menu hierarchy, keys and navigation.	3
<b>2</b>	<b>Layout and function</b>	<b>5</b>
2.1	Overview of supported AXIS fertiliser spreaders.	5
2.2	Layout (CCI 100)	6
2.3	Control elements (CCI 100).	7
2.3.1	Overview	7
2.3.2	Touch screen	8
2.3.3	Function keys.	9
2.3.4	Scroll wheel	9
2.3.5	Stop switch.	10
2.4	Display.	11
2.4.1	Description of the working screen	11
2.4.2	Display fields	12
2.4.3	Display of the metering slide status	14
2.4.4	Display of sections.	15
2.5	Library of symbols used.	16
2.5.1	Navigation	16
2.5.2	Menus	17
2.5.3	Operating screen symbols	18
2.5.4	Other symbols	21
2.6	Structural menu overview	22
<b>3</b>	<b>Attachment and installation</b>	<b>23</b>
3.1	Requirements for the tractor	23
3.2	Connections, sockets.	23
3.2.1	Power supply	23
3.3	Connecting the machine control unit.	23
3.3.1	Standard schematic connection diagram.	24
3.3.2	Schematic connection diagram with torque sensor	25
3.4	Metering slide preparation.	26

<b>4</b>	<b>Operation AXIS-H ISOBUS</b>	<b>27</b>
4.1	Activating the machine control unit	27
4.2	Navigation within the menu	29
4.3	Main menu	30
4.4	Fertiliser settings	31
4.4.1	Application rate	33
4.4.2	Working width	35
4.4.3	Flow factor	35
4.4.4	Drop point	36
4.4.5	Calibration	37
4.4.6	Boundary spreading mode	40
4.4.7	Boundary quantity	40
4.4.8	Calculate OptiPoint	41
4.4.9	GPS-Control Info	43
4.4.10	Fertiliser charts	44
4.5	Machine settings	47
4.5.1	AUTO/MAN mode	50
4.5.2	+/- application rate	51
4.6	Fast emptying	52
4.7	System/Test	54
4.7.1	Total data counter	55
4.7.2	Test/diagnosis	56
4.7.3	Service	58
4.8	Information	59
4.9	Weighing trip counter	60
4.9.1	Trip counter	61
4.9.2	Rest (ka, ha, m)	62
4.9.3	Tare the scales (weighing spreader only)	63
4.10	Hopper cover	64
4.11	Special functions	66
4.11.1	Text input	66
4.11.2	Selection window	67
4.11.3	Using the joystick	68

---

<b>5</b>	<b>Spreading with the machine control unit AXIS-H ISOBUS</b>	<b>71</b>
5.1	Monitoring the remaining quantity during spreading (weighing spreaders only) . . .	71
5.2	Refilling (weighing spreader only) . . . . .	72
5.3	Working with sections . . . . .	73
5.3.1	Displaying the spreading type in the operating screen . . . . .	73
5.3.2	Spreading with reduced sections . . . . .	73
5.3.3	Spreading operation with one section and in the boundary spreading mode. .	76
5.4	Spreading with the AUTO km/h + AUTO kg operating mode . . . . .	77
5.5	Adaptive idle measurement . . . . .	78
5.5.1	Automatic idle measurement . . . . .	78
5.5.2	Manual idle measurement . . . . .	80
5.6	Spreading with AUTO km/h operating mode . . . . .	81
5.7	Spreading in the MAN km/h operating mode . . . . .	82
5.8	Spreading in the MAN scale operating mode . . . . .	83
5.9	GPS-Control . . . . .	85
<b>6</b>	<b>Alarm messages and possible causes</b>	<b>89</b>
6.1	Meaning of the alarm messages . . . . .	89
6.2	Fault/alarm . . . . .	92
6.2.1	Acknowledging an alarm message . . . . .	92
<b>7</b>	<b>Optional equipment</b>	<b>93</b>
	<b>Index</b>	<b>A</b>
	<b>Terms/conditions of warranty</b>	



# 1 User instructions

## 1.1 About this operating manual

This operating manual is an **Integral part** of the machine control unit.

The manual contains important instructions for **safe, proper** and **economic use** and **maintenance** of the machine control unit. Compliance with its stipulations helps to **Avoid risks**, reduce maintenance costs and downtime and to increase the machine's reliability and service life.

The operating manual is part of the machine. The complete documentation must be kept in an easily accessible location close to where the machine control unit is used (e.g. on the tractor).

The operating manual does not replace your **Own responsibility** as the operator and operating personnel of the machine control unit.

## 1.2 Information on the illustration

### 1.2.1 Significance of warnings

The warning instructions in this manual have been structured according to the degree of danger and the probability of their occurrence.

Danger signs and symbols inform the user about other construction-related and unavoidable residual risks that may be encountered when operating the machine. The warning notes used are structured as follows:

<b>Signal word</b>	
Symbol	Explanation
<b>Example</b>	
<b>▲ DANGER</b>	
	<p><b>Risk to life if warning is not observed</b></p> <p>Description of the danger and possible consequences.</p> <p>Ignoring these warnings will result in very serious or even fatal injury.</p> <p>► Measures to prevent the danger.</p>

### Warning severity level

The degree of danger is indicated by the signal word. The levels are classified as follows:

#### **▲ DANGER**



##### **Type and source of danger**

This warning warns of a danger posing an immediate threat to the health and life of persons.

Ignoring these warnings will result in very serious or even fatal injury.

- ▶ Always observe the measures described to prevent this danger.

---

#### **▲ WARNING**



##### **Type and source of danger**

This warning warns of a possible dangerous situation for the health of persons.

Ignoring these warnings will result in very serious injury.

- ▶ Always observe the measures described to prevent this danger.

---

#### **▲ CAUTION**



##### **Type and source of danger**

This warning warns of a potentially dangerous situation for personal health or of material and environmental damage.

Ignoring this warning can result in injuries and damage to the product or the general area.

- ▶ Always observe the measures described to prevent this danger.

---

#### **NOTICE**

General information containing application tips and particularly useful information, but which constitutes neither warnings nor hazards.

---



## 1.2.2 Instructions and procedures

Steps that the operator must carry out are shown as a numbered list.

1. Instruction for action step 1
2. Instruction for action step 2

Instructions involving only one step are not numbered. The same applies for action steps that do not have a specific sequence.

A bullet is placed in front of these instructions:

- Handling instruction

## 1.2.3 Listings

Listings without a specific sequence are shown with bullet points (level 1) and dashes (level 2):

- Property A
  - Point A
  - Point B
- Property B

## 1.2.4 References

References to other text passages in the document are indicated with section number, headline text and page number:

- **Example:** See also chapter [3: Safety, page 5](#).

References to other documents are indicated as note or instruction without exact chapter or page number:

- **Example:** Please also observe the instructions contained in the manual for the universal drive shaft.

## 1.2.5 Menu hierarchy, keys and navigation

**Menus** are the entries listed in the **Main menu** window.

In the menus, **submenus and/or menu items** are listed in which settings can be implemented (selection lists, text or number entries, starting a function).

The various menus and buttons of the machine control unit are illustrated in **bold** letters:

The hierarchy and the path to the requested menu item are marked with an > (arrow) between menu, menu item/s:

- **System / test > Test/diagnosis > Voltage** means that you can access the **Voltage** menu item via the **System / test** menu and the **Test/diagnosis** menu item.
  - The arrow > corresponds to the operation of the **scroll wheel** and/or the button at the screen (touch screen).



## 2 Layout and function

### NOTICE

Due to the great variety of different ISOBUS-compatible terminals, the present chapter is restricted to the layout and the functions of the **CCI 100** ISOBUS terminal as example.

- Please observe the instructions in the respective operating manual of your ISOBUS terminal.

### 2.1 Overview of supported AXIS fertiliser spreaders

Fertiliser spreader type	AXIS-H 30.1 EMC 30.2 EMC	AXIS-H 30.1 EMC + W 30.2 EMC + W	AXIS-H 50.1 EMC + W 50.2 EMC + W	AXIS-H 50.1 EMC + W-2
Spreading operations depending on the forward speed	•	•	•	•
Weigh cells		•	•	•
Electrical drop point setting	•	•	•	•
RPM control	•	•	•	•
EMC mass flow control	•	•	•	•

2.2 Layout (CCI 100)

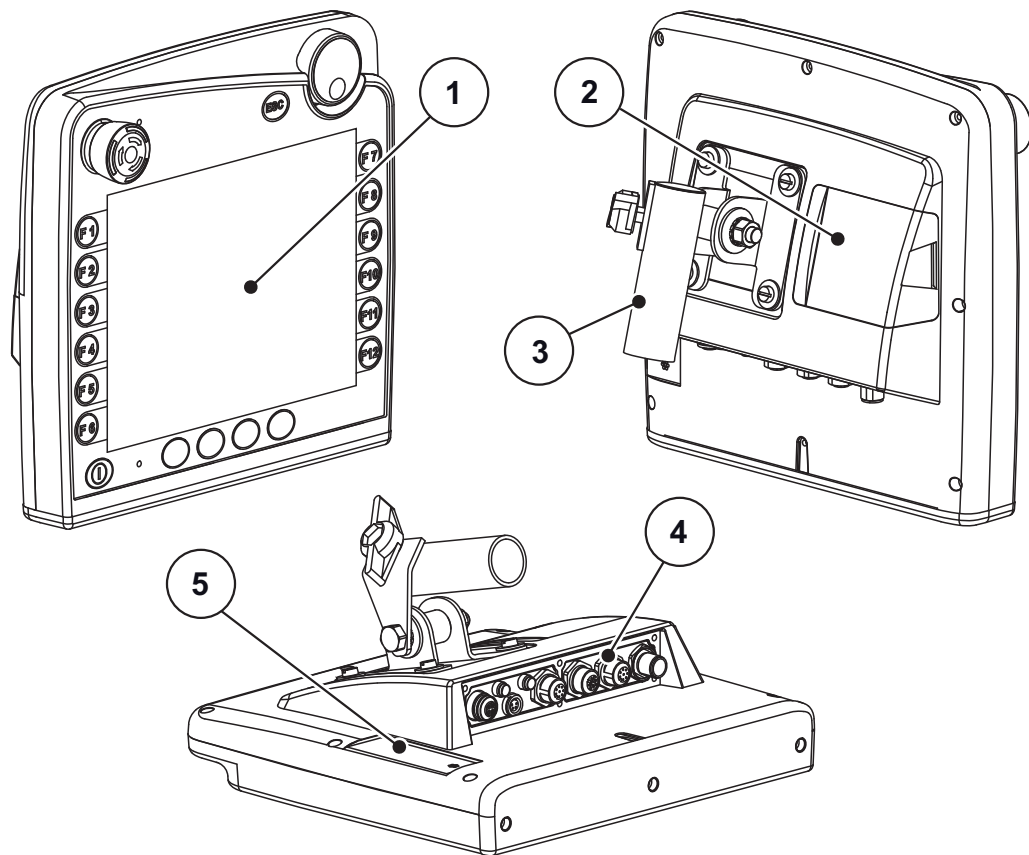

Figure 2.1: Terminal CCI 100 overview

No.	Designation	Function
1	Operating panel	Including foil buttons, display, scroll wheel and stop switch.
2	USB port with cover	Protects the USB port from dirt. For data exchange, task controller and terminal updates.
3	Mounting bracket	For mounting the terminal within the tractor cabin.
4	Terminal strip	Terminal strip for the cables of the ISOBUS system.
5	Softkey switch	Enables switching the functions from the left to the right side of the screen.

## 2.3 Control elements (CCI 100)

### 2.3.1 Overview

The CCI 100 machine control unit is operated with the following control elements:

- **18 foil buttons** (6 firmly defined, 12 freely assignable foil buttons).
- Scroll wheel
- Stop switch
- Softkey switch

#### NOTICE

For further information on operating the CCI 100 terminal and its control elements, refer to the enclosed operating manual. The operating manual is an integral part of the terminal unit.

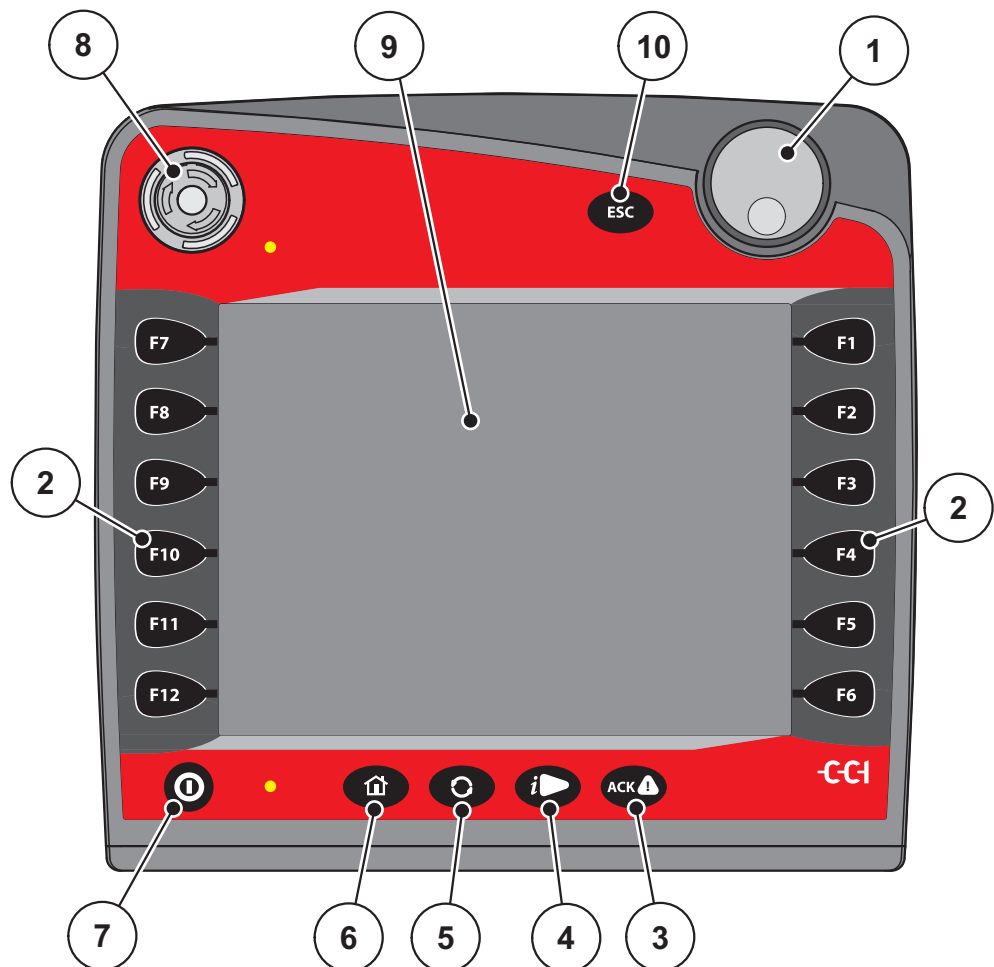

**Figure 2.2:** Operating panel on the front side of the unit

No.	Designation	Function
1	Scroll wheel	Navigation through the menus and input fields and to acknowledge entries.
2	Function keys F1 - F12	12 keys with variable functionalities, depending on the menu screen. <a href="#">Page 9</a>
3	<b>ACK</b> key	Acknowledgement of error messages.
4	<b>Information</b> key	Freely assignable key. Refer to the CCI 100 terminal operating manual.
5	<b>Double arrow</b> key	Navigation between the system screens of the terminal.
6	<b>Main menu</b> key	Changing to the main menu of the terminal (refer to the manufacturer operating manual).
7	ON/OFF	Switching the terminal on/off.
8	Stop switch	The stop switch puts the connected devices into a safe state. Not all ISOBUS terminals support the stop switch. <a href="#">Page 10</a>
9	Touch screen	<ul style="list-style-type: none"> <li>● Direct activation of the button</li> <li>● Input of values</li> </ul>
10	<b>ESC</b> key	Cancelling inputs.

### 2.3.2 Touch screen

The CCI 100 terminal is equipped with a touch screen. The buttons on the screen (OK, symbols in the working screen, etc.) can be pressed and menu entries can be opened directly.

**NOTICE**

Please observe the operating manual of the CCI 100 terminal. The operating manual is an integral part of the terminal/machine.

---

### 2.3.3 Function keys

Depending on the type of terminal, it can be equipped with **2x5** (minimum requirement) or **2x6** function keys. On the left and right-hand side, next to the screen of the CCI 100 ISOBUS terminal, two groups of 6 function keys each are allocated in a vertical position.

The assignment of the function keys depends on the displayed menu screens. Functions are generally executed by pressing the function key next to the icon or by pressing the button on the touch screen.

Function keys without icon do not have **any** functionality in the respective menu screens.

### 2.3.4 Scroll wheel

The scroll wheel is used for fast navigation in the menus as well as for entering or changing data in input fields.

- Turning the scroll wheel enables navigation between the selectable fields.
- Pressing the scroll wheel to confirm the selection.



**Figure 2.3:** Scroll wheel at the CCI 100

### 2.3.5 Stop switch

By pressing the stop switch, all connected devices are set to a safe state.

- The stop switch pops out again if it is turned in the direction of the arrow.
  - ▷ The stop switch is then unlocked.



**Figure 2.4:** Stop switch at the CCI 100

#### Case 1 - Spreading operation

Pressing the stop switch during spreading operation:

- closes the metering slide
- stops the drop point actuator
- stops the spreading disc drive

#### Case 2 - No spreading operation (example: calibration/fast emptying)

If no spreading operation is active, all functions are stopped and the metering slides remain open.

### ⚠ CAUTION



#### Risk of injury due to components operated by an external force

The stop switch does **NOT** interfere in tractor functions. Components may move despite the activation of the stop switch and cause personal injury.

- ▶ Deactivate the hydraulic system of the tractor.
- ▶ Ensure that nobody is present in the hazard zone.

A warning message is displayed as soon as the stop switch is actuated.

1. Rectify the cause of the fault.
2. Unlock the stop switch
  - ▷ Another alarm message warning against potential unexpected movements is displayed.
3. Press the **ACK** foil key





## 2.4 Display

The display shows the current status information as well as the selection and input options for the machine control unit.

The most important information on the operation of the mineral fertiliser spreader is displayed on the **working screen**.

### 2.4.1 Description of the working screen

#### NOTICE

The exact representation of the working screen depends on the actual settings selected.

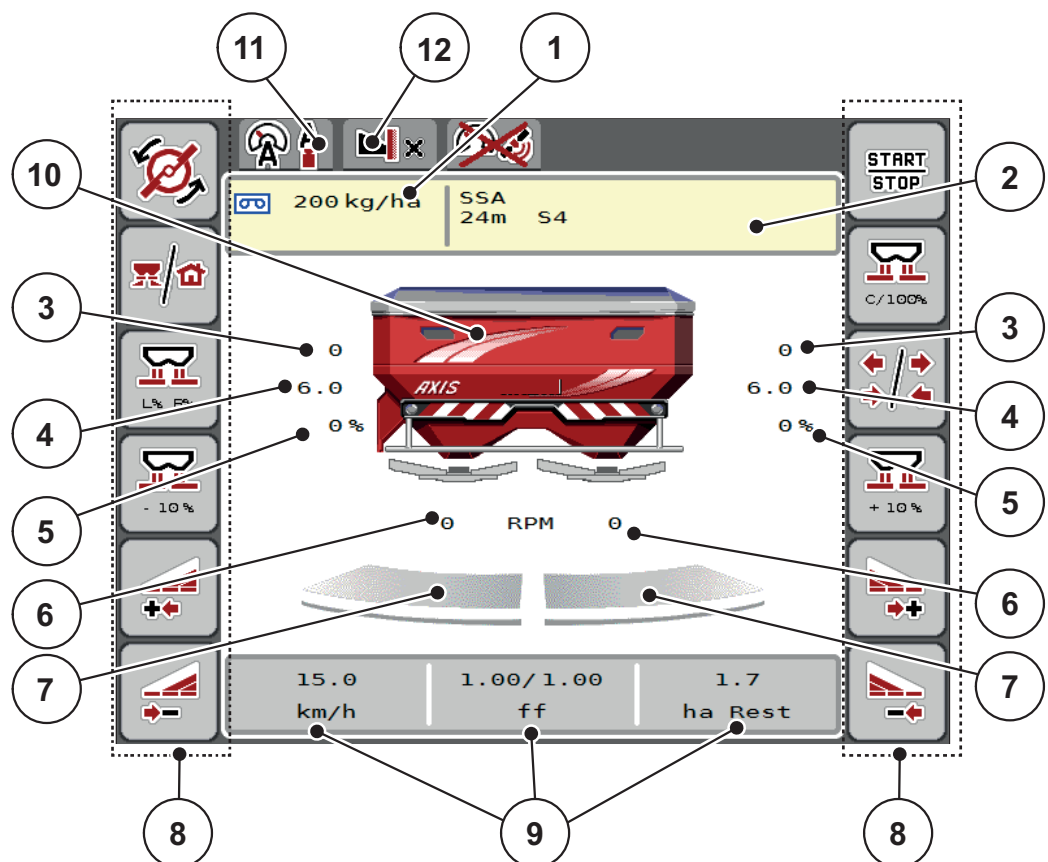

**Figure 2.5:** Machine control unit display

- [1] Current application rate from the fertiliser settings or the task controller
- [2] Fertiliser information display (fertiliser name, working width and spreading disc type)
- [3] Metering slide position, right/left
- [4] Drop point position, right/left
- [5] Quantity change, right/left
- [6] Spreading disc speed, right/left
- [7] Metering slide opening status, right/left
- [8] Function keys
- [9] Freely definable display fields
- [10] Mineral fertiliser spreader display
- [11] Selected operating mode
- [12] Display of full border/limited border spreading mode

### 2.4.2 Display fields

The three display fields in the operating screen ([Figure 2.5](#), Position [9]) can be individually adjusted and optionally assigned with the following values:

- Forward speed
- Flow factor (FF)
- ha trip
- kg trip
- m trip
- kg left
- m left
- ha left
- Idling (time until the next idle measurement)
- Differential pressure (pressure at the hydraulic engine of the spreading disc drive)

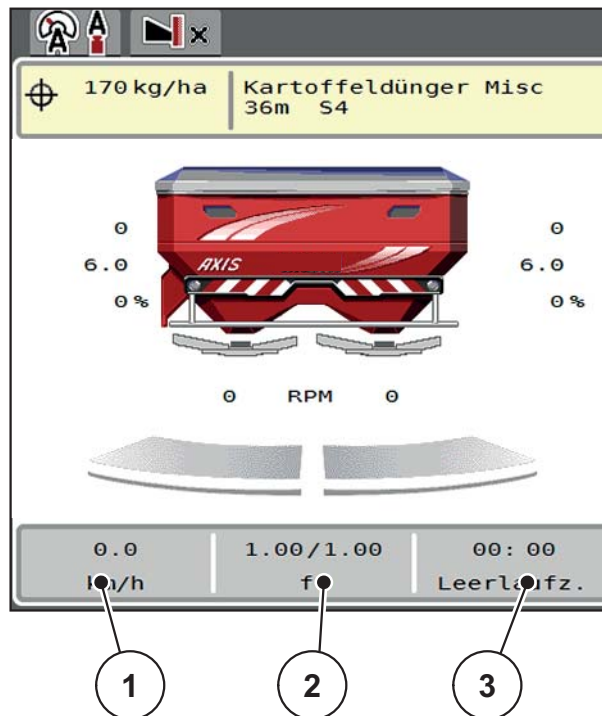

**Figure 2.6:**

- [1] Display field 1
- [2] Display field 2
- [3] Display field 3

**Select display**

1. Press the required **display field** on the touch screen.

Alternative: Select the **display field** with the scroll wheel and press the scroll wheel.

▷ The possible displays are listed in the display.

2. Highlight the new value which is to be assigned to the display field.

3. Press the **OK button or the scroll wheel**.

▷ The **operating screen** is displayed. The respective **display field** displays the new value.

2.4.3 Display of the metering slide status

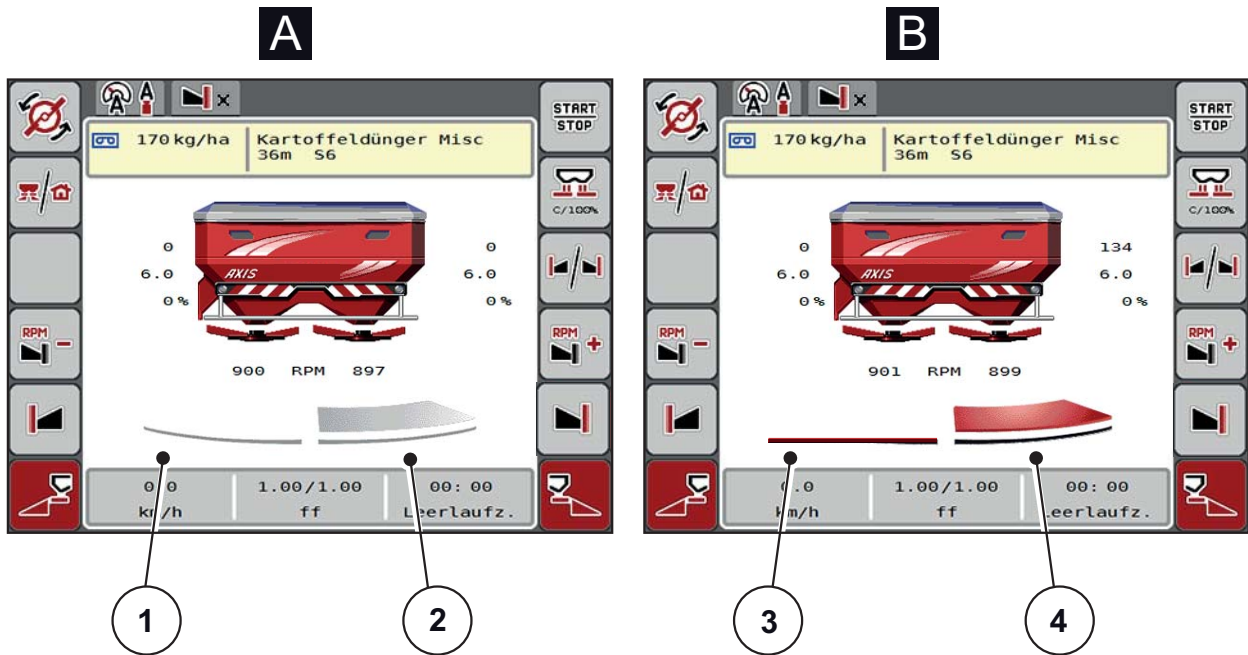

Figure 2.7: Display of the metering slide status

[A] Spreading operation inactive (STOP)

[1] Section deactivated

[2] Section activated

[B] Machine in spreading mode (START)

[3] Section deactivated

[4] Section activated

### 2.4.4 Display of sections

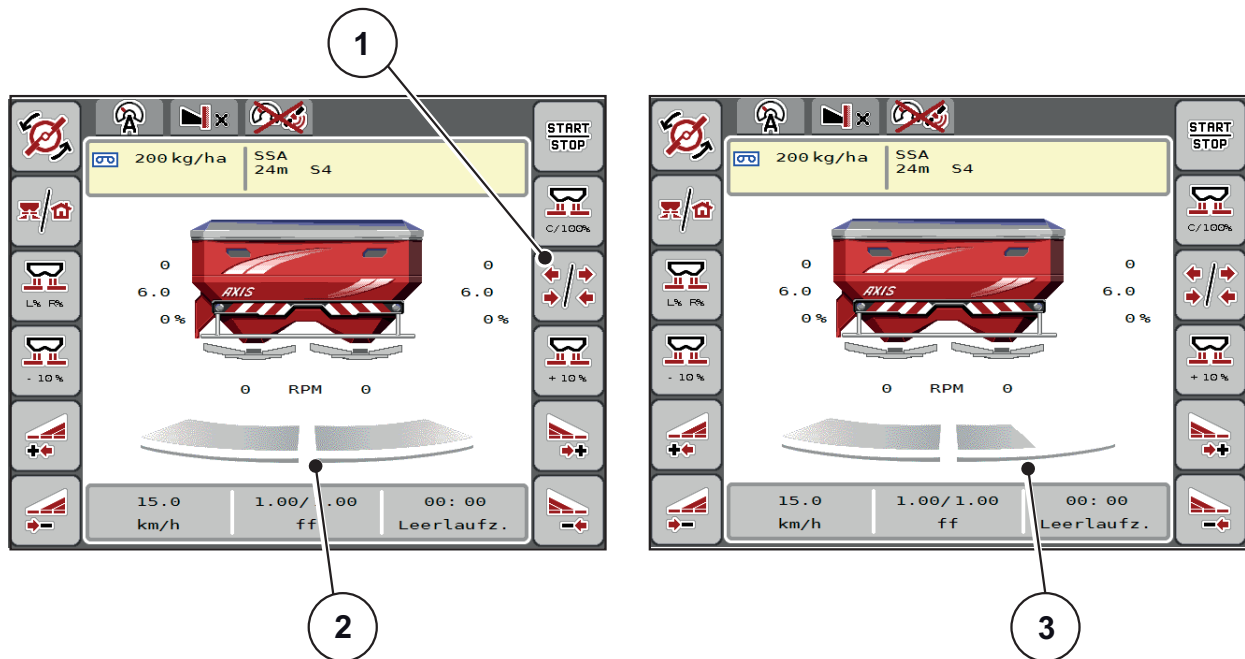

**Figure 2.8:** Display of the section status







- [1] Sections/boundary spreading Approach drop point key
- [2] Activated sections with 4 possible spreading width steps
- [3] The right section is reduced by 2 section steps

Further display and setting options are explained in chapter [5.3: Working with sections, page 73](#).









### 2.5 Library of symbols used

The screen of the AXIS ISOBUS control unit displays symbols for menus and functions.













#### 2.5.1 Navigation

Symbol	Meaning
	To the left; previous page
	To the right; next page
	Back to the previous menu
	Back to main menu
	Changing between operating screen and menu window
	Acknowledgement of error messages.
	Cancellation, closing the dialogue window



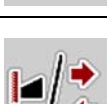









## 2.5.2 Menus







Symbol	Meaning
	Changing directly to the main menu from a menu window
	Changing between operating screen and menu window
	Hopper cover
	Fertiliser settings
	Machine settings
	Fast emptying
	System/test
	Information
	Weighing trip counter

2.5.3 Operating screen symbols











Symbol	Meaning
	Start the application rate regulation
	The spreading operation has started; stop the application rate regulation
	Start spreading discs
	Rotate the spreading discs; stop the spreading discs
	Reset the quantity adjustment to the pre-set application rate.
	Changing between operating screen and menu window
	Change between boundary spreading and sections on the left, right or both spreading sides.
	Sections on the left side, boundary spreading on the right spreading side.
	Sections on the right side, boundary spreading on the left spreading side.
	Boundary spreading on the left, right or both spreading sides.
	Selection of the surplus/shortage quantity on the left, right or both spreading sides (%)
	Quantity adjustment + (plus)



Symbol	Meaning
	Quantity adjustment - (minus)
	Quantity adjustment, left + (plus)
	Quantity adjustment, left - (minus)
	Quantity adjustment, right + (plus)
	Quantity adjustment, right - (minus)
	Manual quantity adjustment + (plus)
	Manual quantity adjustment - (minus)
	Increasing the spreading disc speed (plus)
	Reducing the spreading disc speed (minus)
	Left spreading side inactive
	Left spreading side active
	Right spreading side inactive
	Right spreading side active

Symbol	Meaning
	Reduce section, right (minus)
	Increase right section (plus)
	Activate right boundary spreading function
	Right boundary spreading function active
	Activate left boundary spreading function
	Left boundary spreading function active

2.5.4 Other symbols

Symbol	Meaning
	Start idle measurement, in the main menu
	Limited border spreading, environment-oriented, in the operating screen
	Full border spreading, yield-oriented, in the operating screen
	Limited border spreading, environment-oriented, in the main menu
	Full border spreading, yield-oriented, in the main menu
	Operating mode AUTO km/h + AUTO kg
	Operating mode AUTO km/h
	Operating mode MAN km/h
	Operating mode MAN scale
	Loss of GPS signal

2.6 Structural menu overview

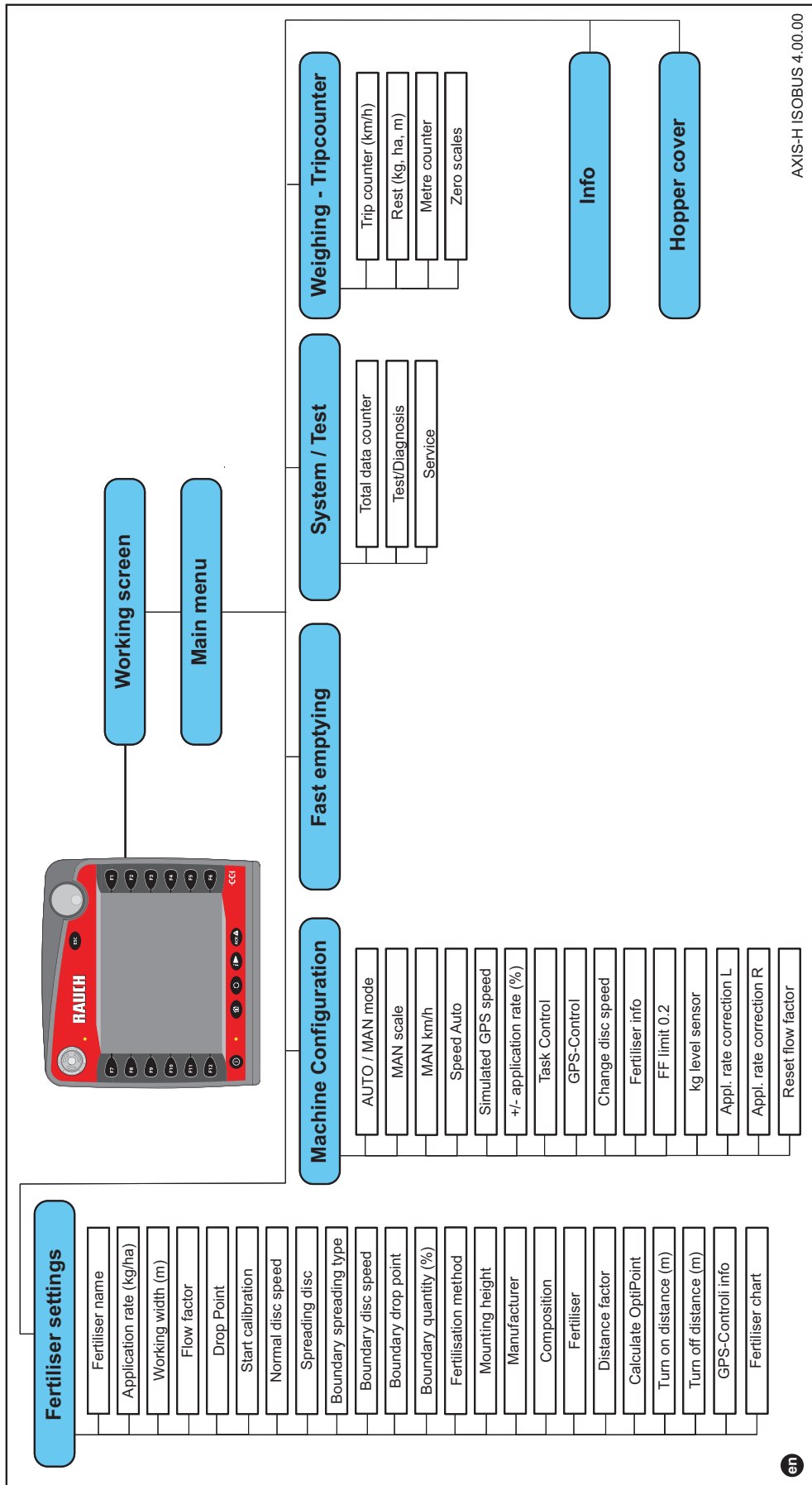

## 3 Attachment and installation

### 3.1 Requirements for the tractor

Before installing the machine control unit, ensure that your tractor meets the following requirements:

- A minimum voltage of **11 V** must **always** be guaranteed, even if multiple loads are connected simultaneously (e.g. air conditioning system, lights),
- Oil supply: **max. 210 bar**, single or double-acting valve (depending on equipment),
- Hydraulic capacity AXIS H 30 EMC: **45 l/min**, constant current or load sensing system,
- Hydraulic capacity AXIS H 50 EMC: **65 l/min**, constant current or load sensing system,
- Free return **min. internal diameter of 18 mm**,
- 9-pin socket (ISO 11783) located at the rear of the tractor, for connecting the machine control unit to ISOBUS,
- 9-pin terminal plug (ISO 11783) for connecting an ISOBUS terminal to the ISOBUS.

#### NOTICE

If the tractor is not equipped with a 9-pin socket at the rear, a tractor assembly set including a 9-pin socket for the tractor (ISO 11783) and a forward speed sensor may be purchased additionally as special equipment.

### 3.2 Connections, sockets

#### 3.2.1 Power supply

The power supply of the machine control unit is implemented via the 9-pin socket at the rear of the tractor.

### 3.3 Connecting the machine control unit

Depending on the equipment, there are different methods for connecting the machine control unit to the mineral fertiliser spreader. Further information can be obtained from the operating manual of your machine control unit.

3.3.1 Standard schematic connection diagram

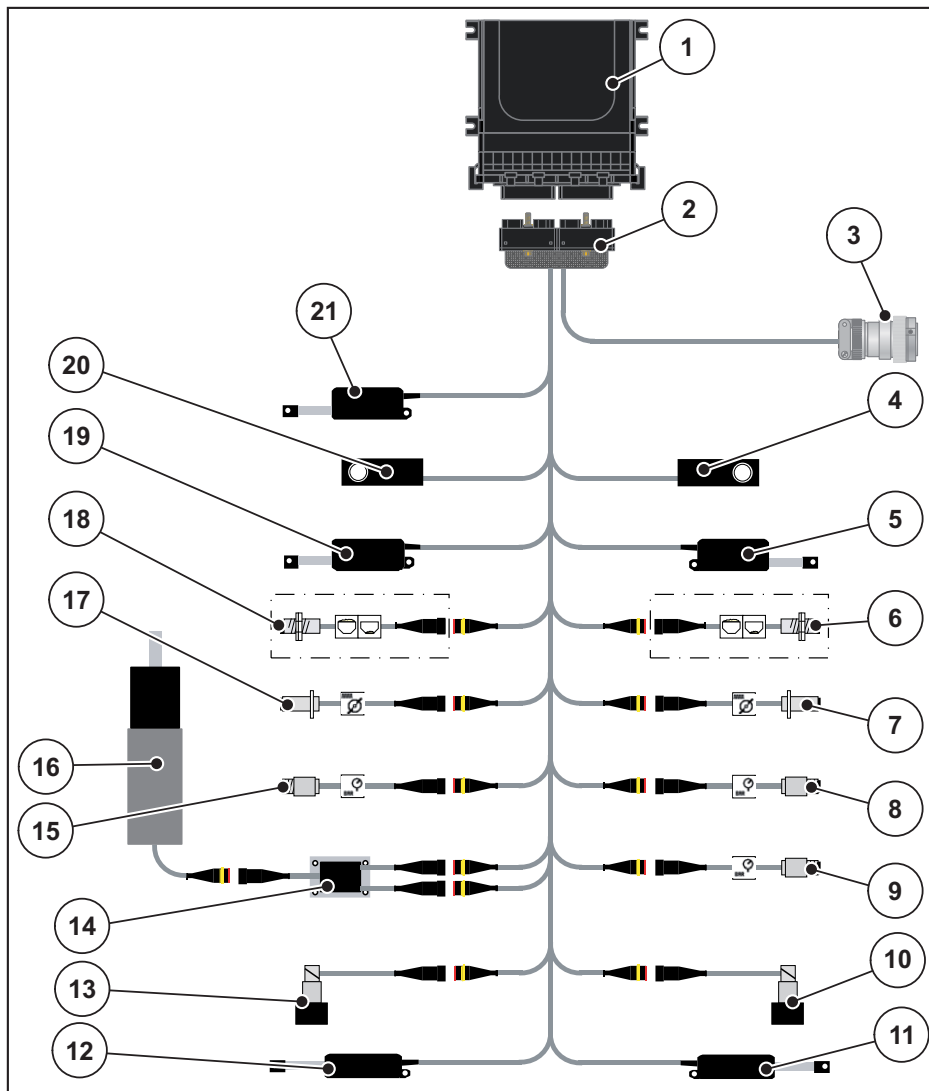

Figure 3.1: Standard schematic connection diagram

- [1] Machine control unit
- [2] Machine plug
- [3] ISOBUS connector plug
- [4] Weigh cell, right
- [5] Metering slide actuator, right
- [6] Level sensor, right
- [7] Spreading disc speed sensor, right
- [8] Pressure sensor, right
- [9] Pressure sensor, return flow
- [10] Proportional valve, right
- [11] Drop point actuator, right
- [12] Drop point actuator, left
- [13] Proportional valve, left
- [14] Agitator over-voltage protection
- [15] Pressure sensor, left
- [16] Electric agitator motor
- [17] Spreading disc speed sensor, left
- [18] Level sensor, left
- [19] Metering slide actuator, left
- [20] Weigh cell, left
- [21] Hopper cover actuator

3.3.2 Schematic connection diagram with torque sensor

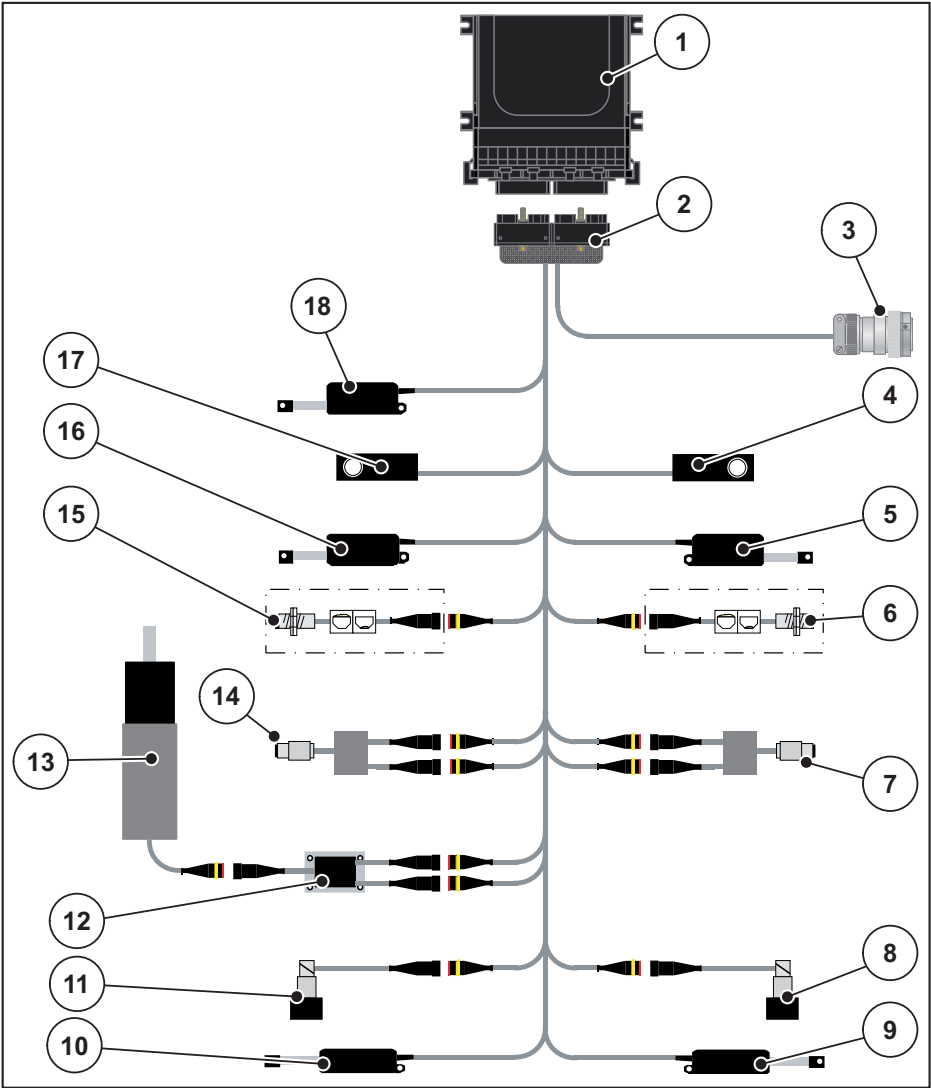

Figure 3.2: Schematic connection diagram with torque sensor

- [1] Machine control unit
- [2] Machine plug
- [3] ISOBUS connector plug
- [4] Weigh cell, right
- [5] Metering slide actuator, right
- [6] Level sensor, right
- [7] Torque/RPM sensor, right
- [8] Proportional valve, right
- [9] Drop point actuator, right
- [10] Drop point actuator, left
- [11] Proportional valve, left
- [12] Agitator over-voltage protection
- [13] Electric agitator motor
- [14] Torque/RPM sensor, left
- [15] Level sensor, left
- [16] Metering slide actuator, left
- [17] Weigh cell, left
- [18] Hopper cover actuator

### 3 Attachment and installation

---

#### 3.4 Metering slide preparation

The AXIS-H EMC mineral fertiliser spreaders are equipped with an electronic slide actuator for the application rate adjustment.

***NOTICE***

Observe the operating manual of your mineral fertiliser spreader.

---



## 4 Operation AXIS-H ISOBUS

### ⚠ CAUTION



#### Risk of injury due to ejected fertiliser

In the event of a fault, the metering slide may open unexpectedly when driving to the spreading location. There is a risk of slipping and personal injury due to discharged fertiliser.

- ▶ **Before driving to the spreading location**, the electronic machine control unit AXIS-H ISOBUS is to be switched off at all times.

### 4.1 Activating the machine control unit

#### Requirements:

- The machine control unit is properly connected to the mineral fertiliser spreader and the tractor (an example is provided in chapter [3.3: Connecting the machine control unit, page 23](#)).
- A minimum voltage of **11V** is guaranteed.

### NOTICE

The operating manual describes the functions of the machine control unit **as of software version 4.00.00**.

Activation:



Figure 4.1: Start AXIS-H ISOBUS

[1] ON/OFF switch

1. Actuate the **ON/OFF switch** [1].
  - ▷ After a few seconds, the **start-up screen** of the machine control unit is displayed.
  - ▷ Subsequently, the machine control unit displays the **activation menu** for a few seconds.



2. Press the **Enter** key [1].
  - ▷ **Subsequently, the operating screen appears.**

## 4.2 Navigation within the menu

### NOTICE

Important notes regarding the display and the navigation between menus are provided in chapter [1.2.5: Menu hierarchy, keys and navigation, page 3](#).

Below, accessing menus and menu entries **by touching the touch screen or pressing the function keys** is described. Menus can also be accessed by means of the scroll wheel (turning/pressing).

- Observe the operating manual of the terminal used.

### Accessing the main menu



- Press the **Operating screen/main menu** function key. See [2.5.2: Menus, page 17](#).
  - ▷ The main menu appears on the display.

### Accessing a sub-menu with the scroll wheel:

1. Move the scroll wheel.
  - ▷ A selection bar moves up and down.
2. Highlight the desired sub-menu with the bar on the display.
3. Access the selected sub-menu by pressing the scroll wheel.

### Accessing the sub-menu via the touch screen:

1. Press the button of the desired sub-menu.

Windows appear which prompt various actions.

- Text input
- Value input
- Settings made via further sub-menus

### NOTICE

Not all parameters are displayed simultaneously in one menu window. The **Arrow keys (left/right)** enable changing over to the next or previous windows.

### Exiting the menu



- Confirm settings by pressing the **Return** key.
  - ▷ You will return to the **Previous menu**.
- Press the **Operating screen/main menu** key.
  - ▷ The **Operating screen** is displayed.
- **Press the ESC** key.
  - ▷ The previous settings are maintained.
  - ▷ You will return to the **Previous menu**.

4.3 Main menu

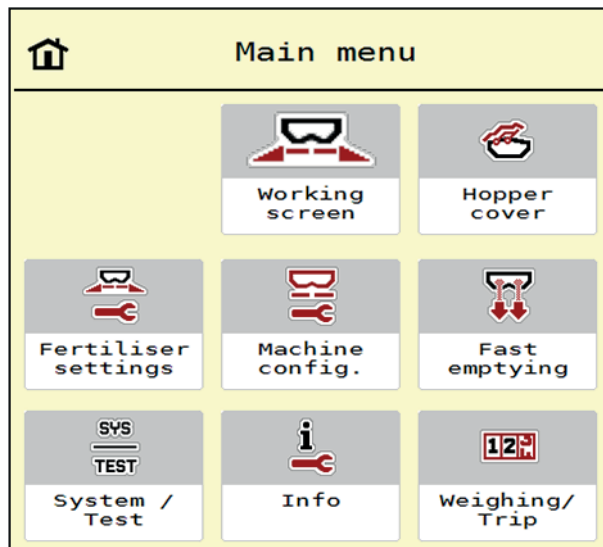

Figure 4.2: Main menu with sub-menus

Sub-menu	Meaning	Description
Hopper cover	Opening/closing the hopper cover	<a href="#">Page 64</a>
Fertiliser settings	Fertiliser and spreading operation settings	<a href="#">Page 31</a>
Machine settings	Tractor and mineral fertiliser spreader settings	<a href="#">Page 47</a>
Fast emptying	Direct access to the menu for a fast emptying of the fertiliser spreader	<a href="#">Page 52</a>
System / test	Settings and diagnosis of the machine control unit.	<a href="#">Page 54</a>
Information	Machine configuration display	<a href="#">Page 59</a>
Weighing trip counter	Values of the implemented spreading work and functions for weighing operation.	<a href="#">Page 60</a>



In addition to the sub-menus, in the **Main menu** the **Idle measurement** and **Boundary spreading type** function keys can be selected.

- Idle measurement: This function key enables a manual start of the idle measurement. See [5.5.2: Manual idle measurement, page 80](#)
- Boundary spreading type: You can choose between boundary spreading for the environment or boundary yield spreading.

### 4.4 Fertiliser settings



In this menu, the fertiliser and spreading operation settings are implemented.

- Open the **Main menu > Fertiliser settings** menu.

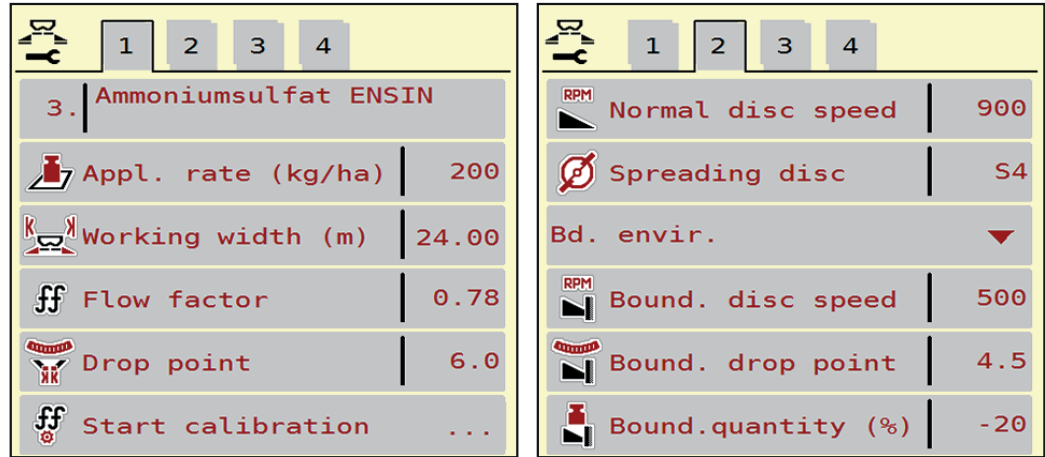

Figure 4.3: Fertiliser settings menu, tab 1 and 2

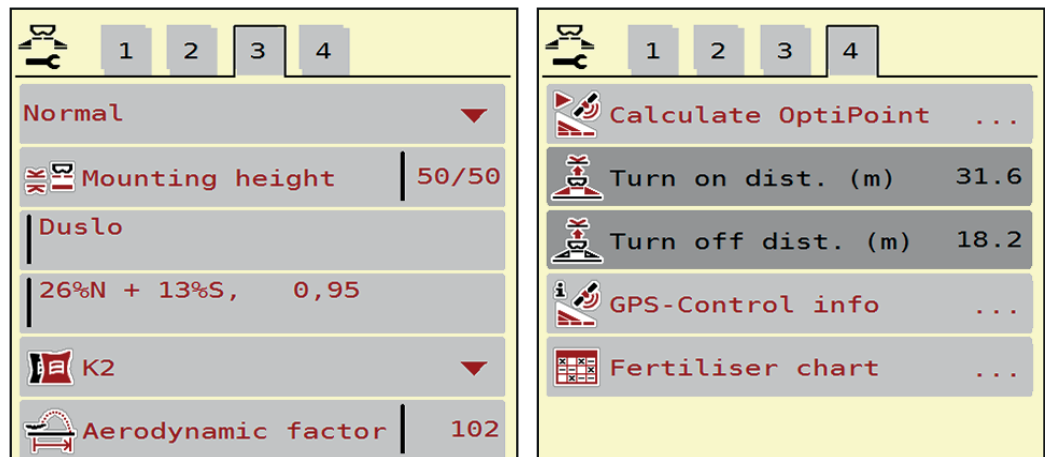

Figure 4.4: Fertiliser settings menu, tab 3 and 4

**NOTICE**

Not all parameters are displayed simultaneously on screen. The **Arrow keys (left/right)** enable a change over to the adjacent menu window (tab).

Sub-menu	Meaning/possible values	Description
Fertiliser name	Fertiliser selected from the fertiliser chart.	<a href="#">Page 44</a>
Appl. rate (kg/ha)	Input of target value for the application rate in kg/ha.	<a href="#">Page 33</a>
Working width (m)	Determination of the working width to be spread.	<a href="#">Page 35</a>
Flow factor	Input of the flow factor of the fertiliser used.	<a href="#">Page 36</a>
Drop point	Input of the drop point.	Please observe the machine's operating manual. <a href="#">Page 36</a>
Start the calibration	Open the sub-menu for executing the calibration.	<a href="#">Page 37</a>
Normal disc speed	Input of the desired spreading disc speed.	To be entered in a separate input window.
Spreading disc	Setting of the spreading disc type mounted at the mineral fertiliser spreader. (influences the EMC mass flow control)	Selection list: <ul style="list-style-type: none"> <li>● S1</li> <li>● S4</li> <li>● S6</li> <li>● S8</li> <li>● S10</li> <li>● S12</li> </ul>
Boundary spreading type	Selection of the desired fertilisation method, sorted by limited border spreading (environment) and full border spreading (yield).	<a href="#">Page 40</a>
Boundary disc speed	Pre-setting the RPM in the boundary spreading mode.	To be entered in a separate input window.
Boundary spreading drop point	Pre-setting the drop point in the boundary spreading mode.	To be entered in a separate input window.
Boundary quantity	Pre-setting the quantity reduction in the boundary spreading mode.	To be entered in a separate input window.

Sub-menu	Meaning/possible values	Description
Normal/late	Selection of the desired fertilisation method, sorted by normal and late fertilising.	
Mounting height	Indicated in cm front/cm rear Selection list: <ul style="list-style-type: none"> <li>● 0/6</li> <li>● 40/40</li> <li>● 50/50</li> <li>● 60/60</li> <li>● 70/70</li> <li>● 70/76</li> </ul>	
Manufacturer	Entry of the fertiliser manufacturer.	
Composition	Percentage content of chemical composition.	
Distance factor	Input of the distance factor via the fertiliser chart. Required for OptiPoint calculation	
Calculate OptiPoint	Input of the GPS-Control parameters	<a href="#">Page 41</a>
Turn on distance (m)	Input of switch-on distance.	
Turn off distance (m)	Input of switch-off distance.	
GPS-Control information	Display of information of the GPS-Control parameters.	<a href="#">Page 43</a>
Fertiliser chart	Management of fertiliser charts.	<a href="#">Page 44</a>

#### 4.4.1 Application rate



In this menu, you can enter the desired target value for the application rate.

##### Entering the application rate:

1. Open the **Fertiliser settings > Application rate (kg/ha)** menu.
  - ▷ The **currently applied** application rate is displayed.
2. Enter the new value in the input field.
3. Press **OK**.
  - ▷ **The new value is saved in the machine control unit.**

You can also enter or adjust the application rate directly via the operating screen.

1. Press the application rate [1] button on the touch screen.
  - ▷ The number input window is displayed.

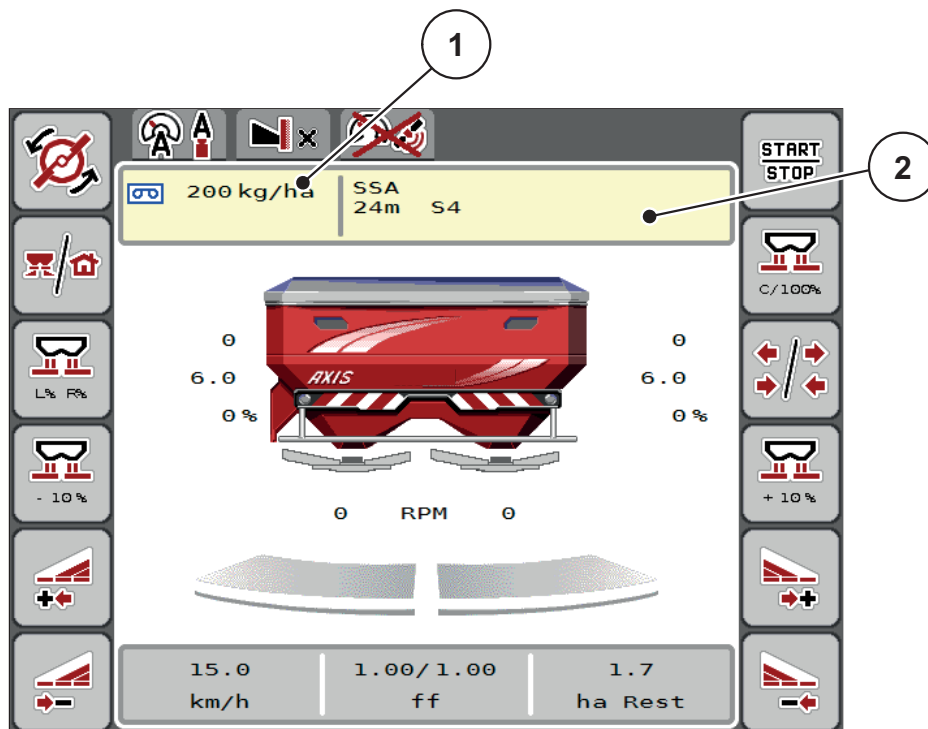

**Figure 4.5:** Entering the application rate on the touch screen

- [1] Application rate button
- [2] Fertiliser chart button

2. Enter the new value in the input field.
3. Press **OK**.
  - ▷ **The new value is saved in the machine control unit.**



#### 4.4.2 Working width



In this menu, you can set the working width (in metres).

1. Open the **Fertiliser settings > Working width (m)** menu.
  - ▷ The **currently applied** working width is displayed.
2. Enter the new value in the input field.
3. Press **OK**.
  - ▷ **The new value is saved in the machine control unit.**

#### 4.4.3 Flow factor



The flow factor lies within the range of **0.4** to **1.9**. The following applies under the same basic conditions (km/h/, working width, kg/ha):

- If the flow factor is **raised**, the dosing quantity is **reduced**.
- If the flow factor is **reduced**, the dosing quantity is **raised**.

An error message is displayed if the flow factor is outside the preset range. Refer to [6: Alarm messages and possible causes, page 89](#). If you spread organic fertiliser or rice, you need to reduce the minimum factor to 0.2. Otherwise the error message will be displayed constantly.

- Activate the > FF limit 0.2 in the machine settings.
  - Refer to [4.5: Machine settings, page 47](#).

If you have obtained the flow factor from earlier calibrations or from the fertiliser chart, insert it **manually** into this selection window.

#### NOTICE

In the **Calibration start** menu, the flow factor can be determined and entered by means of the machine control unit. Refer to chapter [4.4.5: Calibration, page 37](#)

With the AXIS-H EMC mineral fertiliser spreader, the flow factor is calculated via the EMC mass flow control. However, the data may also be entered manually.

#### NOTICE

The flow factor calculation depends on the operating mode used. For further information on the flow factor, please refer to chapter [4.5.1: AUTO/MAN mode, page 50](#).

#### Entering the flow factor:

1. Open the **Fertiliser settings > Flow factor** menu.
  - ▷ The **currently set** flow factor is displayed.
2. Enter the value obtained from the fertiliser chart into the input field.

### NOTICE

If the fertiliser is not listed in the fertiliser chart, a flow factor of **1.00** is to be entered.

In the **AUTO km/h operating mode**, we highly recommend implementing a **calibration** in order to be able to accurately determine the flow factor for this fertiliser.

---

3. Press **OK**.

▷ **The new value is saved in the machine control unit.**

### NOTICE

For the AXIS-H EMC mineral fertiliser spreader (**AUTO km/h + AUTO kg** operating mode), we recommend having the flow factor displayed in the operating screen. By doing so, you can observe the flow factor control during spreading. See [2.4.2: Display fields, page 12](#)

---

#### 4.4.4 Drop point



With the AXIS-H EMC mineral fertiliser spreader, the drop point is set via the electrical drop point adjustment exclusively.

1. Open the **Fertiliser settings > Drop point** menu.

2. Determine the position for the drop point using the fertiliser chart.

3. Enter the determined value in the input field.

4. Press **OK**.

▷ **The Fertiliser settings window with the new drop point is displayed.**

If the drop point is blocked, alarm 17 appears; see chapter [6: Alarm messages and possible causes, page 89](#).

### ▲ CAUTION



#### Risk of injury due to automatic drop point adjustment

Upon actuation of the **Start/Stop** function key, the drop point is automatically moved to the pre-set value by means of electrical actuating cylinders. This may cause injury.

- ▶ Before actuating the **Start/Stop** key, ensure that nobody is present in the danger zone of the machine.
  - ▶ Acknowledge the “Move to drop point” alarm message using start.
- 

### NOTICE

With the **AXIS-H EMC** mineral fertiliser spreader (not for AXIS-H 30.2 EMC and AXIS-H 50.2 EMC), the emergency actuation must not lock the drop point adjustment. Otherwise, the drop point setting unit may be damaged.

---

#### 4.4.5 Calibration



#### NOTICE

The **Calibration start** menu is locked in the **AUTO km/h + AUTO kg** operating mode for all weighing spreaders and for all machines. This menu point is inactive.

In this menu, the flow factor can be determined based on a calibration and saved in the machine control unit.

Execute the calibration:

- before spreading for the first time.
- if the fertiliser quality has changed significantly (moisture, high dust content, granulate damage).
- if a new fertiliser type is used.

The calibration must either be conducted with a running PTO at a standstill or while driving over a test section.

- Remove both spreading discs.
- Move the drop point to the calibration position (value 0).

#### Entering the working speed:

1. Open the **Fertiliser settings > Calibration start** menu.
2. Enter the average working speed.  
This value is required for calculating the slide position during the calibration.
3. Press **Next**.
  - ▷ The new value is saved in the machine control unit.
  - ▷ The second calibration page is displayed.



#### Selecting the section:

4. Determine the spreading side on which you wish to conduct the calibration.
    - Press the function key of the **Left** spreading side or
    - Press the function key of the **Right** spreading side.
- ▷ **The symbol indicating the selected spreading side has a red background.**

**▲ WARNING**



**Risk of injury during calibration**

Rotating machine components and ejected fertiliser may cause injury.

- ▶ **Before starting** the calibration, it is to be ensured that all preconditions have been met.
- ▶ Observe the **calibration** chapter in the operating manual of the machine.



**5. Press Start/Stop.**

- ▷ The metering slide of the previously selected section opens and the calibration is started.

**NOTICE**

The calibration can be stopped at any time by pressing the **ESC** key. The metering slide is closed and the **Fertiliser settings** menu is displayed.

**NOTICE**

The calibration time is not relevant to the accuracy of the results. However, a **minimum of 20 kg** should be calibrated.

**6. Press Start/Stop again.**

- ▷ The calibration is finished.
- ▷ The metering slide will be closed.
- ▷ The third page of the calibration is displayed.

**New calculation of the flow factor**

**▲ WARNING**



**Risk of injury due to rotating machine components**

Any contact with rotating machine components (universal drive shaft, hubs) may lead to bruises, abrasions and crushing injuries. Body parts or objects may be caught or pulled in.

- ▶ Turn the tractor motor off.
- ▶ Switch off the hydraulic system and secure it against unauthorised activation.

7. Weigh the input collected (taking into account the empty weight of the collecting vessel).
8. Enter the weight under **Input collected weight**.
9. Press **OK**.
  - ▷ The new value is saved in the machine control unit.
  - ▷ The **Flow factor calculation** menu is displayed.

**NOTICE**

The flow factor must lie between 0.4 and 1.9.

**10. Determine the flow factor.**

For applying the **newly calculated** flow factor, press **Confirm flow factor**.

In order to confirm the **previously saved** flow factor, press the **ESC key**.

- ▷ **The flow factor is saved.**
- ▷ **At the AXIS-H EMC, the Approach drop point alarm notification is displayed.**

**▲ CAUTION****Danger of injury during the automated drop point adjustment.**

At the **AXIS-H EMC**, the **Approach drop point** alarm message is displayed. Upon actuation of the **Start/Stop** function key, the drop point is automatically moved to the pre-set value by means of the electrical actuating cylinders. This may cause injury and material damage.

- ▶ Before actuating the **Start/Stop** function key, ensure that nobody is present in the danger zone of the machine.

### 4.4.6 Boundary spreading mode

In this menu, you can select a suitable spreading mode at the field boundary.

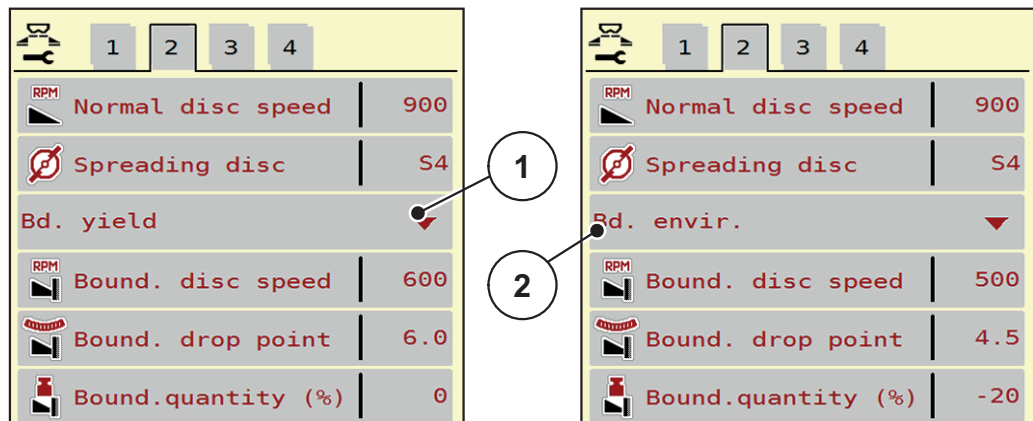

**Figure 4.6:** Boundary spreading mode settings values

- [1] Full border spreading (yield-oriented)
- [2] Limited border spreading (environment)

1. Open the **Fertiliser settings** menu.
2. Change over to tab 2.
3. Select the **border yield** or **border environment** spreading mode.
  - ▷ **Only the values** of the lower 3 setting menus will adapt to the selected mode. The **menu names** remain unchanged.
4. If required, adjust the RPM, drop point or quantity reduction in accordance with the information provided in the fertiliser chart.

### 4.4.7 Boundary quantity



In this menu, the quantity reduction can be set (as percentage value). This setting is used for the activation of the boundary spreading function.

#### NOTICE

It is recommended to reduce the quantity on the border side by 20 %.

#### Entering the boundary quantity:

1. Open the **Fertiliser settings > Boundary quantity** menu.
2. Enter the value in the input field and confirm it.
- ▷ **The fertiliser settings window with the new boundary quantity is displayed.**

### 4.4.8 Calculate OptiPoint



In the **Calculate OptiPoint** menu, you can enter the parameters to calculate the optimum switch-on and switch-off distances **in the headland**.

The input of the distance factor for the used fertiliser is crucial for the correct calculation.

**NOTICE**

The distance factor for the used fertiliser can be obtained from the fertiliser chart of your machine.

1. In the **Fertiliser settings > Distance factor** menu, enter the value from the provided fertiliser chart.
2. Open the **Fertiliser settings > Calculate OptiPoint** menu.
  - ▷ The first page of the **Calculate OptiPoint** menu is displayed.

**NOTICE**

The indicated forward speed refers to the forward speed in the area of the switching positions! Refer to chapter [5.9: GPS-Control, page 85](#)

3. Enter **the average forward speed** in the range of switching positions.
  - ▷ The second page of the menu is displayed.
4. Press **OK**.
5. Press **Next**.
  - ▷ The third page of the menu is displayed.

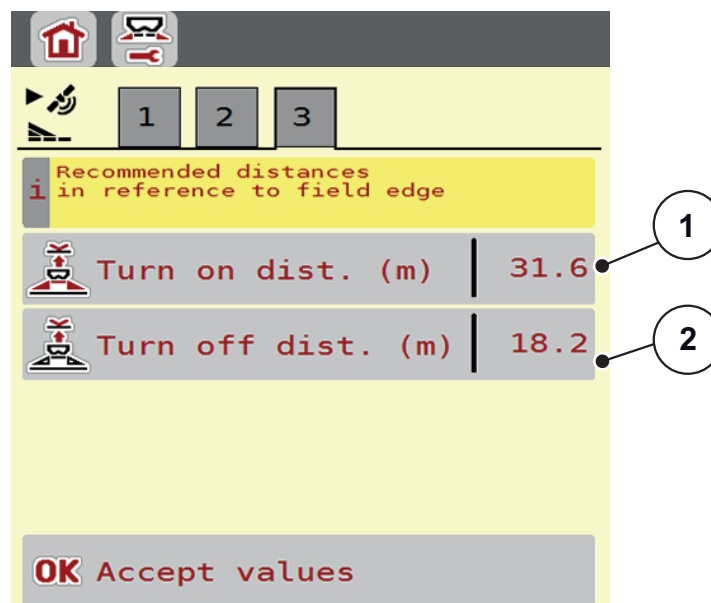

Figure 4.7: Calculate OptiPoint, page 3

Number	Meaning	Description
1	Distance (in meters) in reference to the field border from which the metering slides open	<a href="#">Page 86</a>
2	Distance (in meters) in reference to the field border from which the metering slides close.	<a href="#">Page 87</a>

### NOTICE

On this page, you can manually adjust the parameters. Refer to chapter [5.9: GPS-Control, page 85](#).

---

#### Changing the values

6. Open the desired list entry.
  7. Enter the new values.
  8. Confirm the input by pressing **Enter**.
  9. Press **Accept values**.
- ▷ **The OptiPoint has been calculated.**
  - ▷ **The machine control unit switches to the GPS-Control Info window.**



#### 4.4.9 GPS-Control Info



In the **GPS-Control Info** menu, information on the calculated settings values in the **Calculate OptiPoint** menu can be obtained.

According to the used terminal 2 distance values (CCI, Müller Elektronik) or 1 distance and 2 times values (John Deere, ...) are displayed

- Enter the values displayed here **manually** in the respective settings menu of the GPS terminal.

#### NOTICE

This menu is for information purposes only.

- Observe the operating manual of your GPS terminal.

1. Open the **Fertiliser settings > GPS-Control Info** menu.

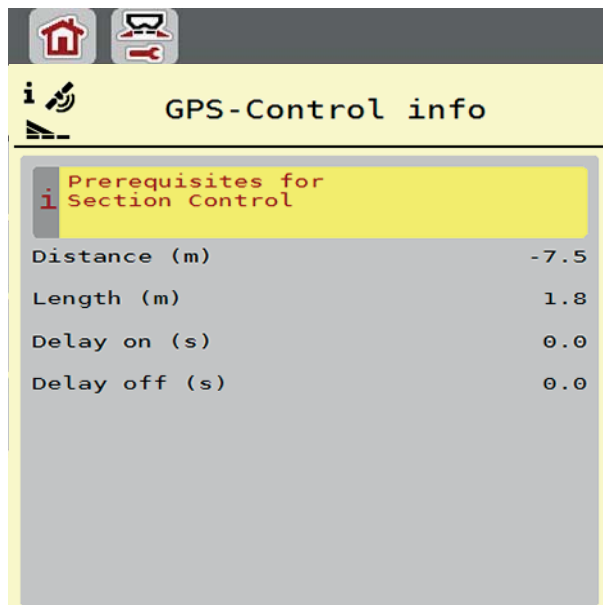

**Figure 4.8:** GPS-Control Info menu

4.4.10 Fertiliser charts



In this menu, you can create and manage your own **Fertiliser charts**.

**NOTICE**

Selecting a fertiliser chart has an effect on the fertiliser settings, the machine control unit and the mineral fertiliser spreader. The set application rate is overwritten by the stored value from the fertiliser chart.

**NOTICE**

You will be able to automatically manage fertiliser charts with your PC and to transfer them from your ISOBUS terminal if you have the **FertChart app** installed.

- Contact your dealer to install the FertCart app on your ISOBUS terminal.

**Creating a new fertiliser chart**

You will be able to create up to **30** fertiliser charts in the electronic machine control unit.

1. Open the **Fertiliser settings > Fertiliser charts** menu.

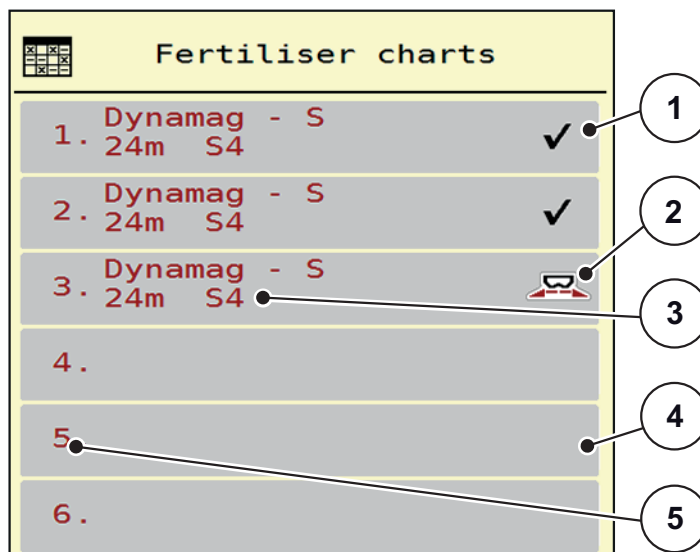

**Figure 4.9:** Fertiliser charts menu

- [1] Display for a fertiliser chart filled with values
- [2] Display for an active fertiliser chart
- [3] Fertiliser chart name field
- [4] Empty fertiliser chart
- [5] Chart number

2. Select an empty fertiliser chart.  
The **name field** includes the fertiliser name, the working width and the disc type.  
▷ The display shows the selection window.
3. Press the **Open and return...** option.  
▷ The **Fertiliser settings** menu is displayed and the selected element is loaded into the fertiliser settings as **Active fertiliser chart**.
4. Select the **Fertiliser name** menu entry.
5. Enter the name for the fertiliser chart.

#### **NOTICE**

We recommend giving the fertiliser chart the name of the fertiliser. This way, specific fertilisers can be assigned to fertiliser charts more easily.

6. Edit the parameters of the **fertiliser chart**.  
Refer to chapter [4.4: Fertiliser settings, page 31](#).

#### **Selecting a fertiliser chart:**

1. Open the **Fertiliser settings > Fertiliser chart** menu.
2. Select the desired fertiliser chart.  
▷ The display shows the selection window.
3. Select the **Open and return...** option.  
▷ **The fertiliser settings menu is displayed and the selected element is loaded into the fertiliser settings as active fertiliser chart.**

#### **NOTICE**

When selecting an existing fertiliser chart, all values in the **fertiliser settings** menu will be overwritten with the stored values obtained from the selected fertiliser chart, including the drop point and the normal spreading speed.

- The machine control unit will move the actuators of the drop point to the value stored in the fertiliser chart.

#### **Copying an existing fertiliser chart**

1. Select the desired fertiliser chart.  
▷ The display shows the selection window.
2. Select the **Copy element** option.  
▷ **A copy of the fertiliser chart is now on the first free position of the list.**

### Deleting an existing fertiliser chart

#### NOTICE

The active fertiliser chart **cannot** be deleted.

1. Select the desired fertiliser chart.
  - ▷ The display shows the selection window.
2. Select the **Delete element** option.
  - ▷ **The fertiliser chart is deleted from the list.**

### Managing the selected fertiliser chart via the operating screen

You can also manage the fertiliser chart directly via the operating screen.

1. Press the fertiliser chart [2] button on the touch screen.
  - ▷ The active fertiliser chart is displayed.

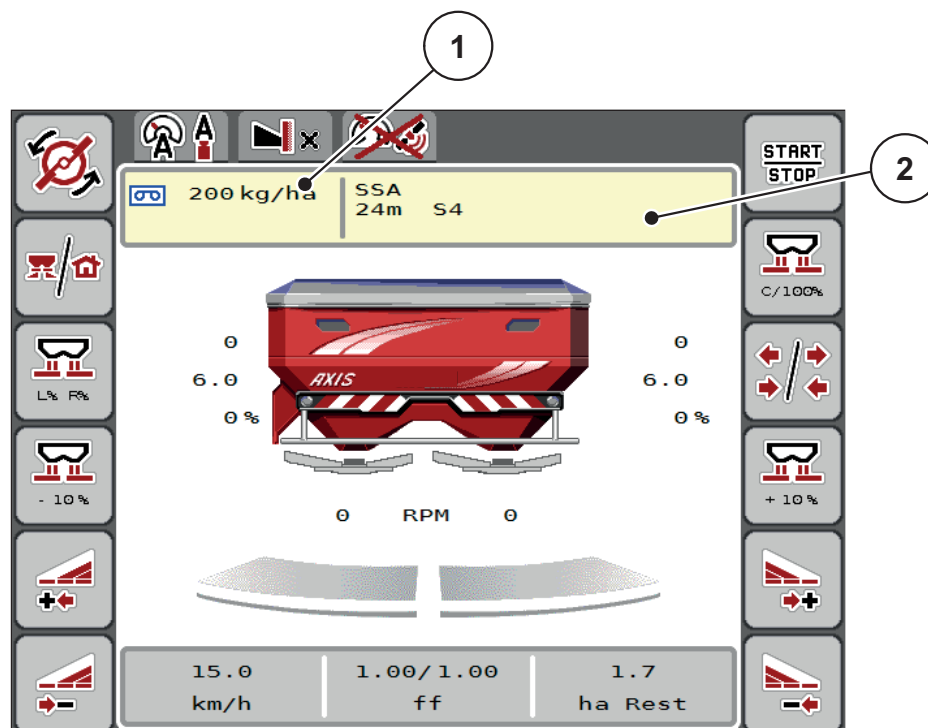

**Figure 4.10:** Managing the fertiliser chart via the touch screen

- [1] Application rate button
- [2] Fertiliser chart button

2. Enter the new value in the input field.
3. Press **OK**.
  - ▷ **The new value is saved in the machine control unit.**

### 4.5 Machine settings



You can adjust the settings for the tractor and machine in this menu.

- Open the **Machine settings** menu.

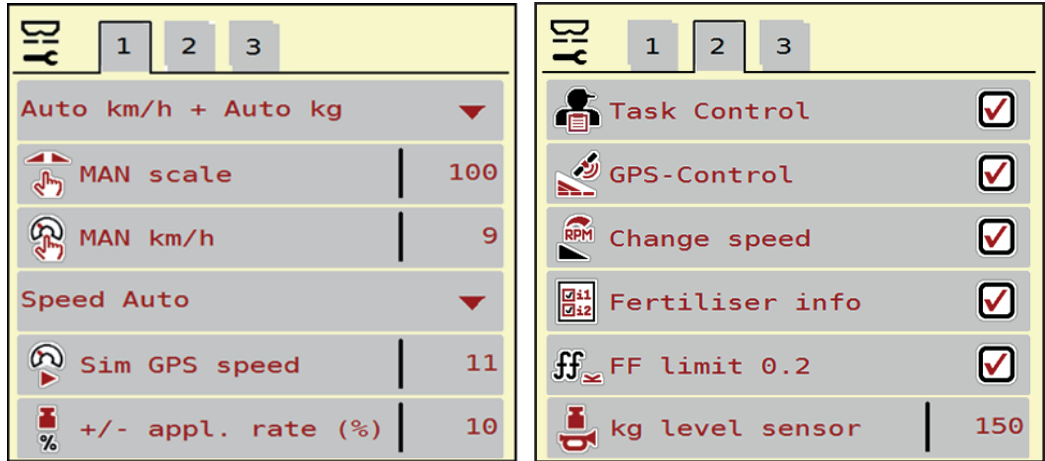

Figure 4.11: Machine settings menu, tab 1 and 2

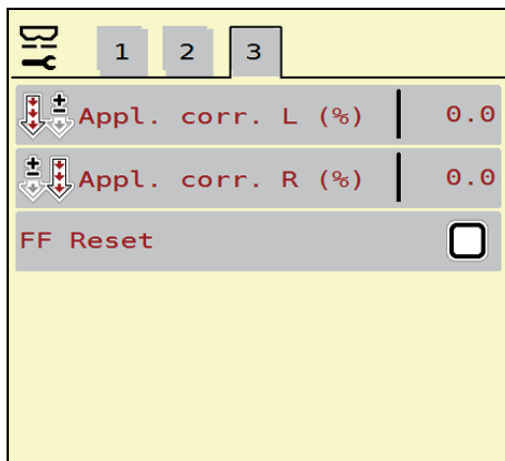

Figure 4.12: Machine settings menu, tab 3

**NOTICE**

Not all parameters are displayed simultaneously on screen. The **Arrow keys (left/right)** enable a change over to the adjacent menu window (tab).

Sub-menu	Meaning	Description
Operating mode	Determining the automatic or manual operating mode.	<a href="#">Page 50</a>
MAN scale	Setting the manual scale value. (only influences the respective operating mode)	To be entered in a separate input window.

Sub-menu	Meaning	Description
MAN km/h	Setting the manual speed. (only influences the respective operating mode)	To be entered in a separate input window.
Forward speed/Signal source	Selection/limitation of the speed signal <ul style="list-style-type: none"> <li>• Speed Auto (automated selection of either gear or radar/GPS<sup>1</sup>)</li> <li>• GPS J1939<sup>1</sup></li> </ul>	
Sim GSP speed	<b>Only for GPS J1939:</b> Indication of forward speed in the event of a loss of the GPS signal	<b>NOTE!</b> The indicated forward speed is to be maintained constantly at all times.
+/- application rate (%)	Pre-setting the quantity adjustment for the different spreading types.	To be entered in a separate input window.
Task Control	Activation of the ISOBUS Task Controller functions for documentation and for application map spreading. <ul style="list-style-type: none"> <li>• Task Control on (checked)</li> <li>• Task Control off</li> </ul>	
GPS-Control	Activation of the function to control the machine sections via a GPS-Control unit. <ul style="list-style-type: none"> <li>• GPS-Control AUTO (checked)</li> <li>• GPS-Control Off</li> </ul>	
Change disc speed	Activation of the function for modifying the speed in the boundary spreading mode in the operating screen.  If this function is deactivated, the modification may only be implemented as a percentage value (%).	
Fertiliser information	Activation of the fertiliser information (fertiliser name, disc type, working width) in the operating screen.	
FF limit 0.2	Extension of the flow factor range from 0.4 to 0.2.  Application: <ul style="list-style-type: none"> <li>• Organic fertiliser</li> <li>• Rice</li> </ul>	

Sub-menu	Meaning	Description
kg level sensor	Input of the remaining quantity to trigger an alarm message via the weigh cells.	
Application rate correction L/R (%)	Correction of the deviations between the entered application rate and the actual application rate. <ul style="list-style-type: none"> <li>● Correction in percent either on the right or left side</li> </ul>	
FF Alarm Re-set	Box checked: In case of an alarm the machine control unit will set the flow factor to the value stored in the fertiliser chart.	<a href="#">Page 78</a>

1. RAUCH shall not be liable in the event of a loss of the GPS signal.

### 4.5.1 AUTO/MAN mode

The machine control unit automatically controls the dosing quantity according to the speed signal. Here, the application rate, working width and flow factor are taken into account.

By default, the unit is operated in the **automatic** mode.

The **manual** mode is only applied if:

- there is no speed signal (radar or wheel sensor not available or defective),
- slug pellets or seeds are spread (fine seeds).

**NOTICE**

For a regular spreading of the spreading material, it is imperative to work with a **constant forward speed** in manual operating mode.

---

**NOTICE**

Spreading work with different operating modes is described in chapter [5: Spreading with the machine control unit AXIS-H ISOBUS, page 71](#).

---

Menu	Meaning	Description
AUTO km/h + AUTO kg	Selecting the automatic mode with automatic weighing	<a href="#">Page 77</a>
AUTO km/h	Selecting the automatic mode	<a href="#">Page 81</a>
MAN scale	Metering slide adjustment for manual mode	<a href="#">Page 82</a>
MAN km/h	Adjustment of forward speed for manual mode	<a href="#">Page 83</a>

#### Selecting the operating mode

1. Switch on the AXIS-H ISOBUS machine control unit.
2. Open the **Machine settings > AUTO/MAN mode** menu.
3. Select the desired menu entry from the list.
4. Press **OK**.
5. Follow the instructions on screen.

**NOTICE**

It is recommended to have the flow factor displayed in the operating screen. By doing so, you can observe the mass flow control during spreading. Please refer to chapter [2.4.3: Display of the metering slide status, page 14](#) and chapter [4.5.1: AUTO/MAN mode, page 50](#).

---

- Important information on the use of operating modes for spreading is provided in chapter [5: Spreading with the machine control unit AXIS-H ISOBUS, page 71](#).



#### 4.5.2 +/- application rate



In this menu, you can set the step width of the percentage **quantity adjustment** for normal spreading.

The pre-set value of the metering slide opening serves as basis (100%).



#### NOTICE

During operation, the **Quantity +/ Quantity -** function keys can be used to adjust the application rate by the **+/- Quantity** factor at any time.

The pre-configuration can be restored with the **C 100 % key**.

#### Specifying the quantity reduction:

1. Open the **Machine settings > +/- application rate (%)** menu.
2. Enter the percentage by which you wish to modify the spreading quantity.
3. Press **OK**.

## 4.6 Fast emptying



In order to quickly clean the machine after the spreading work or to quickly empty any residual quantities, the **Fast emptying** menu can be selected.

For this purpose, before storing the machine, we recommend **completely opening** the metering slides via the fast emptying function and switching off the AXIS-H ISOBUS in this state. By doing so, you can prevent accumulation of moisture in the hopper.

### NOTICE

**Before starting** the fast emptying process, it is to be ensured that all preconditions have been met. Observe the operating instructions for the mineral fertiliser spreader (discharging the remaining quantity).

#### Carrying out the fast emptying process:

1. Open the **Main menu > Fast emptying** menu.

### CAUTION



#### Risk of injury due to automatic drop point adjustment

At the **AXIS-H EMC**, the **Approach drop point** alarm notification appears. Upon actuation of the **Start/Stop** function key, the drop point automatically moves to the pre-set value by means of the electrical actuating cylinders. Upon completion of the calibration, the system automatically moves to the drop point by means of electrical actuating cylinders. This may cause injury and material damage.

- Before actuating the **Start/Stop** key, ensure that **nobody** is present in the danger zone of the machine.

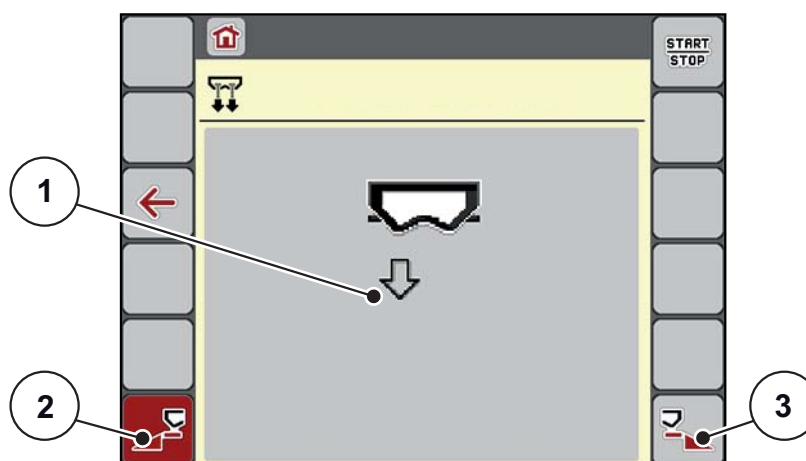

**Figure 4.13:** Fast emptying menu

- [1] Symbol for fast emptying (here: left side selected, not started)
- [2] Fast emptying, left section (selected)
- [3] Fast emptying, right section (not selected)

2. Press the **Function key** to select the section for which the fast emptying function is to be carried out.
  - ▷ The selected section is displayed as symbol ([figure 4.13](#), position [2]).
3. **Press Start/Stop.**
  - ▷ The fast emptying process starts.
4. **Press Start/Stop** once the hopper is empty.
  - ▷ The fast emptying process is completed.
5. **Press ESC** to return to the **Main menu**.

**▲ CAUTION****Risk of injury due to automatic drop point adjustment**

At the **AXIS-H EMC**, the **Approach drop point** alarm message appears. Upon actuation of the **Start/Stop** function key, the drop point automatically moves to the pre-set value by means of the electrical actuating cylinders. This may cause injury and material damage.

- ▶ Before actuating the **Start/Stop** key, ensure that **nobody** is present in the danger zone of the machine.

4.7 System/Test



In this menu, the system and test settings for the machine control unit can be configured.

- Open the **Main menu > System/test** menu.

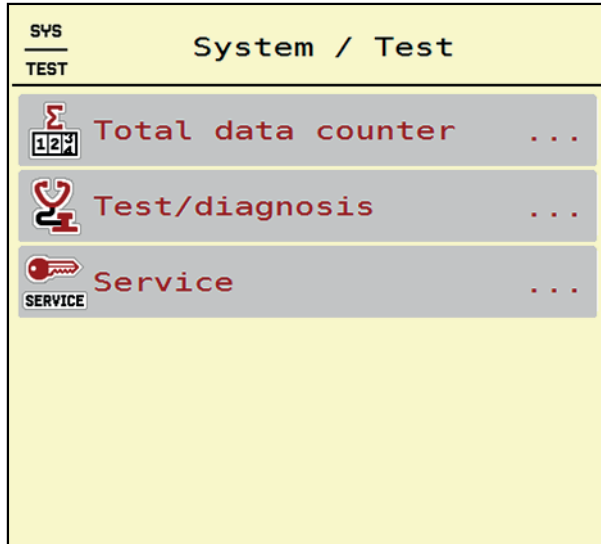

Figure 4.14: System/test menu

Sub-menu	Meaning	Description
Total data counter	Display of total <ul style="list-style-type: none"> <li>• spread quantity in kg</li> <li>• spread area in ha</li> <li>• spread time in h</li> <li>• distance travelled in km</li> </ul>	<a href="#">Page 55</a>
Test/diagnosis	Checking of actuators and sensors.	<a href="#">Page 56</a>
Service	Service settings	Password-protected; only accessible for service personnel

4.7.1 Total data counter



In this menu, all of the spreader's counter readings are displayed.

- spread quantity in kg
- spread area in ha
- spread time in h
- distance travelled in km

**NOTICE**

This menu is for information purposes only.

<div style="display: flex; align-items: center;"> <div style="margin-right: 10px;"> <math>\Sigma</math>  <span style="font-size: small;">1 2 3 4</span> </div> <div> <b>Total data counter</b> </div> </div>	
kg calculated	712168
ha	1902.4
hours	93
km	673

**Figure 4.15:** Total data counter menu

4.7.2 Test/diagnosis



In the **Test/diagnosis** menu, you can check the functions of all actuators.

**NOTICE**

This menu is for information purposes only.

The list of sensors depends on the equipment of the machine.

**⚠ CAUTION**



**Risk of injury due to moving machine parts.**

During the tests, machine parts may start to move automatically.

- ▶ Ensure that nobody is present in the area of the mineral fertiliser spreader before carrying out the tests.

Sub-menu	Meaning	Description
Voltage	Checking the operating voltage.	
Metering slider	Manual movement of actuators.	<a href="#">Page 57</a>
Test points slider	Test for approaching the various position points of the slides.	Checking the calibration
Drop point	Manual movement of actuators.	
Test points	Approaching the drop point.	Checking the calibration
LIN Bus	Checking the communication of the drop point cylinders.	<a href="#">Page 58</a>
Spreading disc	Manual activation of the spreading discs.	
Agitator	Checking of the agitator.	
Pressure sensor	Checking the pressure sensors	
Weigh cells	Checking the sensors.	
Level sensors	Checking the sensor.	
Hopper cover	Checking the actuators.	

**Example for metering slide test/diagnosis**

1. Open the **Test/diagnosis > Metering slider** menu.
- ▷ **The status of the sensors/actuators is displayed.**

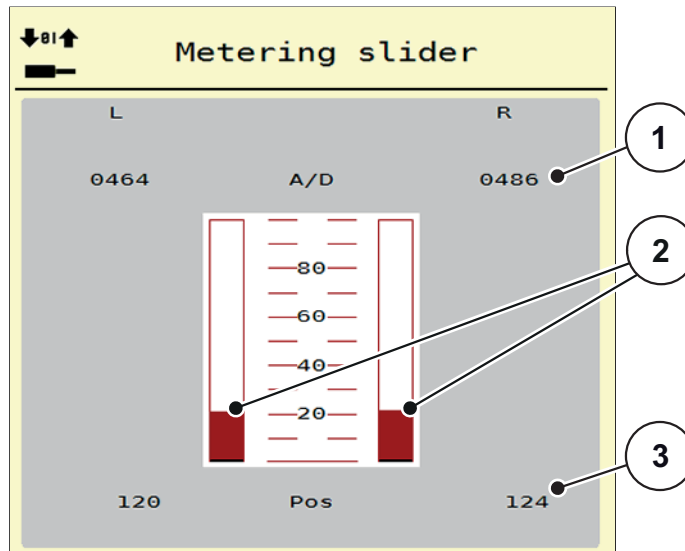

**Figure 4.16:** Test/diagnosis, example: Metering slide actuator

- [1] Signal display
- [2] Signal bargraph
- [3] Position display

Under **Signal**, the status of the electrical signal for the left and right sides is separately displayed.

**⚠ CAUTION**



**Risk of injury due to moving machine parts**

During the tests, machine parts may start to move automatically.

- ▶ Ensure that nobody is present in the area of the machine before carrying out the tests.

The actuators can be extended and retracted upwards and downwards by pressing the corresponding arrow keys.

**Example: LIN bus**

1. Open the **System/Test > Test/Diagnosis** menu.
2. Select the **LIN bus** menu item.
  - ▷ The status of the actuators/sensors is displayed.

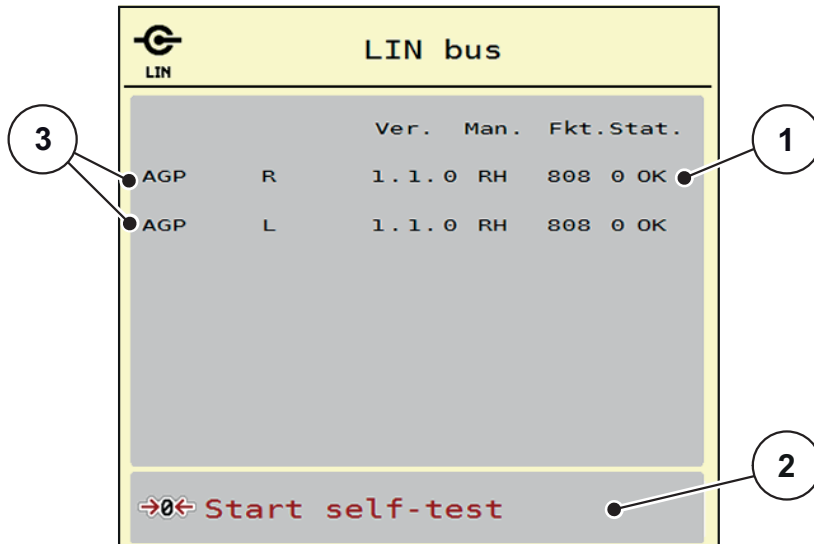

**Figure 4.17:** Test/Diagnosis; example: LIN bus

- [1] Status display
- [2] Start self-test
- [3] Connected actuators

**LIN bus participant status notification**

The actuators are in different conditions:

- 0 = OK; no actuator error
- 2 = blockage
- 4 = overload

**▲ CAUTION**



**Risk of injury due to moving machine parts.**

During the tests, machine parts may start to move automatically.

- ▶ Ensure that nobody is present in the area of the machine before carrying out the tests.

**4.7.3 Service**



**NOTICE**

An input code is required to adjust the settings in the **Service** menu. These settings can **only** be modified by authorised service personnel.



### 4.8 Information



The **Information** menu provides information on the control unit.

**NOTICE**

This menu provides information on the configuration of the machine.  
The information list depends on the equipment of the machine.

 Info	
S/N	23667
Software ver.	4.00.00
Hardware version	031/ 003
Actuator type	RH03
Curve correction	0
EMC factor	0.07721
Weigh cells	✓
Level sensor	

**Figure 4.18:** Info menu

## 4.9 Weighing trip counter



This menu provides values regarding spreading work carried out and functions for weighing operation.

- Open the **Main menu > Weighing trip counter** menu.
  - ▷ The **Weighing trip counter** menu is displayed.

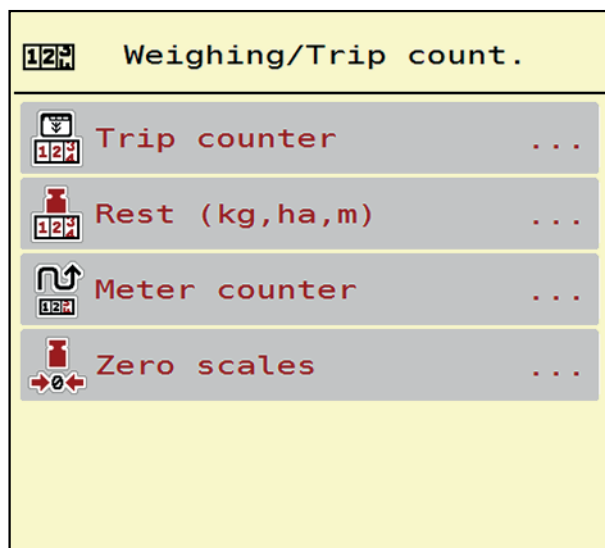

**Figure 4.19:** Weighing trip counter menu

Sub-menu	Meaning	Description
Trip counter	Display of the applied spreading quantity, area spread and spread distance.	<a href="#">Page 61</a>
Rest (kg, ha, m)	For weighing spreaders only: Display of the remaining quantity in the hopper.	<a href="#">Page 62</a>
Metre counter	Display of the distance travelled since the last reset of the metre counter.	Reset (zeroing) by pressing the <b>C 100 % key</b>
Zero scales	For weighing spreaders only: The weighing value for empty scales is set to "0kg".	<a href="#">Page 63</a>

### 4.9.1 Trip counter



In this menu, the values of the spreading work realized can be obtained, the remaining spreading quantity can be observed and the trip counter can be reset by clearing.

- Open the **Weighing trip counter > Trip counter** menu.
  - ▷ The **Trip counter** menu appears.

During the spreading work, i.e. with the metering slides being open, you can change into the **Trip counter** menu and obtain the current values there.

**NOTICE**

If you wish to continuously observe the values during the spreading work, you may also assign the freely selectable display fields on the operating screen to **kg Trip**, **haTrip** or **mTrip**, see [2.4.2: Display fields, page 12](#).

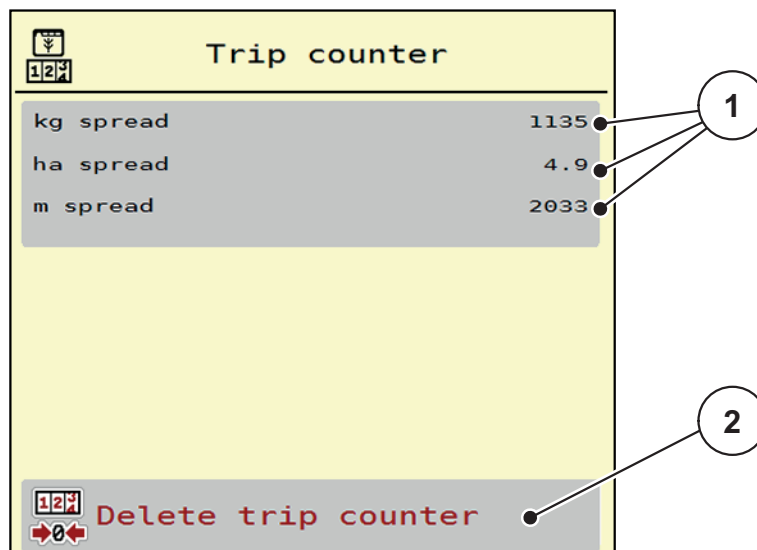

**Figure 4.20:** Trip counter menu

- [1] Spread quantity, area and distance display fields
- [2] Clear trip counter entry

**Clearing the trip counter:**

1. Open the **Weighing trip counter > Trip-counter** sub-menu.
  - ▷ The calculated values for spread quantity, area and distance **since the last clearing** are displayed.
2. Press **Delete trip counter**.
  - ▷ **All values of the trip counter are reset to 0.**

4.9.2 Rest (ka, ha, m)



In the **kg left** menu, you can obtain the **remaining quantity** in the hopper. The menu indicates the possible **area (ha)** and **distance (m)** which can still be spread with the remaining fertiliser quantity.

- Open the **Weighing trip counter > Rest (kg, ha, m)** menu.
  - ▷ The **Rest** menu appears.

**NOTICE**

For **weighing spreaders** the current loading weight can only be determined by weighing. In all other spreaders, the remaining fertiliser quantity is calculated from the fertiliser and machine settings as well as from the drive signal, and the filling quantity is to be entered manually (see below).

The **Application rate** and **Working width** values cannot be changed in this menu. They are for information purposes only.

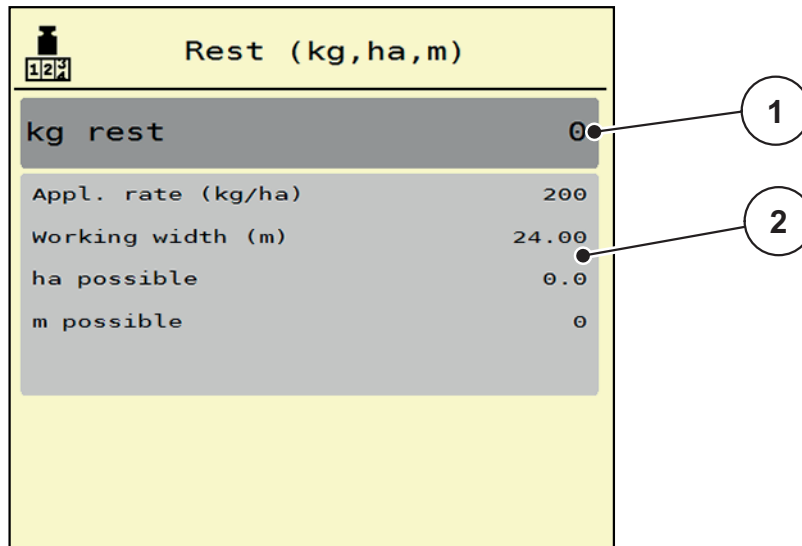

**Figure 4.21:** Rest menu

- [1] Remaining quantity input window (kg)
- [2] Application rate, working width, possible spread area and distance display fields

For machines without weigh cells

1. Fill the hopper.
2. In the **kg left** area, enter the total weight of the fertiliser left in the hopper.
  - ▷ The unit calculates the values for the possible spread area and distance.

### 4.9.3 Tare the scales (weighing spreader only)



In this menu, the weighing value for the empty hopper is to be set to 0 kg.

For taring the scales, the following requirements have to be fulfilled:

- the hopper is empty,
- the machine is at a standstill,
- the PTO shaft is switched off,
- the machine is in a horizontal position and off the ground,
- the tractor is at a standstill.

#### **Taring the scales:**

1. Open the **Weighing trip counter > Zero scales** menu.

2. Press **Zero scales**.

▷ **The weighing value for the empty scale is now set to 0 kg.**

#### **NOTICE**

Tare the scale before each use in order to ensure a problem-free calculation of the remaining quantity.

4.10 Hopper cover



**⚠ WARNING**



**Danger of crushing and shearing due to components operated by an external force**

The hopper cover will move without warning and can cause personal injury.

- ▶ Ensure that nobody is present in the hazard zone.

The AXIS-H EMC is equipped with an electrically operated hopper cover. During the refilling process at the end of the field, you can open and/or close the hopper cover via the control unit and a electrical drive.

**NOTICE**

The menu is used for activating the actuators for opening and/or closing the hopper cover exclusively. The machine control unit AXIS-H ISOBUS does not detect the exact position of the hopper cover.

- Observe the movements of the hopper cover.

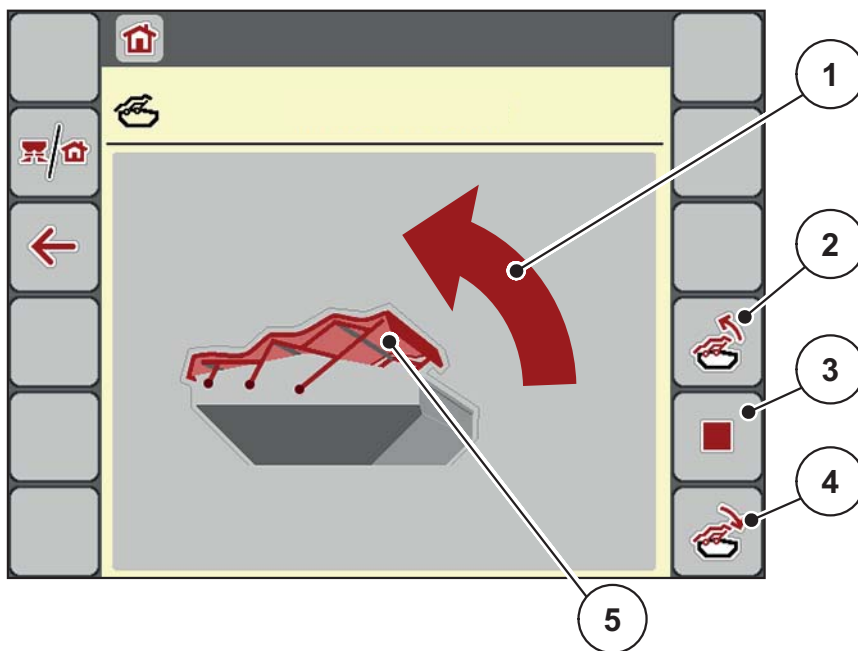

**Figure 4.22:** Hopper cover menu

- [1] Display of opening process
- [2] Open hopper cover
- [3] Stop process
- [4] Close hopper cover
- [5] Static display of hopper cover

**▲ CAUTION****Material damage due to insufficient clearance**

Opening and closing the hopper cover requires a sufficient clearance above the hopper. If the clearance is insufficient, the hopper cover may tear. The rods of the hopper cover may be damaged and the hopper cover may damage the environment.

- ▶ Ensure that a sufficient clearance above the hopper cover is given.

**Moving the hopper cover**

1. Press the **Menu** button.
2. Open the **Hopper cover** menu.
3. Press the **Open hopper cover** key.
  - ▷ During the movement, an arrow appears which indicates the **OPEN** direction.
  - ▷ The hopper cover will open entirely.
4. Fill in the fertiliser.
5. Press the **Close hopper cover** key.
  - ▷ During the movement, an arrow appears which indicates the **CLOSED** direction.
  - ▷ The hopper cover will be closed.



If required, you can stop the movement of the hopper cover by pressing the **Stop**-key. The hopper cover remains in the intermediate position until you close or open it entirely again.

## 4.11 Special functions

### 4.11.1 Text input

In some menus, it is possible to enter freely editable text; for this purpose, 2 different input windows are displayed.



Figure 4.23: Alphanumeric input



Figure 4.24: Numerical input

1. Enter the desired text or the desired value via the keyboard.
2. Press **OK**.
  - ▷ The text will be stored in the machine control unit.
  - ▷ The display shows the previous selection window.
3. Cancel the input by pressing the **ESC** key.
  - ▷ The display shows the previously selected menu.



### 4.11.2 Selection window

Some menus include selection windows.

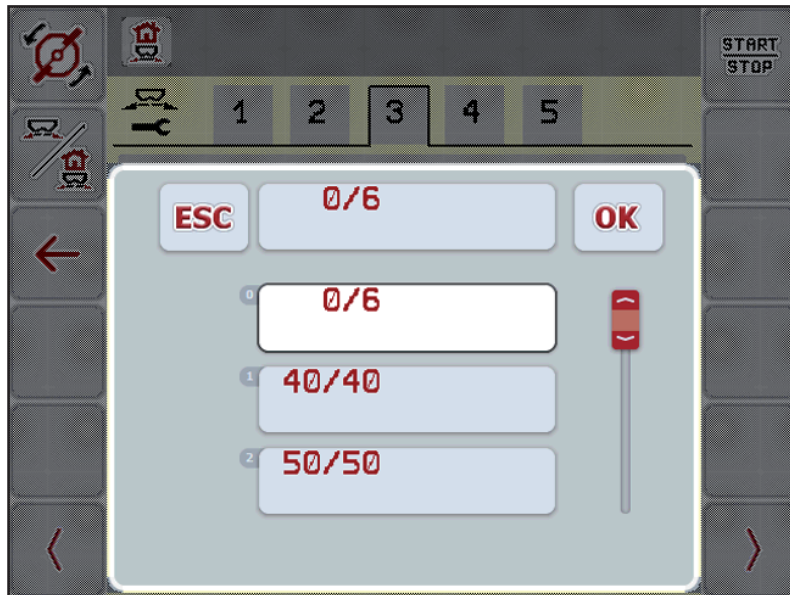

**Figure 4.25:** Selection window

1. Select the desired entry in the selection window.
2. Press **OK**.
  - ▷ The selection will be stored.
  - ▷ The display shows the previous selection window.
3. Cancel the input by pressing the **ESC** key.
  - ▷ The display shows the previously selected menu.

4.11.3 Using the joystick

As an alternative to the settings in the operating screen of the ISOBUS terminal, you may also use a joystick. See [7: Optional equipment, page 93](#). The joystick offered by RAUCH is pre-programmed with specific functions at the factory.

**NOTICE**

If you wish to use a different joystick, please contact your dealer.

- Only your dealer will be able to programme the keys for the joystick in your ISOBUS terminal.

**Key assignment of the WTK joystick**

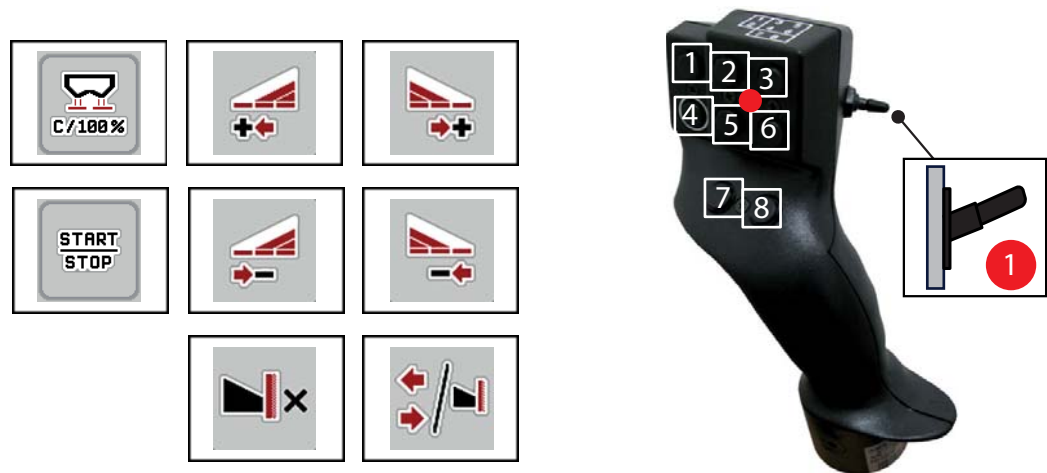

**Figure 4.26:** Key assignment, level 1 (LED is red)

- [1] Reset
- [2] Increase section, left
- [3] Increase section, right
- [4] Start/stop application rate regulation
- [5] Reduce section, left (minus)
- [6] Reduce section, right (minus)
- [7] Switch over between limited (environment)/full border (yield) spreading mode
- [8] Switch over between sections/boundary spreading

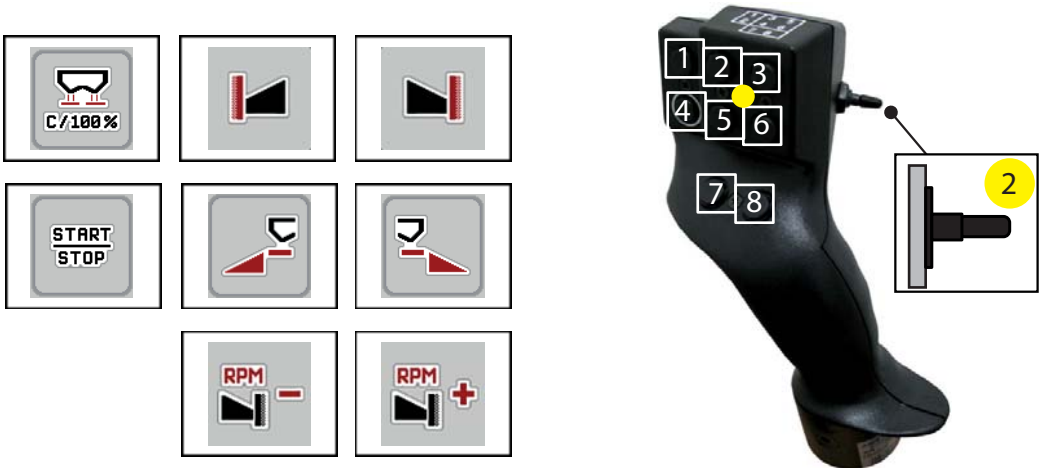

**Figure 4.27:** Key assignment, level 2 (LED is yellow)

- [1] Reset
- [2] Boundary spreading on the left spreading side
- [3] Boundary spreading on the right spreading side
- [4] Start/stop application rate regulation
- [5] Activate left spreading side
- [6] Activate right spreading side
- [7] Reduce the spreading disc speed
- [8] Increase the spreading disc speed



**Figure 4.28:** Key assignment, level 3 (LED is green)

- [1] Reset
- [2] Increase quantity, left
- [3] Increase quantity, right
- [4] Start/stop application rate regulation
- [5] Reduce quantity, left
- [6] Reduce quantity, right
- [7] Reduce quantity on both sides
- [8] Increase quantity on both sides



## 5 Spreading with the machine control unit AXIS-H ISOBUS

The **AXIS-H ISOBUS** machine control unit provides support for the machine settings before starting to work. During spreading, the functions of the machine control unit are also active in the background. With these functions, the quality of the fertiliser spreading can be monitored.

### 5.1 Monitoring the remaining quantity during spreading (weighing spreaders only)

During spreading, the remaining quantity is continuously recalculated and displayed.

During spreading, i.e. with the slides being open, the **Trip counter** menu can be opened to display the remaining quantity currently in the hopper.

#### NOTICE

If the values are to be permanently monitored during spreading, freely assignable display fields in the operating screen can also be assigned with the **kg left**, **ha left** or **m left** values; refer to chapter [2.4.2: Display fields, page 12](#).

#### Working with the weighed remaining quantity, refilling the hopper:

1. Tare the scales.  
Refer to chapter [4.9.3: Tare the scales \(weighing spreader only\), page 63](#).
2. Select the fertiliser type used.  
Refer to chapter [4.4.10: Fertiliser charts, page 44](#).
3. Fill the hopper.
4. Weigh the fertiliser quantity in the hopper.
5. Start your work.  
If the hopper is empty, refill it.
6. Repeat steps 3 to 5.

## 5.2 Refilling (weighing spreader only)

Requirements:

- The kg level sensor function in the Machine settings menu is active.

### NOTICE

If the menu entry is not displayed in your machine control, please contact your salesperson or customer service.

If the refill weight exceeds 400 kg, check the residual weight via the automatically displayed window.

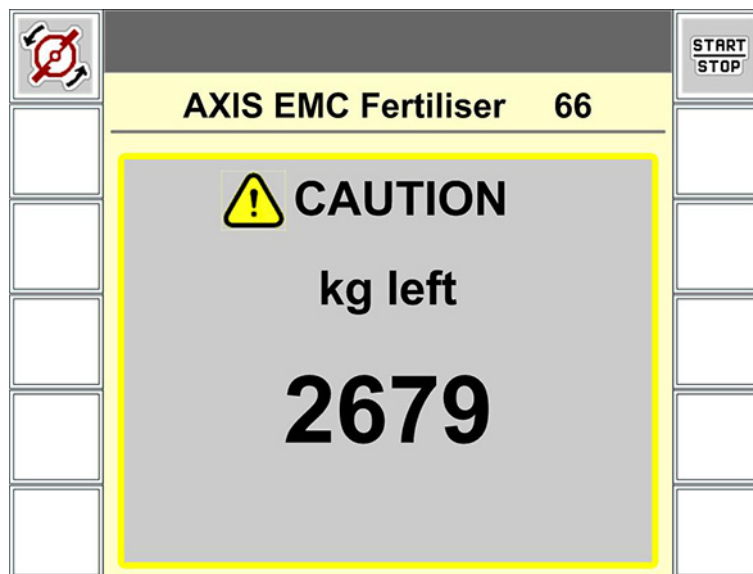

Figure 5.1: Refill weight



- Press the **ACK** foil key prior to spreading.
- Continue spreading.





When leaving the spreading area with an empty hopper, the flow factor may fall below the 0.4 limit.

- You must refill more than 400 kg to ensure the flow factor is reset to the value which was preset in the fertiliser chart.

### 5.3 Working with sections

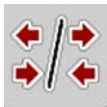
#### 5.3.1 Displaying the spreading type in the operating screen

The machine control unit offers 4 different spreading types for the spreading operation of the AXIS-H EMC machine. These settings are directly enabled in the operating screen. During the spreading operation, you can change over between the spreading types in order to ideally adapt to the field requirements.

Button	Spreading type
	Activate section on both sides
	Boundary spreading function on both sides
	Section on the left, boundary spreading function on the right possible
	Section on the right, boundary spreading function on the left possible

1. Press the toggle key several times until the desired spreading type is displayed.

#### 5.3.2 Spreading with reduced sections

You can spread with sections on one or both sides and thus adapt the entire spreading width to the field requirements. Each spreading side can be adjusted in 4 steps



- Press the **Change boundary spreading/spreading sides** key.

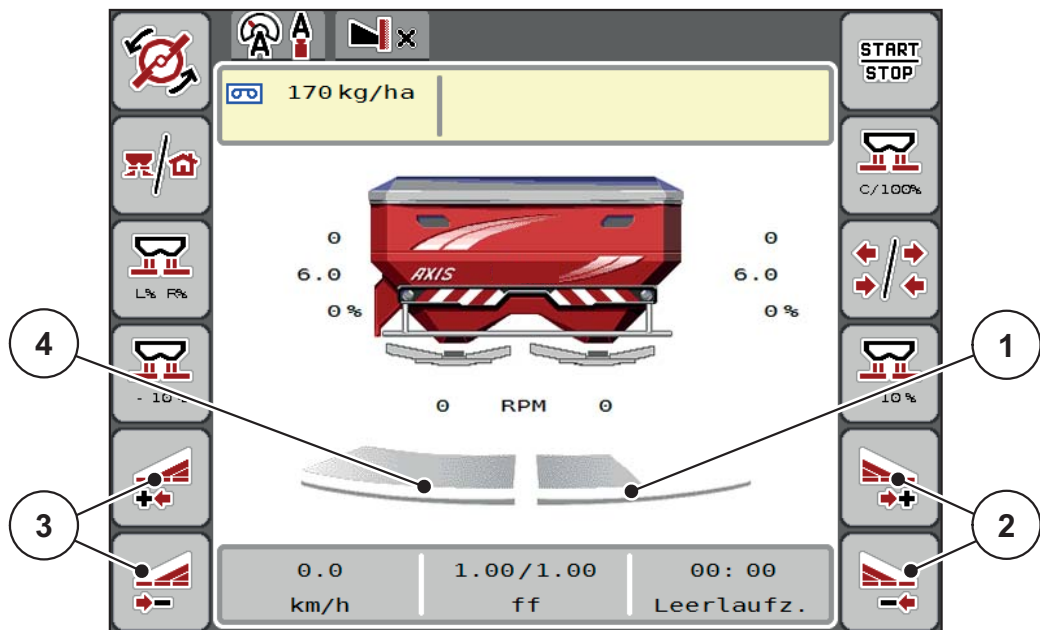

**Figure 5.2:** Operating screen, 2 sections

- [1] Right section is reduced to 2 steps
- [2] Increase or reduce right spreading width function keys
- [3] Increase or reduce left spreading width function keys
- [4] Left section will spread to the entire spreading side

**NOTICE**

- Each section can be gradually reduced or increased in 4 steps.
- **AXIS.2 only:** Section control is available from the outside to the inside or vice versa. Up to 8 sections can be reduced. Refer to [figure 5.3](#)

1. Press the **Reduce left spreading width** function key or the **Reduce right spreading width** function key.
  - ▷ The section of the spreading side will be reduced by one step.
2. Press the **Increase left spreading width** function key or the **Increase right spreading width** function key.
  - ▷ The section of the spreading side will be increased by one step.

**NOTICE**

The sections are not rated proportionally. The VariSpread spreading width assistant automatically sets the sections.



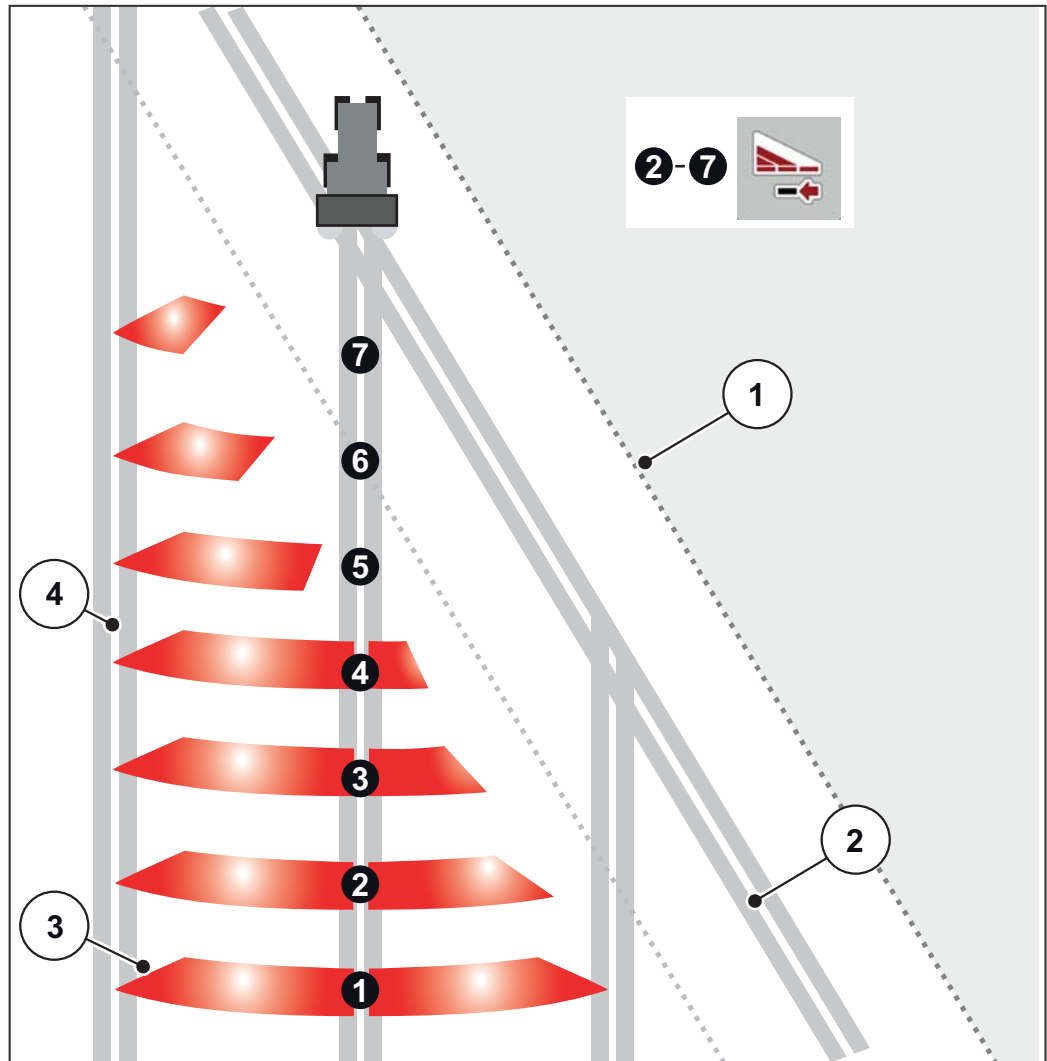

**Figure 5.3:** Automatic section control

- [1] Field border
- [2] Headlands tramline
- [3] Sections 1 to 4: successive section reduction on the right for AXIS.1 and AXIS.2.  
Sections 5 to 7: further section reduction on the right for AXIS.2
- [4] Tramline in the field

5.3.3 Spreading operation with one section and in the boundary spreading mode

During the spreading operation, the sections can be changed gradually, and boundary spreading can be activated. The figure below shows the operating screen with activated boundary spreading and activated sections.

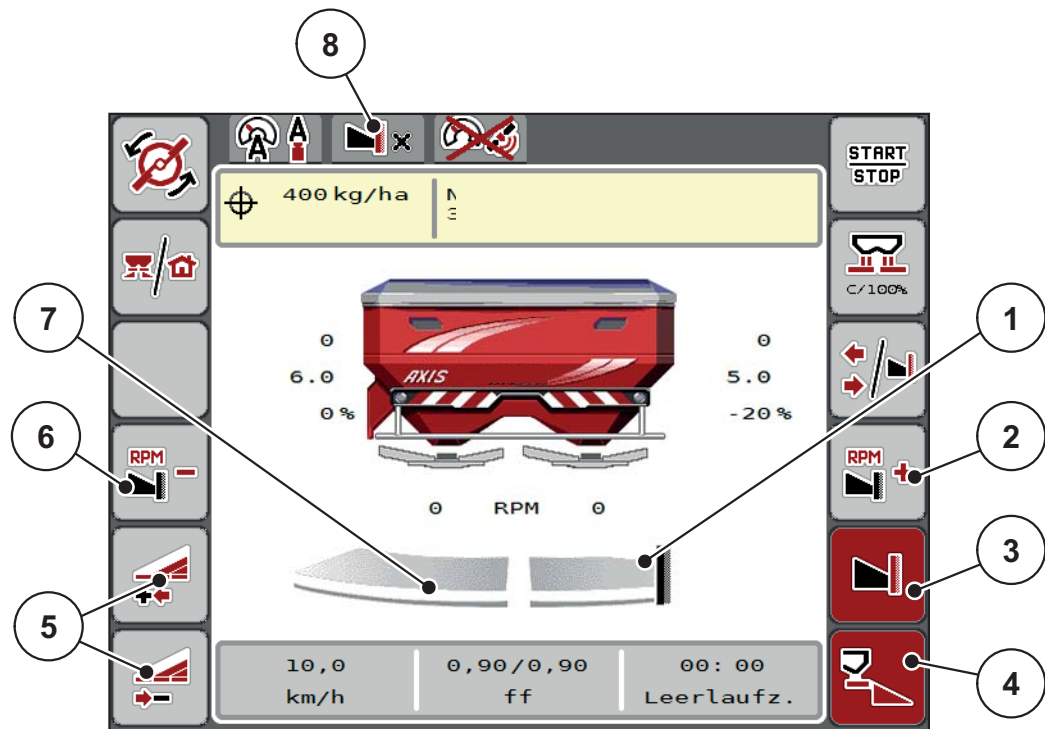

Figure 5.4: Operating screen, one section left, boundary spreading side right

- [1] Right spreading side in the boundary spreading mode
- [2] Increase the spreading disc speed on the boundary spreading side
- [3] Boundary spreading mode is activated
- [4] Right spreading side is activated
- [5] Reduce or increase left section
- [6] Reduce the spreading disc speed on the boundary spreading side
- [7] Left section adjustable in 4 steps
- [8] The current boundary spreading mode is limited border (environment).

- The spreading quantity on the left is set to the full working width.
- The **Right boundary spreading** function key has been pressed; the boundary spreading function has been activated, and the application rate has been reduced by 20 %.
- Press the **Reduce left spreading width** function key in order to reduce the section by one step.
- By pressing the **C/100%** key, you will immediately return to full working width.
- By pressing the **Right boundary spreading** function key, the boundary spreading function is deactivated.

**NOTICE**

AXIS.2 only: The limited border spreading function is also possible in automatic mode with GPS-Control.

- Refer to [page 85](#).

## 5.4 Spreading with the AUTO km/h + AUTO kg operating mode



The **AUTO km/h + AUTO kg** operating mode enables a continuous regulation of the application rate during spreading. The flow factor control is corrected at regular intervals on the basis of this information. This way, fertiliser metering can be optimised.

### NOTICE

With the **AXIS-H EMC + W** setting, the **AUTO km/h + AUTO kg** operating mode pre-set at the factory is selected by default.

#### Preconditions for spreading:

- The **AUTO km/h + AUTO kg** operating mode is active (refer to [4.5.1: AUTO/MAN mode, page 50](#)).
- The fertiliser settings are defined.
  - Application rate (kg/ha)
  - Working width (m)
  - Spreading disc type
  - Normal speed (RPM)

#### Proceed as follows:

1. Fill the hopper with fertiliser.

### ▲ WARNING



#### Risk of injury caused by ejected fertiliser

Ejected fertiliser may cause severe injury.

- ▶ Make sure no one is within the spreading zone around the fertiliser spreader before switching on the spreading discs.



2. Press **Spreading disc start**.
3. Confirm alarm notifications with the enter key. See [6.1: Meaning of the alarm messages, page 89](#).
  - ▷ The idle measurement screen is displayed.
  - ▷ The idle measurement starts automatically. See [5.5: Adaptive idle measurement, page 78](#).
4. Press **Start/Stop**.
  - ▷ **The spreading starts.**



### NOTICE

We recommend that the flow factor be displayed in the operating screen (see [2.4.2: Display fields, page 12](#)) in order to watch the flow factor regulation while spreading.

### NOTICE

In case of any problems with flow factor control (clogging, ...), at a standstill change over via the **fertiliser settings** menu and select the flow factor 1.0.

#### Resetting the flow factor

If the flow factor has fallen below the minimum value (0.4 or 0,2) alarm no. 3 appears. Refer to [6.1: Meaning of the alarm messages, page 89](#).

- In the menu **Machine settings** check the box for **FF Alarm Reset**.

After the alarm has been acknowledged, the machine control unit will set the flow factor to the value stored in the fertiliser chart.

## 5.5 Adaptive idle measurement

### 5.5.1 Automatic idle measurement

In order to achieve a high control accuracy, the EMC control must regularly measure and store the idling pressure.

The idle measurement for the determination of the idling pressure will automatically start under the following conditions:



- You have activated the spreading disc start.
- The defined period since the last idle measurement has expired.
- You have made changes in the **Fertiliser settings** menu (RPM, type of spreading disc).
- You have switched from boundary spreading to normal spreading.
- The hydraulic oil in the gearbox is too cold.

During the idle measurement, the following window appears.

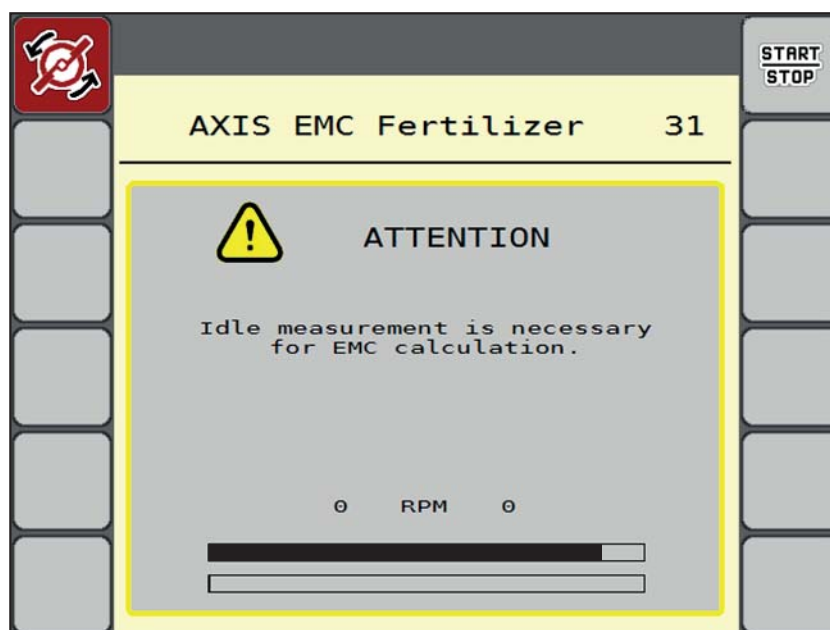

**Figure 5.5:** Idle measurement alarm display

- With the first start of the spreading disc, the machine control unit checks the oil temperature of the gearbox. As long as the oil temperature is too low, an alarm message appears and no idle measurement is possible. See [6.1: Meaning of the alarm messages, page 89](#).

#### NOTICE

If the alarm message is displayed repeatedly even though the transmission oil is warm:

- Compare the installed spreading disc with the type entered in the **Fertiliser settings** menu. Adjust, if required.
- Check the spreading disc for tight seat. Re-tighten the wheel nut
- Check the spreading disc for damage. Replace the spreading disc.

- Once the idle measurement has been completed, the machine control unit will set the idling time to 24:59 minutes in the display of the operating screen.
  - AXIS.2 only: The idle time is reset to 59:59 minutes.

#### 1. Press **Start/Stop**.

- ▷ The spreading starts.
- ▷ AXIS.1: If the metering slides are not closed during this time, a new idle measurement will start automatically after expiry of the idle time.
- ▷ AXIS.2: The idle measurement runs in the background, even if the metering slides are closed. However, no mask is shown on the display.



Once this idling period has expired, a further idle measurement is started automatically.

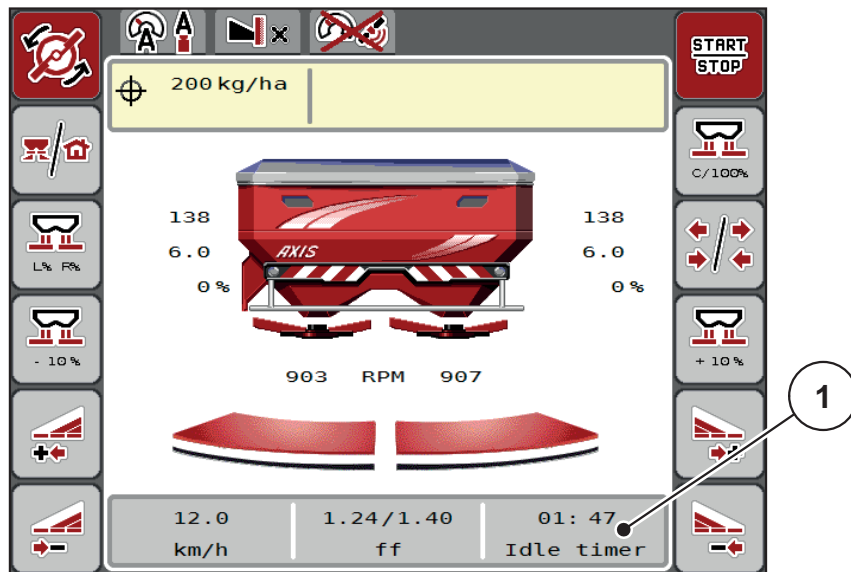

**Figure 5.6:** Display of the idle measurement in the operating screen

[1] Period until the next idle measurement

**NOTICE**

In the case of a reduced speed, **no** idle measurement can be executed if the boundary spreading mode or the section reduction are activated!

**NOTICE**

When the metering slides are closed, an idle measurement is carried out in the background at all times (without alarm message)!

**NOTICE**

Do not reduce the engine speed during the idle measurement in the headland! The tractor and hydraulic circuit must have reached their operating temperature!

**5.5.2 Manual idle measurement**

In the case of unusual changes in the flow factor, start the idle measurement manually.



- In the **main menu**, press the idle measurement key.
  - ▷ The idle measurement is started manually.

## 5.6 Spreading with AUTO km/h operating mode



This operating mode is applied by default for machines without **weighing system**.

### Preconditions for spreading:

- The **AUTO km/h** operating mode must be active (see [4.5.1: AUTO/MAN mode, page 50](#)).
  - The fertiliser settings are defined.
    - Application rate (kg/ha)
    - Working width (m)
    - Spreading disc type
    - Normal speed (RPM)
1. Fill the hopper with fertiliser.

### NOTICE

In order to achieve an optimum spreading result in the **AUTO km/h** operating mode, a calibration is to be carried out before starting the spreading.

2. Conducting calibration for flow factor determination  
or  
manually enter the flow factor from the fertiliser chart.

### ▲ WARNING



#### Risk of injury caused by ejected fertiliser

Ejected fertiliser may cause severe injury.

- ▶ Before activating the spreading discs, ensure that nobody is present in the spreading zone of the mineral fertiliser spreader.



3. Press **Spreading disc start**.
  4. Press **Start/Stop**.
- ▷ **The spreading starts.**

### 5.7 Spreading in the MAN km/h operating mode



If there is no speed signal, the MAN km/h operating mode is active.

1. Open the **Machine settings > AUTO/MAN mode** menu.
2. Select the **MAN km/h** menu entry.
  - ▷ The **Forward speed** input window is displayed.
3. Enter the value for the forward speed during spreading.
4. Press **OK**.
5. Configure the fertiliser settings:
  - Application rate (kg/ha)
  - Working width (m)
6. Fill the hopper with fertiliser.

#### NOTICE

In order to achieve an optimum spreading result in the MAN km/h operating mode, a calibration is to be carried out before starting the spreading.

---

7. Conducting calibration for flow factor determination  
or  
Manually enter the flow factor from the fertiliser chart.



8. Press **Spreading disc start**.
9. Press **Start/Stop**.
  - ▷ **The spreading starts.**

#### NOTICE

Always observe the set speed during spreading.

---



## 5.8 Spreading in the MAN scale operating mode



The **MAN scale** operating mode enables manual adjustment of the metering slide opening during spreading.

The **manual** mode is only applied:

- if there is no speed signal (radar or wheel sensor not available or defective),
- if slug pellets or seeds are spread (fine seeds).

### NOTICE

For a regular spreading of the spreading material, it is imperative to work with a **constant forward speed** in manual operating mode.

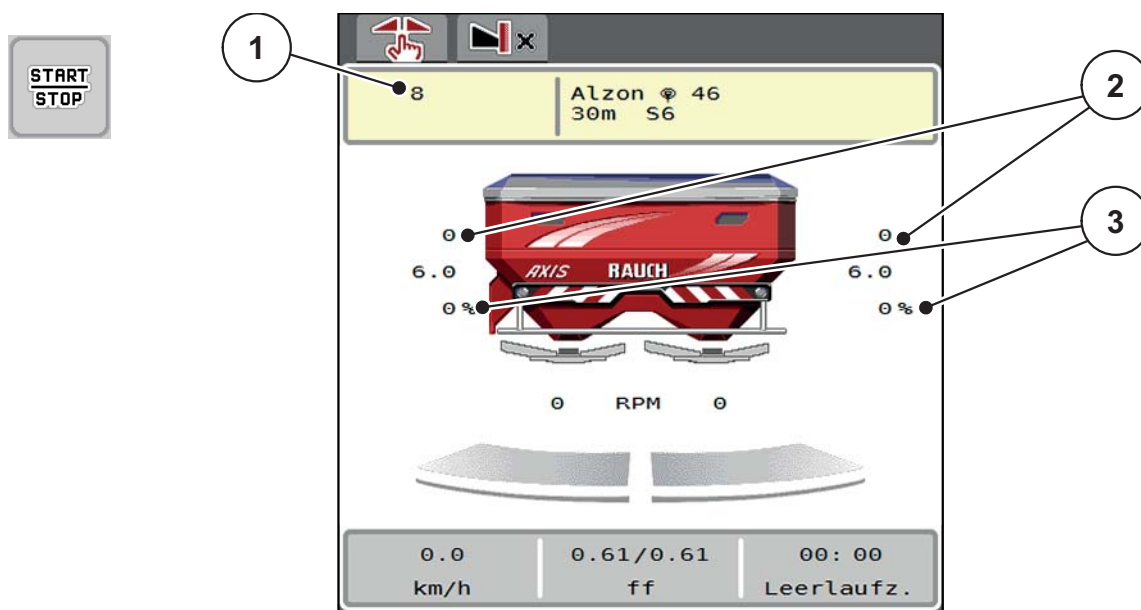

**Figure 5.7:** Man scale operating screen

- [1] Display of metering slide target value scale position
- [2] Display of current metering slide scale position
- [3] Quantity change

1. Open the **Machine settings > AUTO/MAN mode** menu.
2. Select the **MAN scale** menu entry.
  - ▷ The **Slide opening** window is displayed.
3. Enter the scale value for the metering slide opening.
4. Press **OK**.
5. Switch to the operating screen



6. Press **Spreading disc start**.
7. Press **Start/Stop**.
- ▷ **The spreading starts.**

8. To change the metering slide opening, press the **MAN+** or **MAN-** function key.



**L% R%** for selecting the side of the metering slide opening

**MAN+** to increase the metering slide opening or

**MAN-** to reduce the metering slide opening

### NOTICE

In order to achieve an optimum spreading result in manual mode as well, it is recommended to apply the metering slide opening and ground speed values provided in the fertiliser chart.

---

## 5.9 GPS-Control



The AXIS-H ISOBUS machine control unit can be combined with an ISOBUS terminal with SectionControl. Data is exchanged between both devices for automatic switching.

The ISOBUS terminal with SectionControl transfers the specifications on the opening and closing of metering slides to the machine control unit.

The symbol **A** next to the spreading wedges indicates that the automatic function is enabled. The ISOBUS terminal with SectionControl opens and closes the individual sections depending on the respective position in the field. The spreading starts only after pressing **Start/Stop**.

### ▲ WARNING



#### Risk of injury due to ejected fertiliser

The SectionControl function starts the spreading operation automatically, without warning. Escaping fertiliser may lead to injury of the eyes and nasal mucous membrane. There is also a risk of slipping.

- ▶ Ensure that nobody is present in the hazard zone during the spreading operation.

During spreading, **one or both sections** can be closed at any time. If the sections are activated for automatic operation again, the last state requested is restored.

If the ISOBUS terminal with SectionControl is changed from automatic to manual mode, the machine control unit closes the metering slides.

### NOTICE

For the use of the GPS control functions of the AXIS-H ISOBUS machine control unit, the **GPS-Control** setting in the **Machine settings** menu is to be activated!

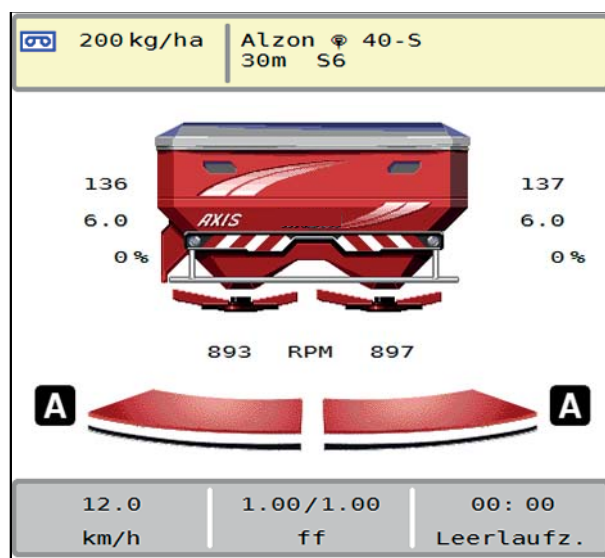
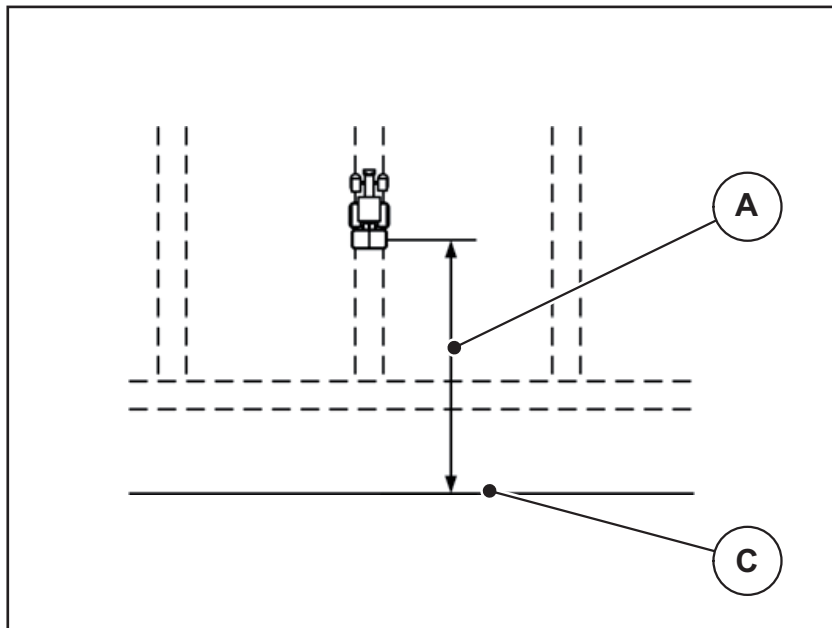

**Figure 5.8:** Spreading operation display in the operating screen with GPS-Control

The **OptiPoint** function by RAUCH calculates the optimal switching-on and switching-off point for spreading in the headland based on the settings in the machine control unit; refer to [4.4.8: Calculate OptiPoint, page 41](#).

### Turn on distance (m)

**Turn on distance** refers to the turn on distance ([figure 5.9 \[A\]](#)) relating to the field border ([figure 5.9 \[C\]](#)). At this position in the field, the metering slides start to open. This distance depends on the type of fertiliser and represents the ideal turn on distance for optimised fertiliser distribution.



**Figure 5.9:** Distance on (relating to field border)

- [A] Switch-on distance
- [C] Field border

If you want to change the switching-on position in the field, you must adjust the **Turn on distance**.

- A lower distance value means that the switch-on position is closer to the field border.
- A greater value means that the turn on position is closer to the centre of the field.

**Turn off distance (m)**

**Turn off distance** refers to the turn off distance (figure 5.10 [A]) relating to the field border (figure 5.10 [C]). At this position in the field, the metering slides start to close.

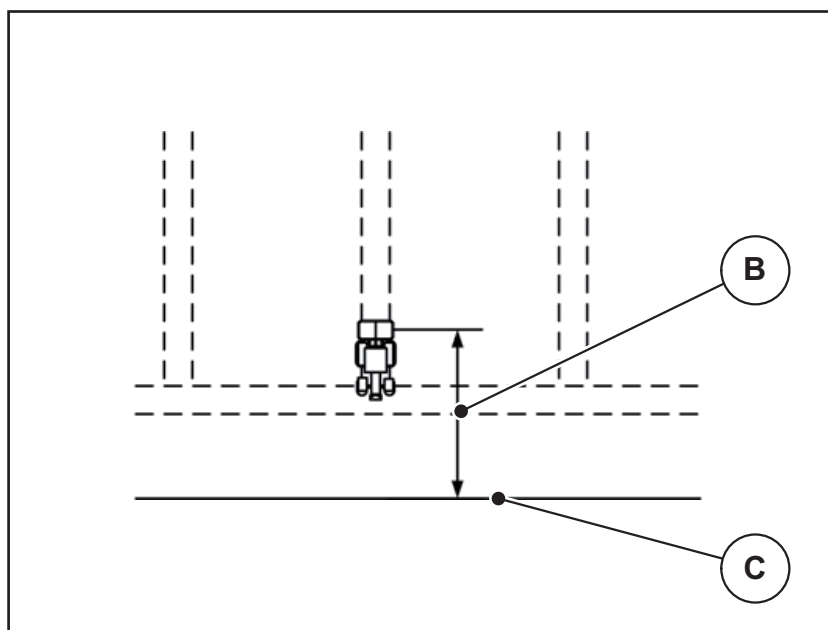

**Figure 5.10:** Distance off (relating to field border)

- [B] Switch-off distance  
[C] Field border

To change the turn off position in the field, the **Turn off distance** value has to be adjusted accordingly.

- A lower value means that the switch-off position is closer to the field border.
- A greater value means that the turn off position is closer to the centre of the field.

If you wish to turn beyond the headland track, enter a greater distance in **Turn off distance**.

Here, the adjustment must be as low as possible so that the metering slides close as soon as the tractor enters the headland track. An adjustment of the switch-off distance may lead to an insufficient fertilisation in the area of the switch-off position in the field.



## 6 Alarm messages and possible causes

Various alarm messages can be displayed on the ISOBUS terminal display.

### 6.1 Meaning of the alarm messages

No.	Message in display	Meaning and possible cause
1	Fault in dosing system. Stop!	The actuator for the metering system cannot reach the set value it is to be moved to. <ul style="list-style-type: none"> <li>● Blockade</li> <li>● No position feedback</li> </ul>
2	Maximum outlet reached! Speed or application rate too high	Metering slide alarm <ul style="list-style-type: none"> <li>● The maximum metering opening is reached.</li> <li>● The set dosing quantity (+/- Quantity) exceeds the maximum metering opening.</li> </ul>
3	Flow factor is outside limits.	The flow factor must lie within a range between <b>0.40 and 1.90</b> <ul style="list-style-type: none"> <li>● The newly calculated or entered flow factor is outside this range.</li> </ul>
4	Hopper left empty.	The level sensor on the left reports "empty". <ul style="list-style-type: none"> <li>● The left-hand hopper is empty.</li> </ul>
5	Hopper right empty.	The level sensor on the right reports "empty". <ul style="list-style-type: none"> <li>● The right-hand hopper is empty.</li> </ul>
15	Memory full. Delete one private fertiliser chart.	A maximum of 30 fertilisers is stored in the memory for the fertiliser charts.
16	Approach drop point Yes = Start	Safety request before drop point is approached automatically. <ul style="list-style-type: none"> <li>● Drop point can be set in the <b>fertiliser settings</b> menu</li> <li>● Fast emptying</li> </ul>
17	Error by setting drop point.	The actuator for the drop point setting cannot reach the set value it is to be moved to. <ul style="list-style-type: none"> <li>● Blockade</li> <li>● No position feedback</li> <li>● Calibration</li> </ul>

No.	Message in display	Meaning and possible cause
18	Drop point blocked	The actuator for the drop point setting cannot reach the set value it is to be moved to. <ul style="list-style-type: none"> <li>● Blockade</li> <li>● No position feedback</li> <li>● Calibration</li> </ul>
19	Defect by setting drop point.	The actuator for the drop point setting cannot reach the set value it is to be moved to. <ul style="list-style-type: none"> <li>● No position feedback</li> </ul>
20	Error on LIN bus participant: [Name].	Communication problem. <ul style="list-style-type: none"> <li>● Defective cable</li> <li>● Loose plug connector</li> </ul>
21	Spreader overloaded!	<b>For weighing spreader only:</b> The mineral fertiliser spreader is overloaded. <ul style="list-style-type: none"> <li>● Too much fertiliser in the hopper</li> </ul>
22	Unknown condition function stop.	Communication problem at Terminal. <ul style="list-style-type: none"> <li>● Possible software error</li> </ul>
26	Activate disc start. Confirm with ENTER	
27	Discs are started up without activation.	Defective or manually switched hydraulic valve.
28	Spreading discs could not start up properly. Deactivate disc start	Spreading discs do not rotate. <ul style="list-style-type: none"> <li>● Blockade</li> <li>● No position feedback</li> </ul>
29	The agitator motor is overloaded	Agitator is blocked. <ul style="list-style-type: none"> <li>● Blockade</li> <li>● Defective connection</li> </ul>
30	The discs shall be activated before opening the metering sliders.	Correct software operation. <ul style="list-style-type: none"> <li>● Start spreading discs</li> <li>● Open metering slide</li> </ul>
31	Idle measurement is necessary for EMC calculation.	Alarm message before the idle measurement. <ul style="list-style-type: none"> <li>● Activate spreading disc start.</li> </ul>



No.	Message in display	Meaning and possible cause
32	Externally controlled parts may move. Risk of injury through squeezing and shearing! Direct ALL persons out of the danger zone. Read the instruction manual. Confirm with ENTER	If the machine control unit is activated, components may move unexpectedly. <ul style="list-style-type: none"> <li>● Follow the displayed instructions only if all risks have been eliminated.</li> </ul>
33	Stop the discs and close the metering sliders.	You may only change into the system/test menu area if the spreading mode has been deactivated. <ul style="list-style-type: none"> <li>● Stop spreading discs</li> <li>● Close metering slide</li> </ul>
34	The spreader is set to reduced disc speed. The idle measurement cannot be started; Confirm this alarm to set the machine back to normal spreading mode.	Idle measurement may only be carried out if neither the border spreading nor the section mode are active.
35	Hydraulic oil too cold; idle measurement must be repeated.	As long as the oil temperature is too low, no idle measurement is possible. The alarm message is cleared once the correct temperature has been reached.
51	Hopper empty.	
52	Error at hopper cover	The position of the hopper cover could not be reached! <ul style="list-style-type: none"> <li>● Blockade</li> <li>● Defective actuator</li> </ul>
53	Defect at hopper cover	The position of the hopper cover could not be reached! <ul style="list-style-type: none"> <li>● Blockade</li> <li>● Defective actuator</li> </ul>
57	Error at hopper cover	The hopper cover actuator cannot reach the target value. <ul style="list-style-type: none"> <li>● Blockage</li> <li>● No position message</li> </ul>
71	Disc speed not reached.	The spreading disc speed is not within the 5 % target range <ul style="list-style-type: none"> <li>● Problem with oil supply</li> <li>● Proportional valve spring is jammed</li> </ul>

### 6.2 Fault/alarm

#### 6.2.1 Acknowledging an alarm message

An alarm message is displayed with a red frame and with a warning symbol.

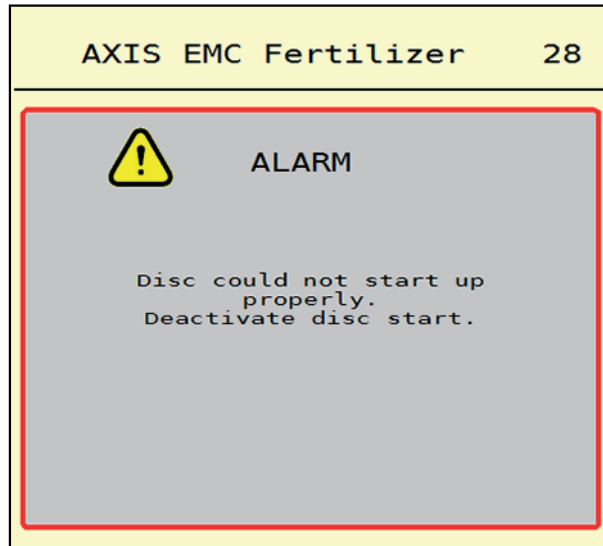

**Figure 6.1:** Alarm message (example)

#### **Acknowledging an alarm message:**

1. Rectify the cause for the alarm message.

Observe the operating manual of the mineral fertiliser spreader and section [6.1: Meaning of the alarm messages, page 89](#).

2. Press the **ACK** (CCI 100) foil button.



#### **NOTICE**

In the case of different ISOBUS terminals, acknowledging the alarm messages may differ.



---

You can use various keys to acknowledge other messages with a yellow frame:

- Enter
- Start/stop

For this purpose, follow the instructions on screen.

## 7 Optional equipment

No.	Illustration	Designation
1	 A black cable with a red connector at one end and a black connector at the other, coiled on a light surface.	Level sensor for AXIS-H EMC
2	 A black cable with a cylindrical metal sensor at one end and a black connector at the other, coiled on a light surface.	Forward speed sensor
3	 A black joystick controller with a white cable and a black connector, shown against a white background.	Joystick



---

## Index

### A

Alarm message  
    acknowledging 90  
    List 87

Application rate 32–33

AXIS fertiliser spreader  
    Metering slide preparation 26

### B

Border spreading mode 74

Boundary spreading mode  
    full border (yield) 40  
    limited (environment) 40

### C

Calibration 32  
    Flow factor calculation 38  
    Forward speed 37

Connection 23–25  
    Example 24–25

Control elements 7–10

### D

Display  
    See operating screen

Display field 11–12

DP  
    Refer to drop point

Drop point 32

### E

Environment-oriented spreading 40

### F

Fast emptying 51

Fertiliser  
    Name 32

Fertiliser chart 32  
    Create 46

Fertiliser settings 31–46

    Application rate 32–33  
    Calibration 32  
    Drop point 32  
    Fertiliser chart 33, 46  
    Fertiliser name 32  
    Flow factor 32  
    GPS-Control 33  
    OptiPoint 33, 41  
    Spreading disc 32  
    TELIMAT 32, 40  
    VariSpread 32–33  
    Working width 32, 35

Flow factor 32  
    Calculation 38

Forward speed 37, 41

Full border spreading 40

Function key 9

Function keys 11

### G

GPS-Control 83  
    Driving strategy 85–86  
    Information 43  
    Turn off distance 33, 86  
    Turn on distance 33, 85

### H

Hopper cover 63

### I

Idle measurement 76  
    manual ~ 78

Information 58  
    GPS-Control 43

### J

Joystick 91  
    Key assignment 67

## Index

---

### **K**

Key  
Menu 29

### **L**

Limited border spreading 40

LIN Bus  
Test 57

### **M**

Machine settings 47–50

Main menu 30  
Fast emptying 51  
Fertiliser settings 31  
Hopper cover 63  
Information 58  
Machine settings 47  
Menu key 29  
System/Test 53  
Weighing trip counter 59

Menu  
Navigation 3, 29  
Overview 22  
Symbols 17

Metering slide 42  
Preparation 26  
Status 14  
Test points 56

### **N**

Nachfüllen 70

Navigation  
Symbols 16

### **O**

Operating mode 11, 49  
AUTO km/h 79  
AUTO km/h + AUTO kg 75  
MAN km/h 80  
Man scale 81

Operating screen 11  
Display field 12  
Symbols 18

Optional equipment 91

OptiPoint 41–86

### **P**

Power supply 23

### **Q**

Quantity  
Remaining quantity 69

### **R**

Remaining quantity 69

### **S**

Scales  
Tare 62

Scroll wheel 9

Sections 14, 37, 71  
Display 15

Softkey 9

Spreading disc  
Type 32

Spreading operation 69–86  
AUTO km/h 79  
AUTO km/h + AUTO kg 75  
Border spreading 74  
Idle measurement 76, 78  
MAN km/h 80  
Man scale 81  
Remaining quantity 69  
Sections 71

Structure 6

Switch-off distance 33

Switch-on distance 33

Symbols

Library 16–21  
Menus 17  
Navigation 16  
Operating screen 18

System/Test 53–57

### **B**

**T**

TELIMAT 32

Quantity 40

Terminal

activation 27

Control elements 7–10

Structure 6

Using the joystick 67

Test/Diagnosis

LIN Bus 57

Metering slide 56

Touch screen 8, 11

Tractor

Requirements 23

**V**

VariSpread 32–33

**W**

Weighing trip counter 59

Weihing spreader

Zero scales 62

Wiegestreuer

nachfüllen 70

Working width 32, 35

**Y**

Yield-oriented spreading 40





## Terms/conditions of warranty

RAUCH units are manufactured with modern production methods and with the greatest care and are subject to numerous inspections.

Therefore RAUCH offers a 12-month warranty subject to the following conditions:

- The warranty begins on the date of purchase.
- The warranty covers material and manufacturing faults. Our liability for third-party products (hydraulic system, electronics) is limited to the warranty of the manufacturer of the equipment. During the warranty period, manufacturing and material faults are corrected free of charge by replacement or repair of the affected parts. Other rights extending beyond the above, such as claims for conversion, reduction or replacement for damages that did not occur in the object of supply are explicitly excluded. Warranty services are provided by authorised workshops, by RAUCH factory representatives or the factory.
- The following are excluded from coverage by the warranty: natural wear, dirt, corrosion and all faults caused by improper handling and external causes. The warranty is rendered void if the owner carries out repairs or modifications to the original state of the supplied product. Warranty claims are rendered void if RAUCH original spare parts were not used. Therefore, the directions in the operating manual must be observed. In all cases of doubt contact our sales representatives or the factory directly. Warranty claims must be submitted to the factory by 30 days at the latest after occurrence of the problem. The date of purchase and the serial number must be indicated. If repairs under the warranty are required, they must be carried out by the authorised workshop only after consultation with RAUCH or the company's appointed representatives. The warranty period is not extended by work carried out under warranty. Shipping faults are not factory faults and therefore are not part of the warranty obligation of the manufacturer.
- No claims for compensation for damages that are not part of RAUCH machines themselves will be accepted. This also means that no liability will be accepted for damage resulting from spreading errors. Unauthorised modifications of RAUCH machines may result in consequential damage, for which the manufacturer will not accept any liability. The manufacturer's liability exclusion will not apply in case of wilful intent or gross negligence by the owner or a senior employee, and in cases where – according to the product liability law – there is liability for personal injury or material damage to privately used objects in the event of defects in the supplied product. It will also not apply in the event that assured properties are absent, if the purpose of the assured properties was to protect the purchaser against damage that does not involve the supplied product itself.



**RAUCH**  
POWER FOR PRECISION

## RAUCH Landmaschinenfabrik GmbH



Landstraße 14 · D-76547 Sinzheim



Victoria-Boulevard E200 · D-77836 Rheinmünster

Phone +49 (0) 7221/985-0 · Fax +49 (0) 7221/985-200  
info@rauch.de · www.rauch.de · wap.rauch.de

