

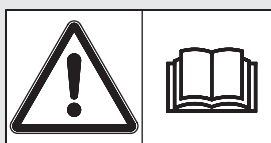

RAUCH

POWER FOR PRECISION

OPERATOR MANUAL



**Please read carefully
before using the machine!**

Store carefully for future
use!

This Operator Manual should be considered as part of the machine. Suppliers of new and second-hand machines are obliged to indicate in writing that the Operator Manual has been delivered with the machine.

QUANTRON-E

Translation of the original
operating manual

5900660-e-en-0909

Preface

Dear customer

Your purchase of the control unit Quantron E for the AXIS fertiliser spreader indicates your confidence in our products. Thank you! We want to justify your trust. You have purchased a powerful and reliable control unit. However, if any problems occur: Our Customer Service is always ready to help.

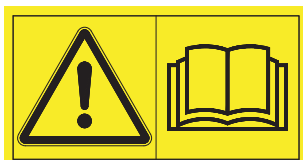

Please read this operator's manual and the operator's manual for the fertiliser spreader carefully before operating the control unit and follow all instructions.

This manual may also contain descriptions of equipment and options that are not included with the feature package of your control unit.

You should be aware that damage caused by incorrect operation or improper use may not be covered by warranty claims.

CAUTION



Note the serial number of the control unit and machine number!

The control unit Quantron E is calibrated at the factory for the fertiliser spreader with which it was delivered. It cannot be connected to another fertiliser spreader without requiring recalibration.

Please record the serial number of the control unit and the machine number of the fertiliser spreader. These numbers must be checked when connecting the control unit to the fertiliser spreader.

Serial number control unit

Machine number of fertiliser spreader

Year of manufacture:

Technical improvements

We are continuously improving our products. For this reason we reserve the right to make any improvements and changes to our machine that we consider necessary without notice. We do not accept any obligation to make such improvements or changes on machines that have already been sold.

We will be pleased to answer any other questions that you might have.

Yours sincerely

RAUCH

Landmaschinenfabrik GmbH

Preface

Technical improvements

1	User instructions	3
1.1	About this operator manual	3
1.2	Information on layout	3
1.2.1	Meaning of safety precautions	3
1.2.2	Instructions and procedures	5
1.2.3	Lists	5
2	Layout and function	7
2.1	Overview of the AXIS versions supported	7
2.2	Layout of the control unit - Overview	8
2.3	Controls, keys	9
2.4	Display	10
2.5	Structural overview of menu	12
3	Attachment and installation	13
3.1	Requirements for the tractor	13
3.2	Connections, sockets	13
3.2.1	Power supply	13
3.2.2	7-pin plug connector	14
3.3	Connecting the control unit	14
3.4	Preparation of metering slide	19
4	Operation Quantron E	21
4.1	Switching on the control unit	21
4.2	Weighing - Tripcounter	23
4.2.1	Trip counter	24
4.2.2	Remaining fertiliser volume	25
4.2.3	Weigh quantity	27
4.2.4	Machine tare	30
4.3	Main menu	31
4.4	Fertiliser settings	32
4.4.1	Application rate	34
4.4.2	Working width	35
4.4.3	Flow factor	36
4.4.4	Calibration test	38
4.4.5	Drop point (L+R)	43
4.4.6	Fertiliser chart	44
4.5	Hopper configuration	46
4.5.1	Speed calibration	47
4.5.2	AUTO / MAN mode	50
4.5.3	+/- appl. rate	59
4.5.4	Curve correction	59
4.6	Fast emptying	60

Table of Contents

4.7	Field data	.62
4.7.1	Select field file.	.62
4.7.2	Creating a new field file	.63
4.7.3	Starting recording	.63
4.7.4	Stopping recording	.65
4.7.5	Importing and exporting operating data	.65
4.8	System / Test	.66
4.8.1	Setting language.	.67
4.8.2	Display config.	.68
4.8.3	Test / Diagnosis	.69
4.8.4	Data transmission.	.71
4.8.5	Service	.74
4.9	Special functions	.75
4.9.1	Text input	.75
4.9.2	Input of values using the cursor keys	.76
5	Alarm messages and possible causes	77
5.1	Meaning of alarm messages	.77
5.2	Clear fault / alarm.	.79
5.2.1	Acknowledging alarm message:	.79
5.2.2	Resolving problems with the flow factor regulation (only AXIS W):	.79
6	Special equipment/options	81
7	Guarantee and warranty	83

1 User instructions

1.1 About this operator manual

This operator manual is a **component** of the control unit **Quantron E**.

The operator manual contains important instructions for the **safe, correct** and economical **operation** and **maintenance** of the control unit. Your attention will help **to prevent dangers, reduce** repair costs and downtime and will increase the reliability and service life of the machine.

The operator manual is a component of the machine. All documentation must be kept within reach at the place of operation of the control unit (e. g. in the tractor).

The operator manual is not intended to replace your own **personal responsibility** as the owner and operator of the control units Quantron E.

Brief instructions are supplied with the control unit Quantron E. If these are not included in the scope of supply please contact us.

1.2 Information on layout

1.2.1 Meaning of safety precautions

In the operator manual, the safety precautions are classified according to how serious the danger is and the probability of its occurrence.

The warning symbols draw attention to the unavoidable residual risks inherent in the design to which users of the control unit are exposed. The safety instructions used are structured as follows:

Signal word	
Symbol	Explanation
Example	
▲ DANGER	
	<p>Description of sources of danger</p> <p>Description of the danger and possible consequences.</p> <p>Ignoring this warning will result in very serious injury or death.</p> <p>► Measures to prevent this danger.</p>

Danger levels in the safety precautions

The danger level is identified by the signal word. The danger levels are classified as follows:

DANGER



Type and source of the danger

This note warns of a danger posing an immediate threat to the health and life of people.

Ignoring this warning will result in very serious injury or death.

- ▶ Always observe the measures described to prevent this danger.
-

WARNING



Type of danger

This note warns of a potentially dangerous situation for personal health.

Ignoring this warning will result in serious injury.

- ▶ Always observe the measures described to prevent this danger.
-

CAUTION



Type of danger

This note warns of a potentially dangerous situation for personal health or of material and environmental damage.

Failure to observe this warning will result in damage to the product or the surroundings.

- ▶ Always observe the measures described to prevent this danger.
-

NOTICE

General instructions include tips for usage and useful information but not warnings of dangers.

1.2.2 Instructions and procedures

Steps that the operator must carry out are shown as a numbered list.

1. Instruction for action step 1
2. Instruction for action step 2

Instructions that only have one step are not numbered. The same applies for action steps that do not have a specific sequence.

A bullet is placed in front on these instructions:

- Handling instructions.

1.2.3 Lists

Lists without a specific sequence are shown as lists with bullet points (level 1) and dashes (level 2):

- Property A
 - Point A
 - Point B
- Property B

2 Layout and function

2.1 Overview of the AXIS versions supported

Function/Options	AXIS Q	AXIS W
Ground speed dependent spreading	<ul style="list-style-type: none">● AXIS 20.1 Q● AXIS 30.1 Q● AXIS 40.1 Q	
Weighing spreader		<ul style="list-style-type: none">● AXIS 30.1 W● AXIS 40.1 W● AXIS 50.1 W
Electrical adjustment of drop point		<ul style="list-style-type: none">● AXIS 50.1 W

2.2 Layout of the control unit - Overview

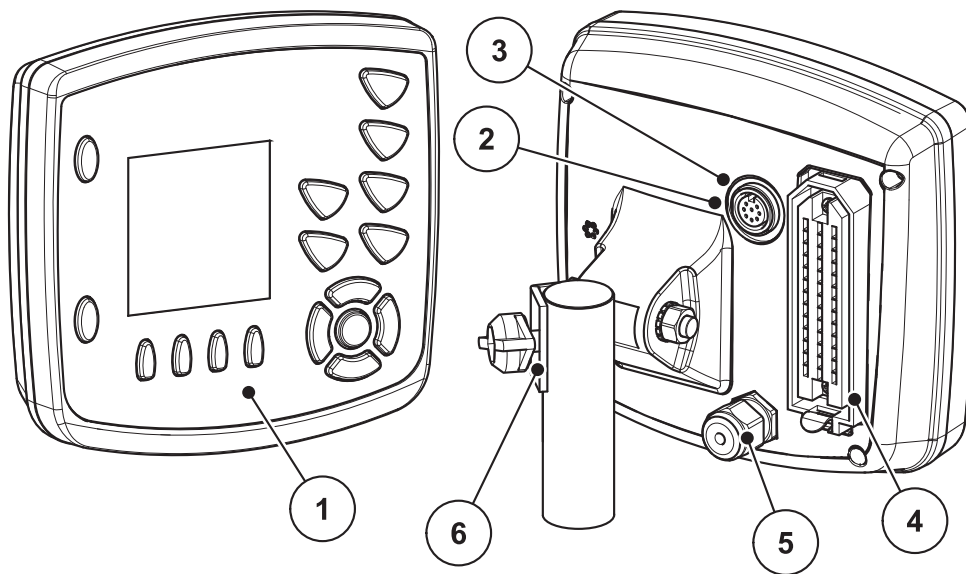

Figure 2.1: Control unit Quantron E

No.	Designation	Function
1	Control panel	Keys for operation of the unit and the display for operating screens.
2	V24 data port	Serial interface (RS232) with LH 5000 and ASD protocol, designed for connection of an RS232 Y- cable for connecting to a remote terminal.
3	8-pin plug connector	Plug connection (DIN 9684-1/ISO 11786) for connecting the 7-way to 8-way cable for the speed sensor.
4	Machine cable plug connector	39-pin plug connector for connecting the machine cable to the positioning cylinder.
5	Power supply	3-pin plug connector conforming to DIN 9680 / ISO 12369 for connecting the power supply.
6	Bracket	Attachment for securing the control unit to the tractor.

2.3 Controls, keys

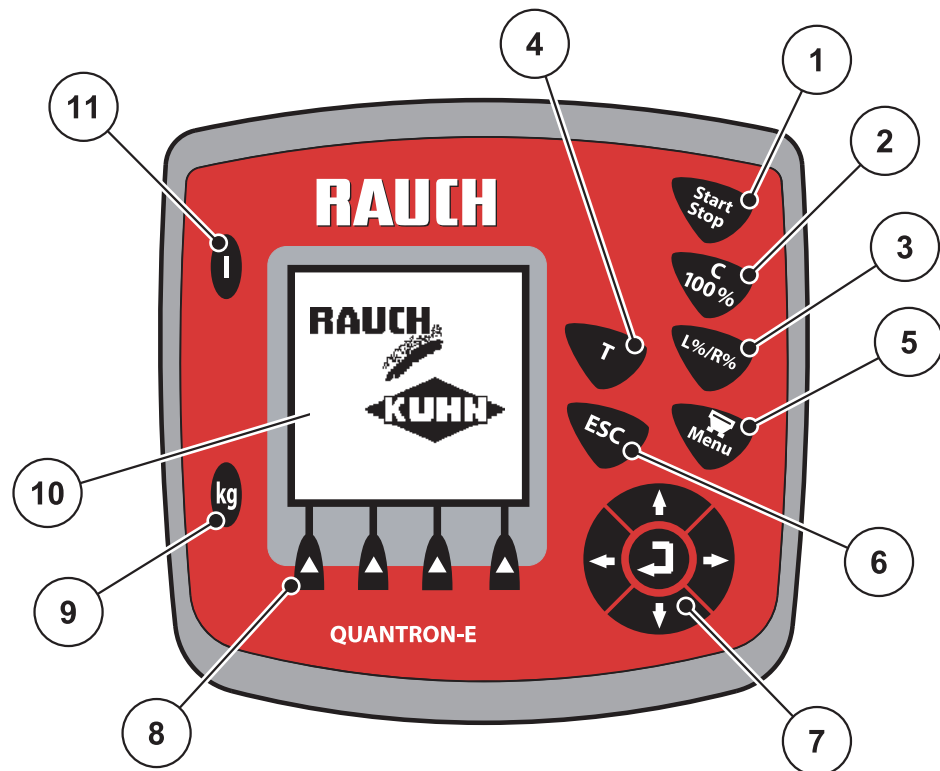

Figure 2.2: Control panel on front of unit

NOTICE

The operator's manual describes the functions of the control unit Quantron E as of software version 3.30.00.

No.	Designation	Function
1	Start / Stop	Starts and stops spreading.
2	Clear / Reset	<ul style="list-style-type: none"> • Clear an input in an input field, • reset the excess quantity to 100 %, • Acknowledge alarm messages.
3	Preselect partial width setting	Preselect partial widths for changing the application rates (Left or Right or Left + Right).
4	T-key (Telimat)	Button to display the Telimat setting
5	Menu	Switch between operating screen and main menu.
6	ESC	For aborting information input and / or returning to the previous menu at the same time.

No.	Designation	Function
7	Navigation field	<p>4 arrow keys and one Enter key for navigation in the menus and the input fields.</p> <ul style="list-style-type: none"> ● Arrow keys for moving the cursor on the display or to highlight an input field. ● Enter key to confirm an input.
8	Function keys F1 to F4	Selection of the functions displayed by the function button.
9	Weighing - Trip-counter	<ul style="list-style-type: none"> ● Display of the remaining fertiliser volume that is still in the hopper. ● Tripcounter ● kg rest ● Metre counter ● Weigh volume ¹ ● Tare scales ¹
10	Display	display of operating screens
11	On / Off	Switching the unit on/off

1. The menu item only appears on the display if the fertiliser spreader used is an AXIS W.

2.4 Display

The display shows the current status information and the selection and input options for the control unit.

The most important information on the operation of the fertiliser spreader is displayed in the **operating screen**.

Description of the operating screen

NOTICE

The exact representation of the operating screen depends on the actual settings selected, see section [4.8.2: Display config., page 68](#).

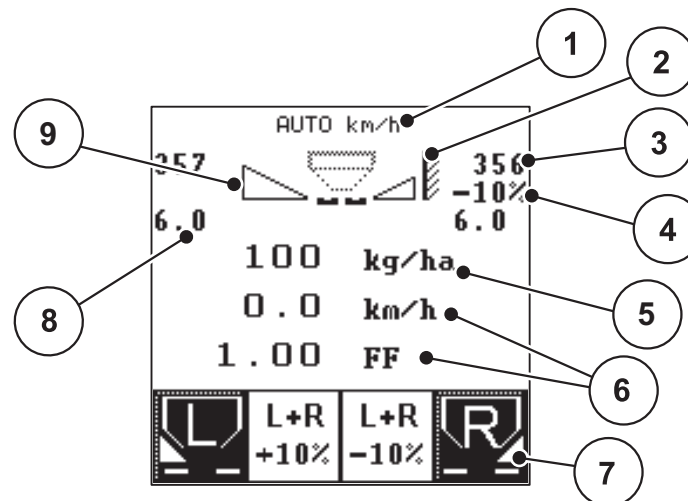
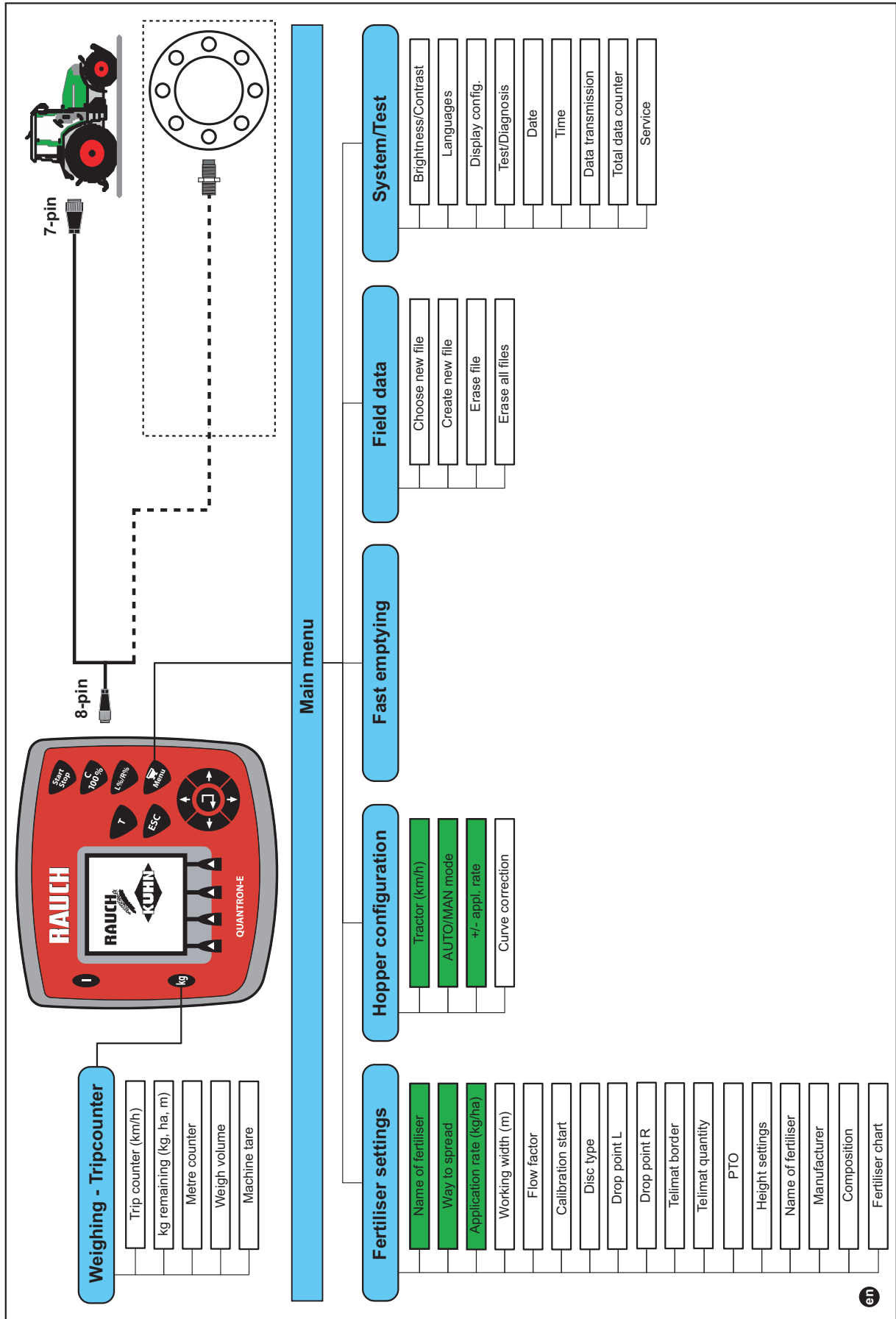

Figure 2.3: Display on the control unit (using the operating screen as an example)

The icons and displays in the example have the following meaning:

No.	Icon / Display	Meaning (in the example)
1	Operating mode	Shows the current operating mode. <ul style="list-style-type: none"> • Auto km/h uses the radar signal or wheel signal for determining the speed.
2	Telimat icon	This symbol appears if the Telimat Sensors are fitted and the Telimat function is activated (factory setting) or the T button has been activated.
3	Metering slide scale opening right	Current opening position of the right hand metering slide.
4	Weight change right	Weight change (+/-) in percent. <ul style="list-style-type: none"> • Display of quantity changes. • Range of values +/- 1..99 % possible.
5	Application rate	Preset application rate.
6	Display fields	Configurable display fields (here: ground speed, flow factor). <ul style="list-style-type: none"> • Possible configuration: see section 4.8.2: Display config., page 68.
7	Icon fields	Icons assigned to fields depending on the menu . <ul style="list-style-type: none"> • Selection of the function by means of the Function buttons located underneath.
8	Drop point	Only AXIS 50.1 W: Display of the drop point position
9	Partial width right	Display of status of partial width right. <ul style="list-style-type: none"> • No icon: partial width right not selected. • Empty icon (contour): Partial width right selected but not active. • Icon with black background: Partial width in spreader operation.

2.5 Structural overview of menu



3 Attachment and installation

3.1 Requirements for the tractor

Before installing the control unit, check to make sure your tractor meets the following requirements:

- Minimum voltage **11 V** is essential **at all times**, even if multiple consumers are connected simultaneously (e.g. air conditioner, lights).
- The PTO speed can be set to **540 rpm** and must be maintained (basic requirement for correct working width).

NOTICE

On tractors without load-switchable gears, the ground speed must be selected by using the correct gear ratio in such a way that it corresponds to a PTO speed of 540 r.p.m.

- A 7-pin socket (DIN 9684-1/ISO 11786). The control unit receives the impulse for the current ground speed through this socket.

NOTICE

The 7-pin socket for the tractor and the ground speed sensor can be obtained as an expansion kit (Option), see [Figure 3.3](#) to [Figure 3.5](#).

3.2 Connections, sockets

3.2.1 Power supply

The control unit is supplied with power from the tractor via the 3-pin power supply socket (DIN 9680/ISO 12369).

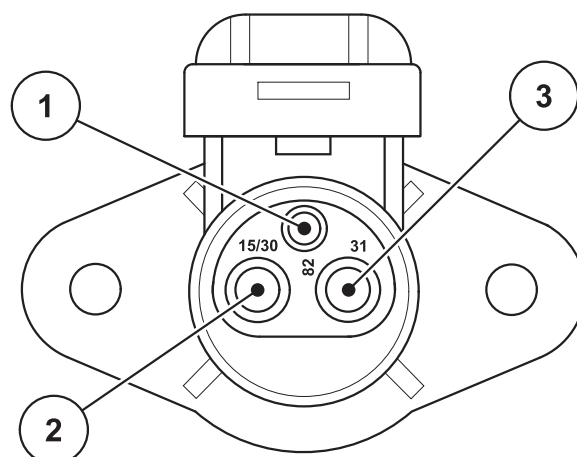

- [1] PIN 1: is not required
- [2] PIN 2: (15/30): +12 V
- [3] PIN 3: (31): earth

Figure 3.1: PIN assignment of power socket

3.2.2 7-pin plug connector

The control unit receives the impulses for the current traverse speed via the 7-pin socket (DIN 9684-1/ISO 11786). To do so, the 7-pin to 8-pin cable (accessory) is connected to the ground speed sensor at the plug connector.

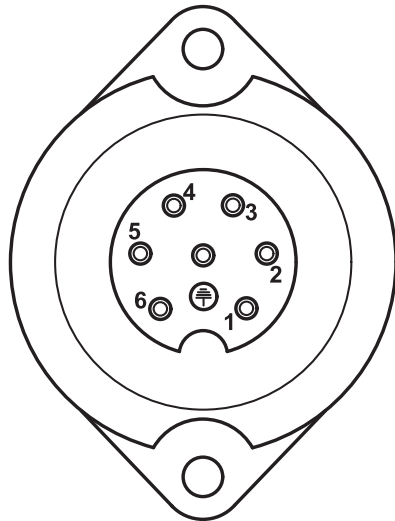

- [1] PIN 1: Actual ground speed (radar)
- [2] PIN 2: Theoretical ground speed (e. g. gearbox, wheel sensor)

Figure 3.2: PIN assignment for 7-pin plug connector

3.3 Connecting the control unit

▲ CAUTION



Note machine number

The control unit Quantron E is calibrated at the factory for the fertiliser spreader with which it was delivered.

- ▶ Connect the control unit control unit to the correct fertiliser spreader only.

Depending on the equipment, there are different methods of attaching the control unit to the fertiliser spreader. For schematic terminal diagrams see below:

- for the standard connection on [page 16](#),
- for the connection with wheel sensor on [page 17](#),
- for the connection with wheel sensor and machine cable on [page 18](#).

Carry out the installation in the following order.

- Select a suitable position in the tractor cabin (in the **driver's field of view**) to attach the control unit.
- Install the control unit with the **bracket** in the tractor cabin.
- Connect the control unit to the 7-pin socket or to the ground speed sensor (depending on the equipment package, see [Figure 3.3](#) to [Figure 3.5](#)).
- Connect the control unit to the actuating cylinders of the fertiliser spreader using the 39-pin machine cable.
- Connect the control unit to the tractor power supply using the 3-pin plug connector.

Standard schematic terminal diagram:

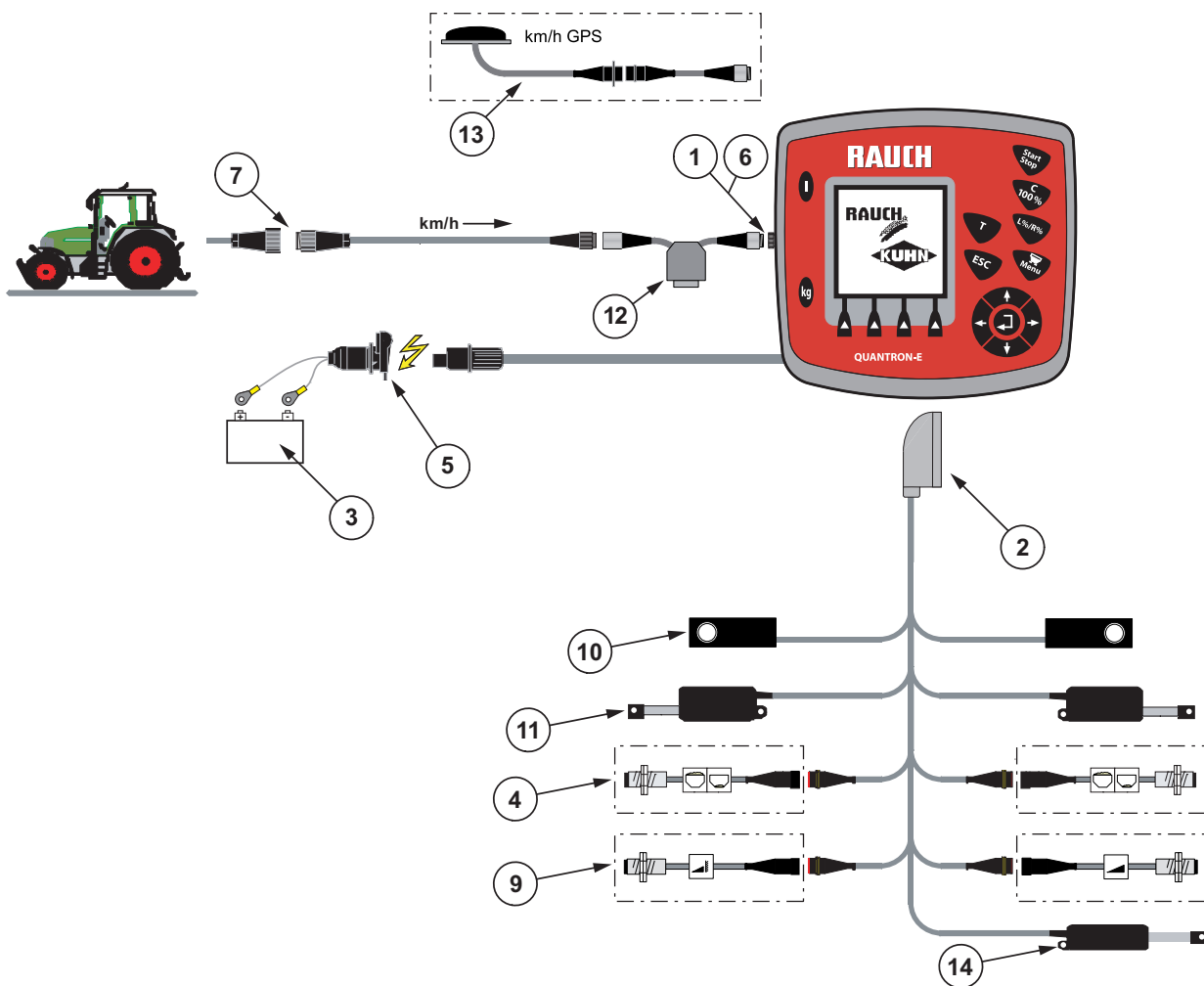

Figure 3.3: Schematic terminal diagram Quantron E (machine cable)

- [1] RS232 serial interface
- [2] 39-pin machine connector
- [3] Battery
- [4] Option (level sensor left/right)
- [5] 3-pin plug connector as per DIN 9680 / ISO 12369
- [6] 8-pin plug connector
- [7] 7-pin plug connector conforming to DIN 9684
- [9] Option (Telimat sensor top/bottom)
- [10] Weigh cell left/right (only on AXIS 30.1 W - 40.1 W - 50.1 W)
- [11] Metering slide actuator left/right
- [12] Option Y cable (V24 RS232 interface for storage medium)
- [13] Option (GPS cable and receiver)
- [14] Option drop point adjustment (only for AXIS 50.1 W)

Wheel sensor schematic terminal diagram:

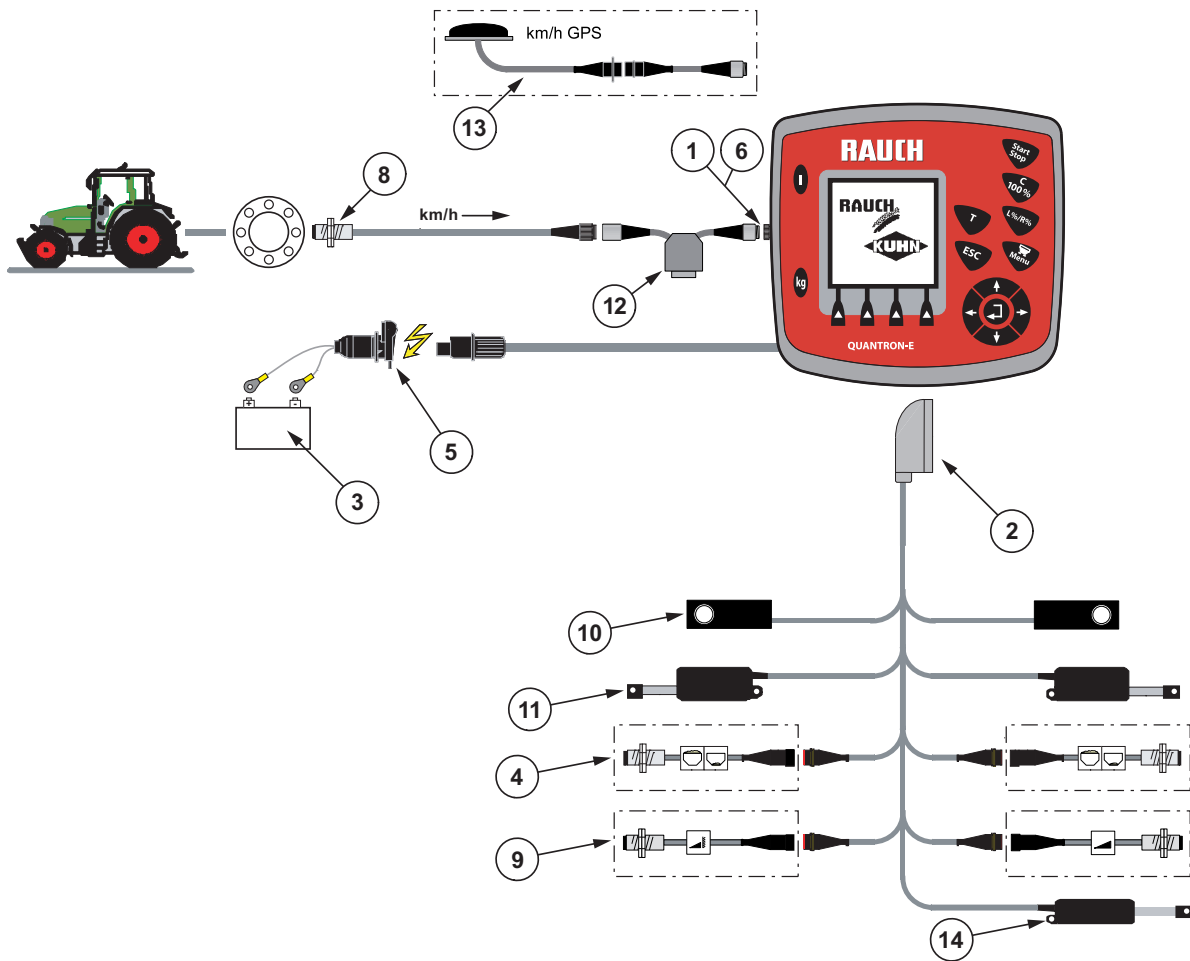

Figure 3.4: Schematic terminal diagram Quantron E (machine cable)

- [1] RS232 serial interface
- [2] 39-pin machine connector
- [3] Battery
- [4] Option (level sensor left/right)
- [5] 3-pin plug connector as per DIN 9680 / ISO 12369
- [6] 8-pin plug connector
- [8] Ground speed sensor
- [9] Option (Telimat sensor top/bottom)
- [10] Weigh cell left/right (only on AXIS 30.1 W - 40.1 W - 50.1 W)
- [11] Metering slide actuator left/right
- [12] Option Y cable (V24 RS232 interface for storage medium)
- [13] Option (GPS cable and receiver)
- [14] Option drop point adjustment (only for AXIS 50.1 W)

Machine cable schematic terminal diagram:

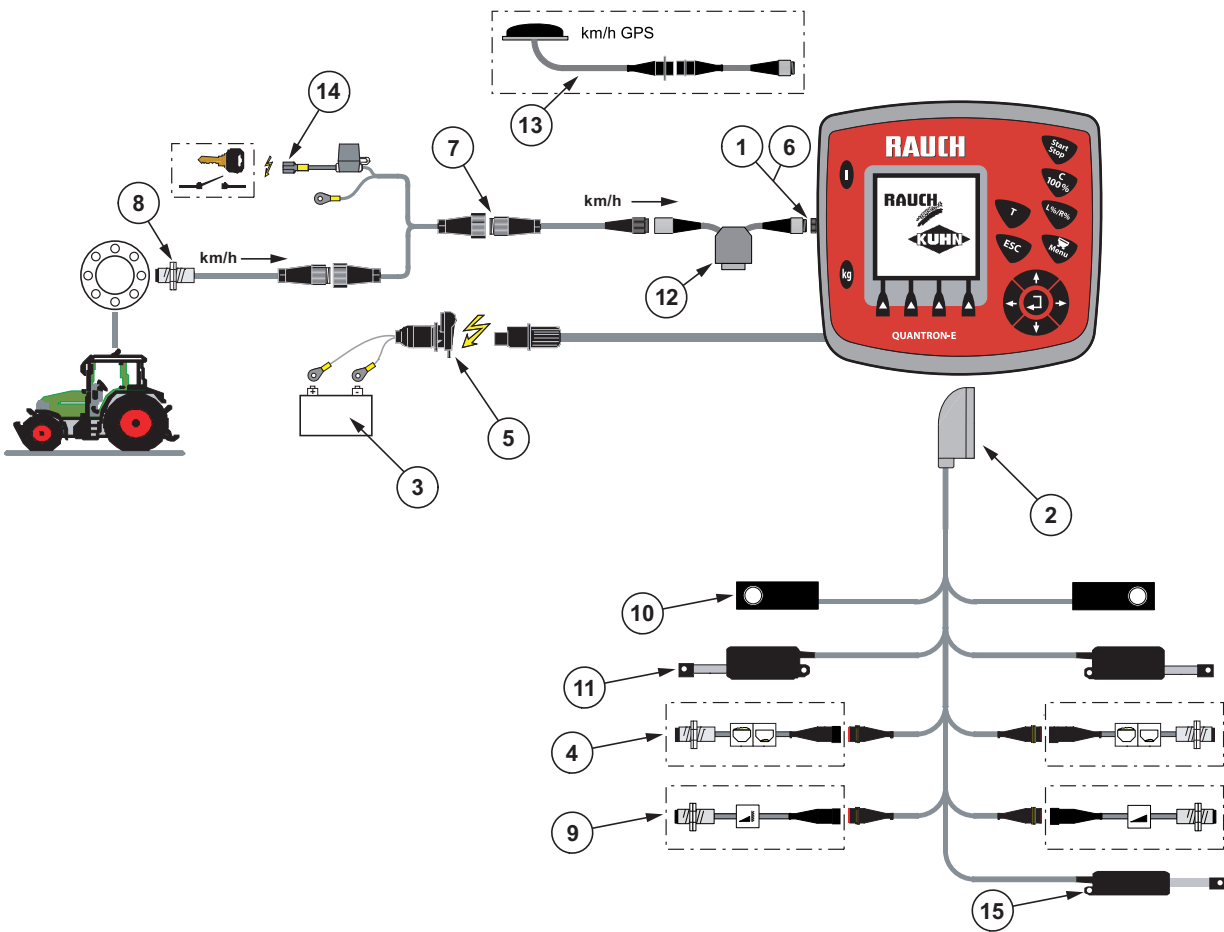

Figure 3.5: Schematic terminal diagram Quantron E (machine cable)

- [1] RS232 serial interface
- [2] 39-pin machine connector
- [3] Battery
- [4] Option (level sensor left/right)
- [5] 3-pin plug connector as per DIN 9680 / ISO 12369
- [6] 8-pin plug connector
- [7] 7-pin plug connector conforming to DIN 9684
- [8] Ground speed sensor
- [9] Option (Telimat sensor top/bottom)
- [10] Weighing cell left/right (only on AXIS 30.1 W - 40.1 W - 50.1 W)
- [11] Dispenser actuator left/right
- [12] Option Y-cable (V24 RS232 interface for storage medium)
- [13] Option (GPS cable and receiver)
- [14] Option (Quantron E power supply via ignition lock)
- [15] Drop point adjustment option (only for AXIS 50.1 W)

3.4 Preparation of metering slide

The AXIS 20.1 Q, AXIS 30.1 W, AXIS 30.1 Q, AXIS 40.1 W, AXIS 40.1 Q and AXIS 50.1 W fertiliser spreader have an electronic slide control for adjusting the spreading volume.

⚠ CAUTION



Observe the position of the metering slide

The operation of the actuators by the Quantron E can damage the metering slide if the stop levers are incorrectly positioned.

- ▶ Always clamp the stop lever at the maximum scale position.

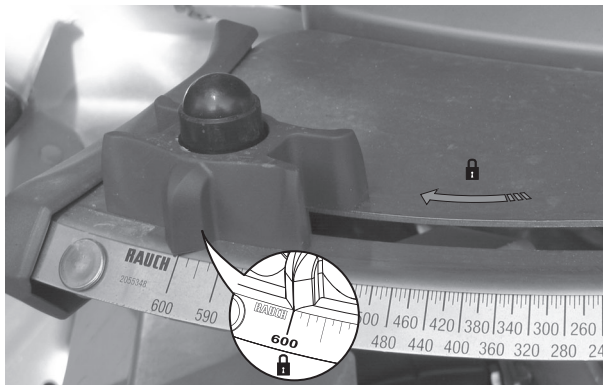

Figure 3.6: Preparation of the metering slide (example)

NOTICE

Observe the operating manual for the fertiliser spreader.

4 Operation Quantron E

4.1 Switching on the control unit

Requirements:

- The control unit is correctly connected to the fertiliser spreader and the tractor ([3.3: Connecting the control unit, page 14](#)).
- The voltage is at least **11 V**.

NOTICE

The operator manual describes the functions of the control unit Quantron E **as of software version 3.30.00**.

⚠ CAUTION



Risk of injury from discharged fertiliser

Only for mineral fertiliser broadcasters equipped with electronic control units

In the event of faults, the metering slide could open unexpectedly en route to the spreading location. There is a danger of people slipping on the discharged fertiliser and injuring themselves.

- ▶ **Before setting off to the spreading location** you must switch off the Quantron E electronic control unit.

Switch on:

- Press the **ON/OFF** switch.
 - ▷ After a few seconds, the start interface appears on the control unit.
 - ▷ Then the **boot menu** is displayed for a few seconds.
 - ▷ Then the **operating screen** appears.

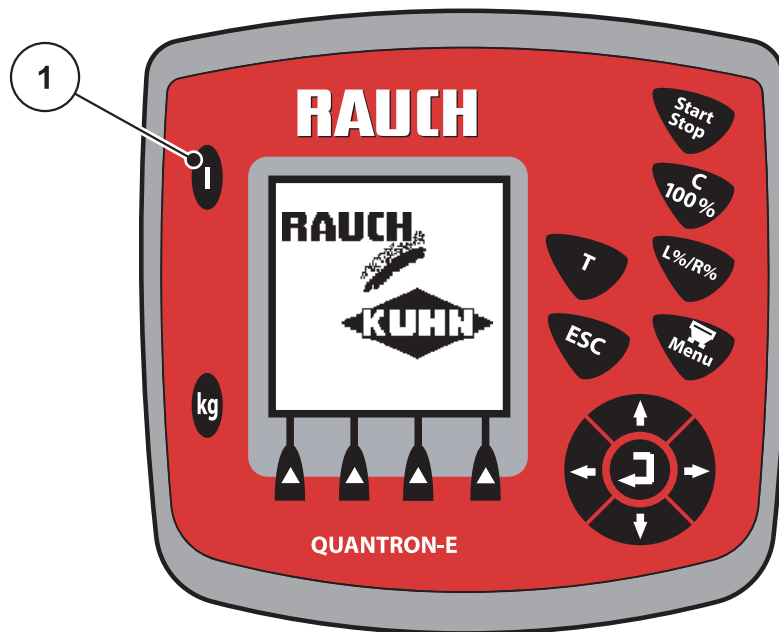

Figure 4.1: Start Quantron E

[1] ON/OFF switch

4.2 Weighing - Tripcounter

In this menu you can have the values of the spreading work carried out displayed and you can perform functions for the weighing operation.

- Press the **kg** key on the control unit.
 - ▷ The **Weighing-Tripcounter** menu opens.

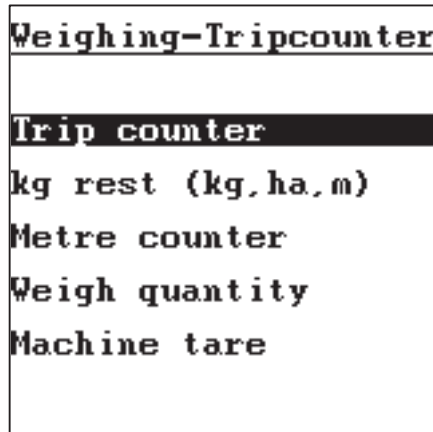

Figure 4.2: Weighing-Tripcounter menu

Submenu	Meaning	Description
Trip counter	Display of the spread volume, area spread and spread distance.	page 24
kg rest (kg, ha, m)	Display of the remaining spread volume, area and distance.	page 25
Metre counter	Display of the distance travelled since the last reset of the metre counter.	Resetting (zeroing) by the button C/100 %
Weigh quantity ¹	The window weigh quantity appears in the display.	page 27
Machine tare ¹	Weighing value for empty scales is set to "0 kg".	page 30

1. The menu item only appears on the display if the fertiliser spreader used is an AXIS W.

How to select a submenu:

1. Highlight the submenu with the black bar in the display. The highlight bar can be moved up and down with the **arrow keys**.
2. Open the highlighted submenu with the **Enter key**.

4.2.1 Trip counter

You can find values for the completed spreading work (time, area, distance) with this menu.

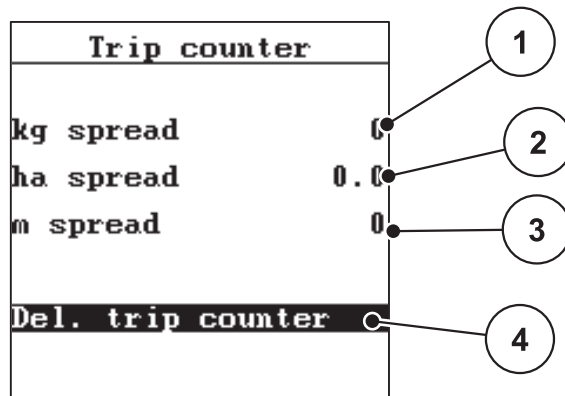

Figure 4.3: Trip counter menu

- [1] Display of spread amount since the last reset
- [2] Display of spread area since the last reset
- [3] Display of spread distance since the last reset
- [4] Clearing trip counter: all values to 0

Display and clear trip counter:

1. Switch from the **Weighing-Tripcounter** menu to the **Trip counter** menu.
 - ▷ The values determined for the spread volume, the spread area and the spread distance **since the last deletion** appear in the display.
2. To clear the trip counter: The **Del. trip counter** field is highlighted in the display. Confirm with the **Enter button**.
 - ▷ All values of the trip counter are reset to 0.
3. Press the **kg key** once.
 - ▷ This returns you to the operating screen.

Checking the trip counter during spreading:

You can switch to the **Trip counter** menu and read the current values during spreading, i.e. with open slides.

NOTICE

If you should wish to constantly observe the values during the spreading procedure you can also assign the freely selectable display fields on the operating screen with **kg Trip**, **ha Trip** or **m Trip**, see section [4.8.2: Display config...](#) [page 68](#).

4.2.2 Remaining fertiliser volume

In the **kg rest** menu, you can call up the **remaining fertiliser volume** in the hopper.

The menu shows the possible **area (ha)** and **distance (m)** that can be spread with the remaining fertiliser volume. Both displays are calculated based on the following values:

- Fertiliser settings
 - Application rate
 - Working width

NOTICE

The current load weight can only be determined in the weighing spreader by weighing. In all other spreaders the remaining fertiliser volume is calculated from the fertiliser and machine settings and from the travelling signal and the input of the filling volume must be made manually.

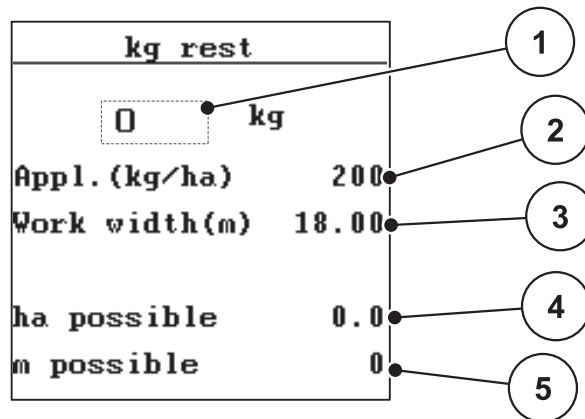

Figure 4.4: kg rest menu

- [1] Remaining fertiliser input field (in the case of the weighing spreader only the display field of the actual remaining fertiliser volume)
- [2] Application rate (display field from fertiliser settings)
- [3] Working width (display field from fertiliser settings)
- [4] Display of area that potentially can be spread with the remaining weight of fertiliser
- [5] Display of possible distance that can be spread with the remaining weight of fertiliser

Entering the remaining fertiliser volume when refilling (not with weighing spreader):

1. Switch from the **Weighing-Tripcounter** menu to the **kg rest** menu.
 - ▷ The remaining fertiliser volume from the last spreading process appears in the display.
2. Fill the hopper.
3. Input the new total weight of fertiliser in the hopper. Confirm the input by pressing the **Enter key**.

See also [4.9.2: Input of values using the cursor keys, page 76](#).

 - ▷ The device calculates the values for the possible spread area and the possible spread distance.

NOTICE

The values for application rate and working width cannot be changed in this menu. They are for information only.

4. Press the **kg key** once.
 - ▷ **This returns you to the operating screen.**

Calling up the remaining fertiliser volume during spreading:

During the spreading work, the remaining fertiliser volume is continuously recalculated and displayed.

You can switch to the **kg rest** menu during spreading, i.e. with open slides, and read the remaining weight in the hopper.

NOTICE

If you should wish to constantly observe the values during the spreading procedure you can also assign the freely selectable display fields on the operating screen with **kg rest**, **ha rest** or **m rest**, see section [4.8.2: Display config., page 68](#).

4.2.3 Weigh quantity

In this menu you can weigh the fertiliser volume contained in the hopper and set the parameters for controlling the flow factor.

NOTICE

The **Weigh Quantity** function can only be requested if the fertiliser spreader being used is an **AXIS W**.

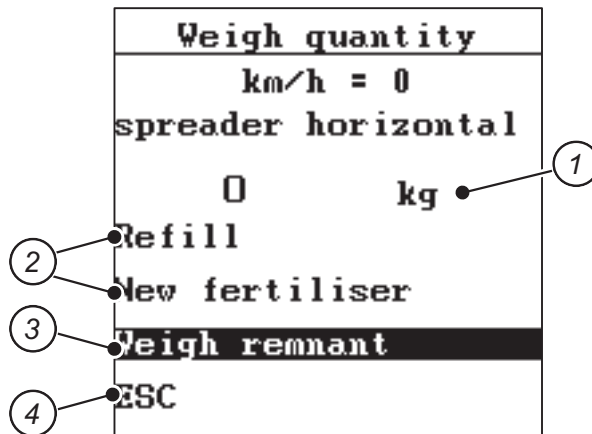

Figure 4.5: Weigh quantity menu

- [1] Weighed volume in the hopper
- [2] Filling options
- [3] Weigh remnant (only displayed for the operating mode **Auto km/h + Stat. kg**)
- [4] Quit

NOTICE

The function **Volume quantity** can only be confirmed when the machine is at a standstill.

The menu shows the **remaining fertiliser volume** in the hopper. This volume depends on the following values:

- Menu item **Weigh quantity**
- Menu item **Machine tare**

NOTICE

The **Weigh quantity** function is only effective if the system is using either the **Auto km/h + Auto kg** or **Auto km/h + Stat. kg** operating modes.

For the control unit delivered with the **AXIS W** fertiliser spreader, the **Auto km/h + Auto kg** operating mode is preselected as standard at the factory.

When weighing the volume ensure that:

- the fertiliser spreader is at a standstill,
- the PTO shaft is switched off,
- the fertiliser spreader is horizontal and off the ground.
- the tractor is at a standstill
- the Quantron E is switched on.

Weighing the fertiliser volume in the hopper:

1. Fill the hopper.
 - ▷ A window appears in the display which shows the remaining fertiliser volume.
2. Highlight the type of filling carried out on the display:
 - Refill:** Continue spreading with the same fertiliser
 - New fertiliser:** Flow factor set to 1.0 and a new flow factor regulation will follow.
 - ESC** Quit
3. Confirm with the **Enter** button.
 - ▷ **The operating screen appears on the display. The weighed quantity can be superimposed on the display field.**

NOTICE

In order to display the **remaining fertiliser quantity** on the **operating screen**, the display option **kg left** must be selected ([4.8.2: Display config., page 68](#)).

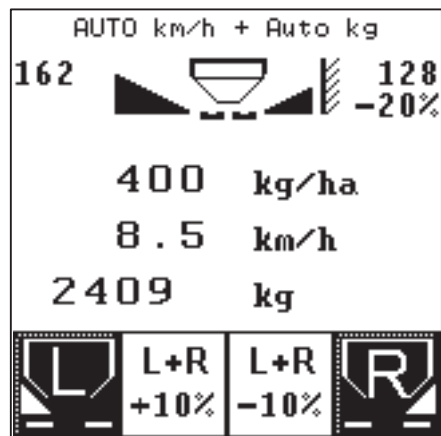

Figure 4.6: Operating screen with weighed quantity

Working with the weighed fertiliser quantity, topping up the hopper:

1. Tare the scales.
See [4.2.4: Machine tare. page 30.](#)
2. Select the fertiliser type.
See [4.4.6: Fertiliser chart. page 44.](#)
3. Fill the hopper.
4. Weigh the fertiliser quantity in the hopper.
See [4.2.3: Weigh quantity. page 27.](#)
5. Start the work. If the hopper is empty, refill it. To do so, repeat steps 2 to 5.

NOTICE

If the hopper is **empty** and is filled with **less than 200 kg** of fertiliser, the flow factor is fixed and flow factor regulation does not take place ([4.4.3: Flow factor. page 36](#)). Change to operating mode **Auto Km/h**.

NOTICE

If the hopper is full and if **less than 200 kg** of fertiliser is added, push the **kg button** and **Weigh quantity** on the control panel at a standstill.

4.2.4 Machine tare

In this menu, set the weighing value for the empty weighing spreader to 0 kg.

NOTICE

The **Machine tare** menu item can only be requested if the fertiliser spreader being used is an **AXIS W**.

When supplying the control unit with the fertiliser spreader **AXIS W** this machine model is factory-set.

When taring the scales ensure that:

- the hopper is empty,
- the fertiliser spreader is at a standstill,
- the PTO shaft is switched off,
- the fertiliser spreader is horizontal and off the ground.
- the tractor is at a standstill

Tare scales:

1. Switch from the **Weighing-Tripcounter** menu to the **Machine Tare** menu.
▷ The **Machine tare** menu appears on the display.
2. Confirm with the **Enter button**.
▷ The weighing value for the empty scales is now set to 0 kg.
3. Press the **ESC key** to return to the **previous menu**.

NOTICE

Tare the scales before each use in order to ensure problem-free calculation of the **remaining fertiliser quantity**.

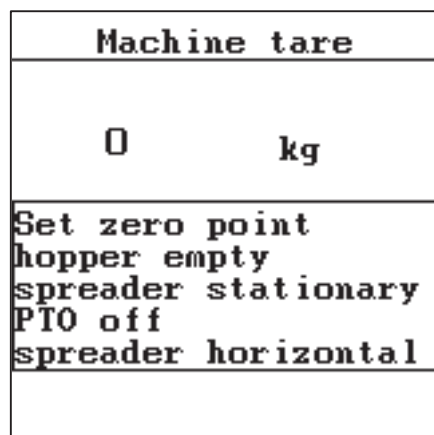

Figure 4.7: Machine tare

4.3 Main menu

- Press the **menu key** in the operating screen.
 - ▷ The main menu opens on the display.

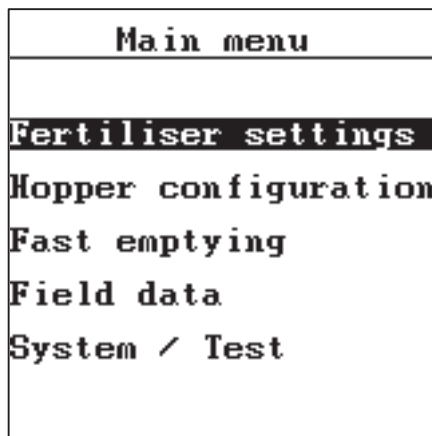

Figure 4.8: Quantron E Main menu

The main menu shows the following submenus.

Submenu	Meaning	Description
Fertiliser settings	Settings for fertiliser and spreader operation.	page 32
Hopper onfiguration	Settings for tractor and fertiliser spreader.	page 46
Fast emptying	Direct access to the menu for fast emptying of the fertiliser spreader.	page 60
Field data	Opens the menu for selecting, creating or deleting field data.	page 62
System / Test	Settings on the control unit.	page 66

How to select a submenu:

1. Highlight the submenu with the black bar in the display. The highlight bar can be moved up and down with the **arrow keys**.
2. Open the highlighted submenu with the **Enter key**.

4.4 Fertiliser settings

You make the settings for the fertiliser and spreader operation in this menu.

- Switch from the main menu to the **Fertiliser settings** menu.

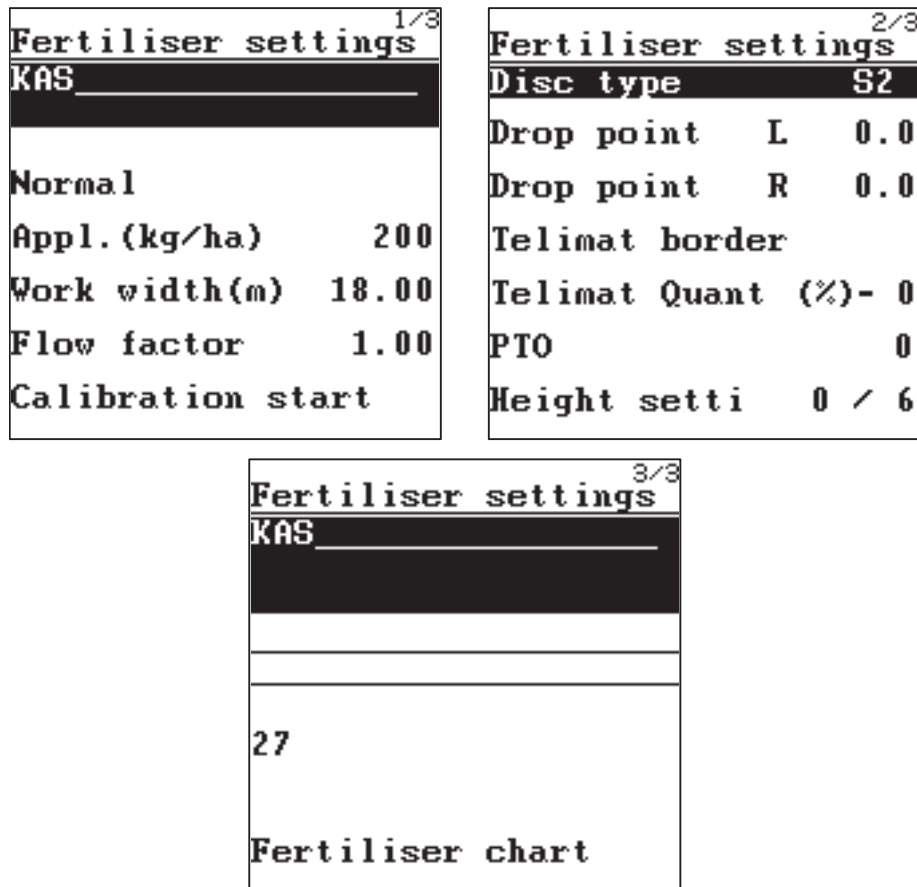

Figure 4.9: Fertiliser settings menu

Submenu	Meaning/Possible values	Description
Name of fertiliser	Selected fertiliser from private table.	page 44
Way to spread	Selection list: <ul style="list-style-type: none"> • Normal • Normal border • Normal boundary • Late • Late border • Late boundary 	Selection using arrow keys Confirmation with Enter key
Application rate	Input target value for the application rate in kg/ha.	page 34
Working width	Determination of the working width to be spread.	page 35
Flow factor	Input flow factor of the fertiliser used.	page 36

Submenu	Meaning/Possible values	Description
Calibration start	Request submenu for executing the calibration test.	page 38
Spreading disc type	Selection list: <ul style="list-style-type: none"> • S2 • S4 • S6 • S8 • S10 • S12 	Selection using arrow keys Confirmation with Enter key
Drop point L	Input of the left-hand drop point: the display is only for information. If the left-hand side is changed, the right-hand side changes to the same value automatically. For AXIS 50.1 W: electrical setting of the drop point	Observe the operating instructions for the fertiliser spreader page 43
Drop point R	Input of the right-hand drop point: the display is only for information. If the right-hand side is changed, the left-hand side changes to the same value automatically. For AXIS 50.1 W: electrical setting of the drop point	
Telimat border	Storing the Telimat settings for border fertilisation.	Only for fertiliser spreaders with Telimat sensor.
Telimat quantity	Pre-setting the quantity reduction when boundary fertilising.	
PTO shaft	540 rpm	
Height setting	Input in cm Freely editable number values	page 76
Name of fertiliser	Selected fertiliser from private table.	page 44
Manufacturer	Entering the manufacturer of the fertiliser.	page 44
Composition	Percentage content of the chemical composition.	page 44
Fertiliser chart	Management of fertiliser charts.	page 44

How to select a submenu:

1. Highlight the submenu with the black bar in the display. The highlight bar can be moved up and down with the **arrow keys**.
2. Open the highlighted submenu with the **Enter key**.

NOTICE

Not all parameters are shown simultaneously in one operating screen. You can jump to the adjacent operating screen with the **arrow keys**.

4.4.1 Application rate

In this menu you can enter the desired target value for the application rate.

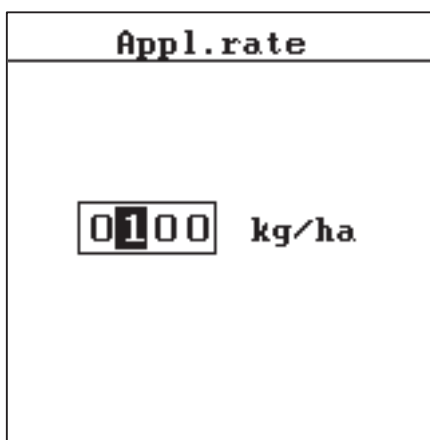

Figure 4.10: Appl.rate menu

Input application rate:

1. Switch from the **Fertiliser settings** menu to the **Application Rate** menu.
 - ▷ The display shows the **currently specified** application rate.
2. Input the new value in the input field with the arrow keys:
 - Arrow up:** Value increases.
 - Arrow down:** Value decreases.
 - Arrow to the left/right:** Cursor moves to the left/right.See also [4.9.2: Input of values using the cursor keys, page 76](#).
3. Confirm the input by pressing the **Enter key**.
 - ▷ The new value is saved in the operator panel.
4. Press the **ESC key** to return to the **previous menu**
or
Press the **Menu key** to return to the **Operating Screen**.

4.4.2 Working width

You can set the working width (in metres) in this menu.

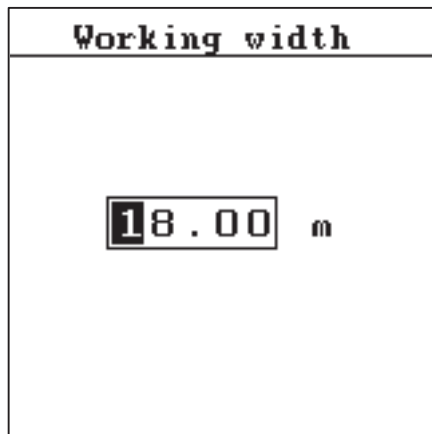

Figure 4.11: Working width menu

Entering the working width:

1. Switch from the **Fertiliser settings** menu to the **Working Width** menu
 - ▷ The **working width currently set** appears on the display.
2. Input the new value in the input field with the arrow keys:
 - Arrow up:** Value increases.
 - Arrow down:** Value decreases.
 - Arrow to the left/right:** Cursor moves to the left/right.
3. Confirm the input by pressing the **Enter key**.
 - ▷ **The new value is saved in the operator panel.**
4. Press the **ESC key** to return to the **previous menu**
or
Press the **Menu key** to return to the **Operating Screen**.

4.4.3 Flow factor

The flow factor is within the range of **0.4** to **1.9**. The following applies under the same basic conditions (km/h, working width, kg/ha):

- If **the flow factor is increased** the metering weight is **reduced**.
- If the flow factor is **reduced** the metering weight is **increased**.

If you know the flow factor from earlier calibration tests or from the fertiliser chart, you can input it **manually** in this menu.

NOTICE

The calibration menus ([page 38](#)) permit the flow factor to be determined with the aid of the Quantron E and entered.

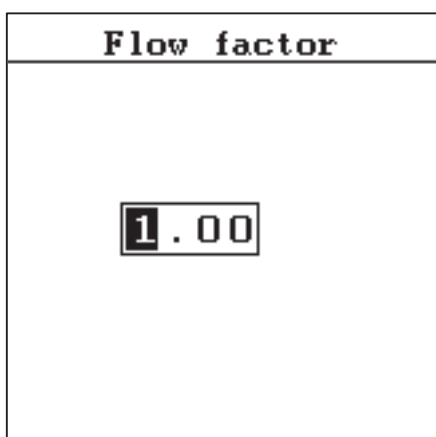

Figure 4.12:Flow factor menu

With the weighing spreader, the calculation of the flow factor is performed through dynamic weighing. However, the data can also be entered manually.

NOTICE

The flow factor calculation depends on the operating mode used. For further information about the flow factor, refer to section [4.5.2: AUTO / MAN mode, page 50](#).

Input flow factor:

1. Switch from the **Fertiliser settings** menu to the **Flow Factor** menu.
 - ▷ The display shows the **currently specified** flow factor.
2. Input the new value in the input field with the arrow keys:
 - Arrow up:** Value increases.
 - Arrow down:** Value decreases.
 - Arrow to the left/right:** Cursor moves to the left/right.

NOTICE

If your fertiliser is not listed in the fertiliser chart, input flow factor **1.00**.

In the **AUTO km/h operating mode**, we strongly recommend that you perform a **calibration** to precisely determine the flow factor for this fertiliser.

3. Confirm the input by pressing the **Enter key**.
 - ▷ **The new value is saved in the operator panel.**
4. Press the **ESC key** to return to the **previous menu**
 - or
 - Press the **Menu key** to return to the **Operating Screen**.

NOTICE

On AXIS W (**Auto km/h + Auto kg**), we recommend displaying the flow factor on the operating screen (see [4.8.2: Display config., page 68](#)) in order to observe the flow factor regulation during spreading.

See also [4.5.2: AUTO / MAN mode, page 50](#).

Resolving problems with the flow factor regulation (only AXIS W):

Under certain conditions, the display of the flow factor can freeze, despite having carried out the **Weigh quantity** function. The following alarm message appears in the display.

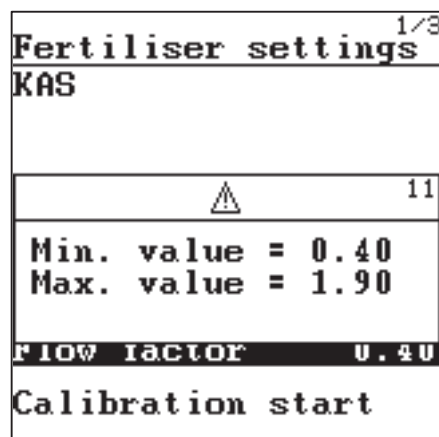

Figure 4.13: Flow factor error message

▲ CAUTION**Possible spreading error**

This alarm message can lead to spreading errors which have a negative impact on the environment.

- ▶ **Immediately stop** the spreading process.

Resolving the fault:

- See [5.2: Clear fault / alarm, page 79](#)

4.4.4 Calibration test

NOTICE

On the weighing spreader the **calibration test** menu is blocked in the **AUTO km/h + Auto kg** operating mode; the menu point cannot be selected.

In this menu, you can determine the flow factor on the basis of a calibration test and save it in the control unit.

Run the calibration test:

- Before spreading for the first time.
- If the fertiliser quality has changed greatly (moisture, high dust content, cracked grain).
- If a new fertiliser type is used.

The calibration test must be conducted (with engaged PTO shaft) at a standstill or during travel over a test section.

- Remove both the spreading discs and move the drop point to the calibration test position (Position 0).

⚠ CAUTION



Danger of injury caused by automatic adjustment of the drop point

On the **AXIS 50.1 W** the alarm **move to drop point** intervenes. After actuating the **Start/Stop** button, the drop point moves to the calibration test position (Position 0). After the calibration test the drop point is approached automatically by means of an electrical setting cylinder. This can cause injuries and material damage.

- ▶ Before actuating the **Start/Stop** button, ensure that no one is in the danger area of the machine.
-

Entering the working speed:

1. Switch from the **Fertiliser settings** menu to the **Calibration Test** menu.
2. Enter the average working speed.

This value is required for calculating the slide position during the calibration test.

3. Input the new value in the input field with the arrow keys:

Arrow up: Value increases.

Arrow down: Value decreases.

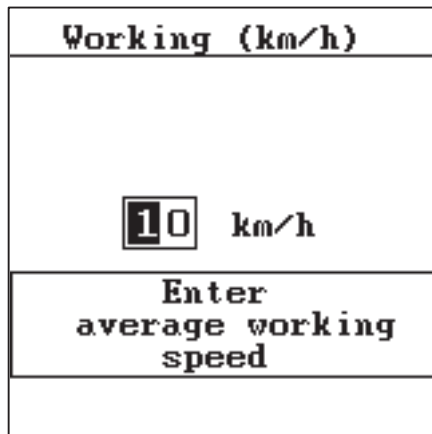

Figure 4.14: Working speed menu

4. Confirm the input by pressing the **Enter key**.
 - ▷ The new value is saved in the operator panel.
 - ▷ The **Prepare calibration test** screen opens.

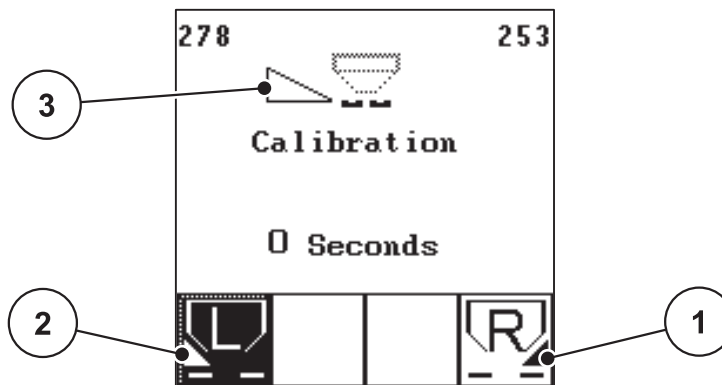

Figure 4.15: Prepare calibration test screen

- [1] Icon above function key F4 to select right spreading side
- [2] Icon above function key F1 to select left spreading side
- [3] Display of part width

Select part width:

1. Set the spreading side on which you wish to conduct the calibration test.
 - Press function key **F1** to select the spreading side **left** or
 - Press function key **F4** to select the spreading side **right**.
- ▷ **The symbol of the selected spreader side has a black background.**

Running calibration test:

▲ WARNING



Risk of injury when performing the calibration

Rotating machine components and discharged fertiliser may cause injury.

- ▶ **Before starting** the calibration test make sure that all requirements have been met. Follow the **Calibration** section in the operating manual for the fertiliser spreader.

2. Press the **Start/Stop** button.

- ▷ The opening slide of the previously selected part width is opened. The calibration test is started.
- ▷ The **Run calibration test** screen is displayed.

NOTICE

The calibration test can be stopped at any time by pressing the **ESC key**. The opening slide is then closed and the **Fertiliser Settings** menu appears in the display.

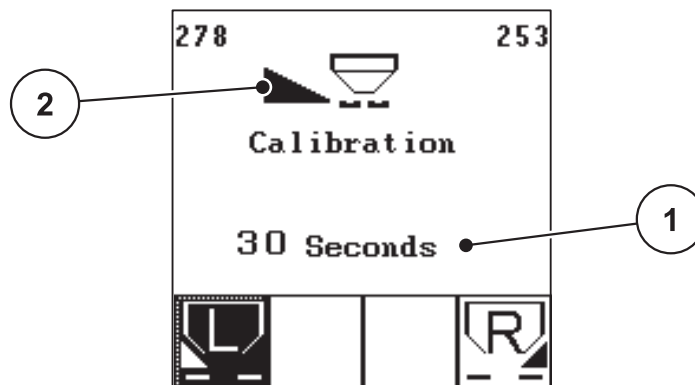

Figure 4.16:Running calibration test operating screen

- [1] Display of elapsed time since starting the calibration test
- [2] Part width (in this case: left hand) active

NOTICE

The calibration test time is not relevant to the accuracy of the results. However, **at least 20 kg** must be spread.

3. In order to end the calibration test, press the **Start/Stop** key again.

- ▷ The opening slide is closed.
- ▷ The **Input collected weight** menu is displayed.

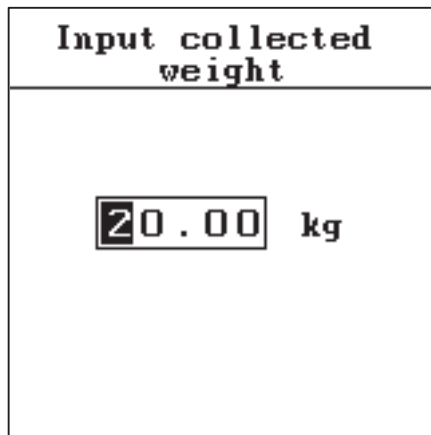

Figure 4.17: Input collected weight menu

⚠ WARNING



Risk of injury from rotating machine components

Contact with rotating machine components (shafts, hubs) may cause bruises, abrasions and crushing injuries. Body parts or objects may be caught or pulled in.

- ▶ Disengage the PTO shaft and the tractor engine and lock them to prevent unauthorised activation.

Recalculate flow factor

1. Weigh the spread fertiliser amount.
2. Input the weight of discharged fertiliser in the input field of the **Input collected weight** menu.

See also [4.9.2: Input of values using the cursor keys, page 76](#).

3. Confirm the input by pressing the **Enter key**.
 - ▷ The new value is saved in the operator panel.
 - ▷ The display shows the **Flow Factor Calculation** menu.

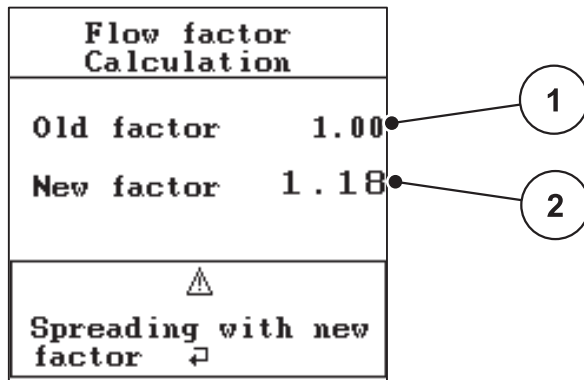

Figure 4.18:Flow factor calculation menu

- [1] Display of previously saved flow factor
 [2] Display of new calculated flow factor

4. Specify the flow factor.

To accept the **newly calculated** flow factor press the **Enter key**.

To confirm the **previously saved** flow factor press the **ESC key**.

- ▷ **The flow factor is saved.**
- ▷ **The Fertiliser Settings menu is displayed.**

⚠ CAUTION



Danger of injury caused by automatic adjustment of the drop point

On the **AXIS 50.1 W** the alarm **move to drop point** intervenes. After actuating the **Start/Stop** button, the drop point is automatically approached using the electrical setting cylinder to the pre-set value. This can cause injuries and material damage.

- ▶ Before actuating the **Start/Stop** button, ensure that no one is in the danger area of the machine.

5. Press the **ESC key** to return to the **previous menu**

or

Press the **Menu key** to return to the **Operating Screen**.

4.4.5 Drop point (L+R)

When the Quantron E is connected to an **AXIS 50.1 W** fertiliser spreader, the drop point is actuated and adjusted electrically.

NOTICE

Entering the drop point with the **AXIS 20.1**, **AXIS 30.1** or **AXIS 40.1** is merely informative and does not affect the settings on the fertiliser spreader.

1. Switch from the **Fertiliser settings** menu to the **drop point L** menu.
2. Determine the position for the drop point from the fertiliser chart.
3. Input the determined value in the input field with the arrow keys:
 - Arrow up:** Value increases.
 - Arrow down:** Value decreases.
4. Press the **Enter key**.
 - ▷ A message appears in the display asking for the new setting to be confirmed.

See [5.1: Meaning of alarm messages, page 77](#)

▲ CAUTION



Danger of injury caused by automatic adjustment of the drop point!

On the **AXIS 50.1 W** the alarm **move to drop point** intervenes. After actuating the **Start/Stop** button, the drop point is automatically approached using the electrical setting cylinder to the pre-set value. This can cause injuries and material damage.

- ▶ Before actuating the **Start/Stop** button, ensure that no one is in the danger area of the machine.

The fertiliser settings window appears in the display with the new drop point (L and R).

NOTICE

Emergency actuation on the **AXIS 50.1** must not stop the adjustment of the drop point. Otherwise the setting unit for the drop point can suffer damage.

If the drop point is blocked Alarm 17 appears; See [5.1: Meaning of alarm messages, page 77](#).

4.4.6 Fertiliser chart

You can create and manage **fertiliser charts** in this menu.

NOTICE

The selection of a fertiliser chart has an effect on the fertiliser settings, the control unit and the fertiliser spreader. The setting of the application rate remains unaffected.

Create new Private Fertiliser Chart

You have the option of creating up to **60** Private Fertiliser Charts in the control unit.

1. Switch from the **Fertiliser settings** menu to the **Fertiliser chart** menu.
 - ▷ The display shows the number of existing fertiliser charts.

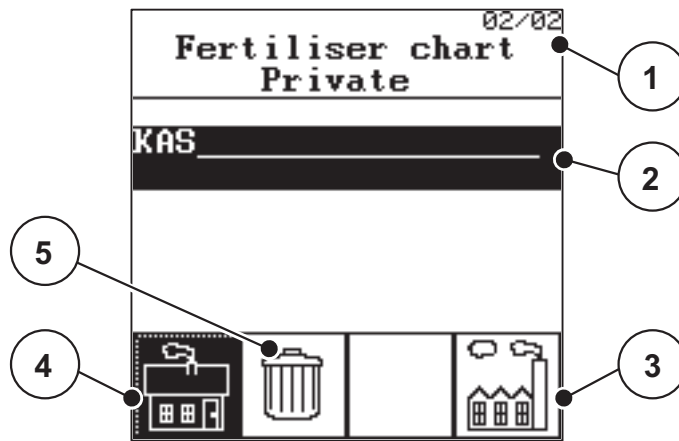

Figure 4.19: Display of existing fertiliser charts (private)

- [1] Number of the private table/Number of stored tables
- [2] Name field
- [3] Working table
- [4] Private table
- [5] Delete the displayed private table

2. Push the **F4** button (working table)
 - ▷ A new table with an empty name is created.
 - ▷ In the display the number of existing tables increases.
3. Highlight the (empty) **Name Field**.
4. Press the **Enter** key.
 - ▷ The **Fertiliser Settings** menu is displayed again.
5. Press the **Enter** key.
 - ▷ The **Fertiliser name** menu is displayed.
6. Enter the name of fertiliser chart by using the **navigation keys** and the **enter key**.

Input of text into the operator panel is described in section [4.9.1: Text input, page 75](#).

NOTICE

We recommend naming the fertiliser chart with the fertiliser name to improve the classification of the fertiliser chart.

7. Confirm the name input with the **F4** key (OK).

- ▷ The name of the fertiliser chart is saved in the operator panel.
- ▷ The **Fertiliser Settings** menu is displayed again.

The steps for specifying the other parameters are described in the section: [Edit fertiliser chart, page 45](#).

Selecting existing fertiliser chart:

1. Switch from the **Fertiliser settings** menu to the **fertiliser chart** menu.
 - ▷ The **Fertiliser Chart Private** operating screen is displayed.
2. Select the fertiliser chart with the arrow keys and push the **Enter Button**.
 - ▷ **The Fertiliser Settings menu is displayed in the operating screen.**

NOTICE

A private fertiliser chart is saved during the initial commissioning of the control unit. The display of existing fertiliser charts shows **1/1** and the name field is **blank** (see: [Create new Private Fertiliser Chart, page 44](#)).

3. Select the desired fertiliser chart in the **name field**.

You can move up and down the list of existing fertiliser charts with the **arrow keys**.
4. Confirm the selection of a fertiliser chart by pressing the **Enter key**.
 - ▷ **The Fertiliser Settings menu is displayed.**

Edit fertiliser chart

1. Select the desired fertiliser chart in the **fertiliser chart** operating screen and confirm the selection with the **Enter key**.
 - ▷ The **Fertiliser Settings** menu is displayed.
2. Process the parameters in the **Fertiliser Chart**.

See [4.4: Fertiliser settings, page 32](#)

4.5 Hopper configuration

You make the settings for the tractor and the fertiliser spreader in this menu.

- Switch from the main menu to the **Hopper configuration** menu.

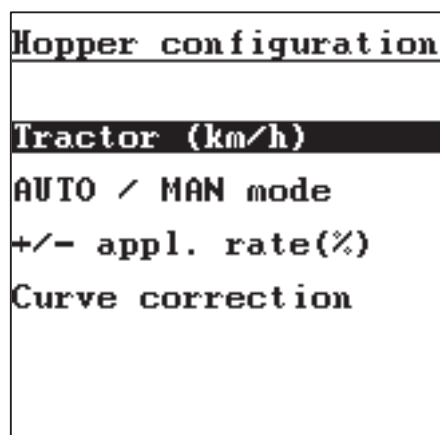

Figure 4.20: Hopper configuration menu

Submenu	Meaning	Description
Tractor (km/h)	Determination or calibration of the speed signal.	page 47
AUTO / MAN mode	Determination of the operating mode automatic or manual.	page 50
+/- appl. rate	Pre-setting of the volume reduction for the different spreading types.	page 59
Curve correction	Input of a correction value in order to maintain the spreading volume when there are different mass flows.	page 59

How to select a submenu:

1. Highlight the submenu with the black bar in the display. The highlight bar can be moved up and down with the **arrow keys**.
2. Open the highlighted submenu with the **Enter key**.

4.5.1 Speed calibration

The speed calibration is the basic requirement for an exact spreading result. Factors such as tyre size, a different tractor, all-wheel drive ON or OFF, slippage between tyres and ground, ground characteristics and tyre pressure influence the speed measurement and therefore the spreading result.

Preparing for speed calibration:

The exact calculation of the number of speed impulses over 100 m is very important for precise discharge of the weight of fertiliser.

- Run the calibration in the field. This reduces the influence of the ground characteristics on the calibration result.
- Measure a **100 m** reference distance as accurately as possible.
- Engage four-wheel drive.
- No more than half fill the fertiliser spreader.

Opening speed settings:

In the control unit Quantron E, up to **4 different profiles** for type and number of impulses can be saved. You give the profiles names (e. g. tractor name).

Before spreading, check that the correct profile is open in the control unit.

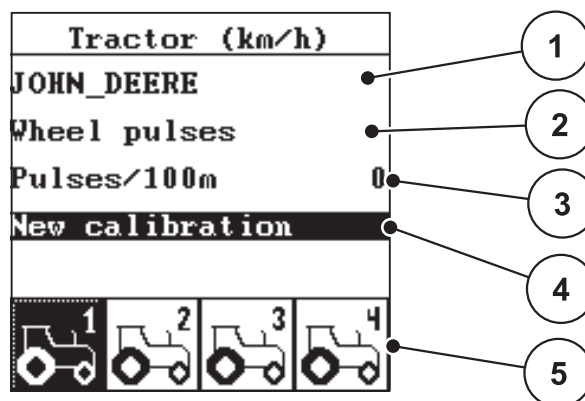

Figure 4.21: Tractor (km/h) menu

- [1] Tractor type
- [2] Transducer display for the speed signal
- [3] Display of number of impulses over 100 m
- [4] Calibrate tractor submenu
- [5] Icons for memory locations of profiles 1 to 4

1. Switch from the **Hopper configuration** menu to the **Tractor (km/h)** menu.
 - ▷ The display values for name, origin and number of impulses refers to the profile highlighted in black.
2. Push the function button (F1-F4) under the saving location symbol to switch the tractor profile.

Recalibrating the speed signal:

You can overwrite an existing profile or create a profile in an empty memory location.

1. Highlight the desired memory location with the function key below it in the **Tractor (km/h)** menu.
 2. In the **Tractor (km/h)** menu, highlight the **New Calibration** field using the **Arrow Keys**.
 3. Press the **Enter** key.
- ▷ **The calibration menu Tractor (km/h) is displayed.**

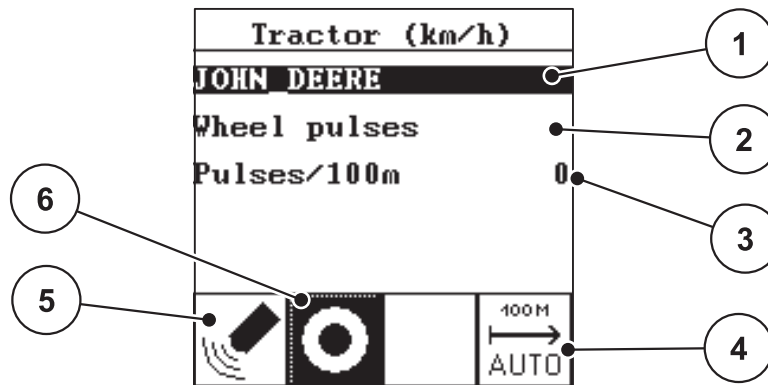

Figure 4.22: Tractor (km/h) calibration menu

- [1] Tractor name field
- [2] Display origin of speed signal
- [3] Display of number of impulses over 100 m
- [4] Automatic calibration submenu
- [5] Radar impulse transducer
- [6] Wheel impulse transducer

4. Highlight the **tractor name field** and press the **Enter** key.
5. Input the name of the profile.

NOTICE

The name is limited to **16 characters**.

We recommend using the name of the tractor for ease of understanding.

Input of text into the operator panel is described in section [4.9.1: Text input](#), page 75.

6. Select the transducer for the speed signal.
 - For **radar impulses** press the function key **F1**.
 - For **wheel impulses** press the function key **F2**.
- ▷ **The transducer is shown in the display.**

The number of impulses of the speed signal must still be specified below. If you know the exact number of impulses you can enter it directly:

7. Highlight the **Imp/100m** submenu and press the **Enter** key.

▷ **The Impulses menu is displayed for manual input of the number of impulses.**

Input of values into the operator panel is described in section [4.9.2: Input of values using the cursor keys, page 76](#).

If you do not know the exact number of impulses, you can start the calibration run.

8. Highlight the submenu **Imp/100m**

9. Press the function key **F4 (Auto)**.

▷ The calibration run operating screen is shown in the display.

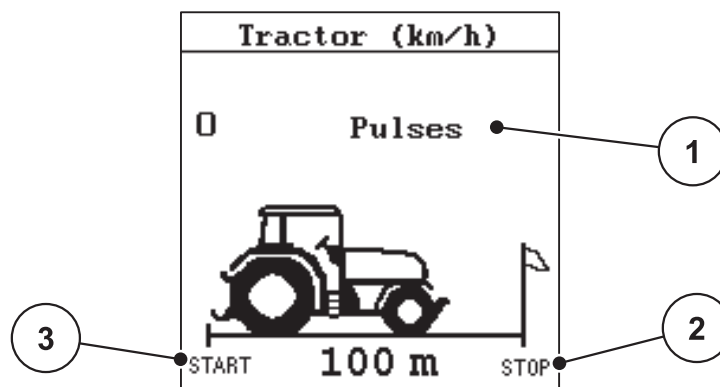

Figure 4.23: Calibration run speed signal operating screen

[1] Impulse display

[2] Stop recording impulses

[3] Start recording impulses

10. At the start of the reference distance press the function key **F1** below the **Start icon**.

▷ The impulse display is set to zero.

▷ The control unit is ready for counting impulses.

11. Drive the 100 m reference distance. Stop the tractor at the end of the reference distance.

12. Press the function key **F4** below the **Stop icon**.

▷ The display shows the number of received impulses.

13. Press the **Enter** key.

▷ The new impulse count is saved. This returns you to the Calibration menu.

14. Press the **ESC** key to return to the **previous menu**

or

Press the **Menu** key to return to the **Operating Screen**.

4.5.2 AUTO / MAN mode

By default you operate in **AUTO** mode. The control unit automatically controls the actuators as specified by the speed signal.

Only work in **manual** mode if:

- there is no speed signal (radar or wheel sensor not available or defective),
- seed auger or seeds (fine seeds) are to be discharged.

NOTICE

When working in manual mode you must always operate at a **constant ground speed** to ensure even spreading.

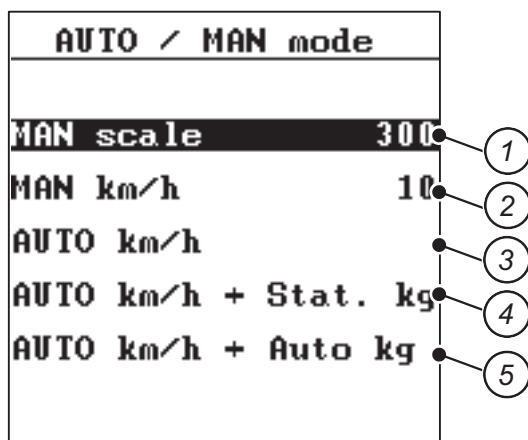

Figure 4.24: AUTO/MAN mode menu

- [1] Metering slide adjustment for manual mode
- [2] Adjustment of ground speed for manual mode
- [3] Selecting automatic mode
- [4] Selecting automatic mode with static weighing
- [5] Selecting automatic mode with automatic weighing

Automatic mode with automatic weighing (AUTO km/h + Auto kg)

The **AUTO km/h + Auto kg** operating mode allows for continuous weighing of the fertiliser volume in the hopper during spreader operation. The regulation of the flow factor is corrected at regular intervals on the basis of this information. This optimises the metering of the fertiliser.

NOTICE

The **AUTO km/h + Auto kg** menu only appears on the display if the **AXIS W** fertiliser spreader has been configured in the factory.

With the **AXIS W** setting, the **AUTO km/h + Auto kg** operating mode is preselected as standard at the factory.

a) Select Auto km/h + Auto kg:

1. Switch on the control unit Quantron E.
2. Switch from the **Hopper configuration** menu to the **AUTO/MAN operation** menu.
3. Highlight the **AUTO km/h + Auto kg** selection field.
4. Press the **Enter key**.
 - ▷ The **Weigh Quantity** window appears.
5. **Case a: Refill**
 - ▷ The flow factor setting is retained.
 - ▷ The remaining fertiliser volume is increased by the refilling volume.
- Case b: New fertiliser**
 - ▷ The flow factor is reset to 1. If necessary, you can enter the required flow factor value later on. See [4.4.3: Flow factor, page 36](#).
6. Highlight the required type of filling and press the **Enter key** to return to the **operating screen**.

▲ CAUTION**Incorrect metering by pressing the ESC key**

You must not press the ESC key. Doing so will result in serious errors in the application rate/metering.

- ▶ To confirm the weighing function, always press the **Enter key**.

b) Procedure when spreading with Auto km/h + Auto kg:

1. Each time you switch on the Quantron E, use the **kg** button to switch to the **Weigh Quantity** menu and weigh the volume of fertiliser using **Refill** or **New Fertiliser**.
See [4.2.3: Weigh quantity, page 27](#)
2. Press the **Enter key**.
3. Carry out the fertiliser settings:
 - Application rate (kg/ha)
 - Working width (m)
4. Pour the fertiliser in.

NOTICE

If the volume of fertiliser added to an empty hopper is less than 200 kg, switch to the **AUTO km/h + Stat. kg** or **Auto km/h** mode.

- ▷ The **Weigh Quantity** window appears in the display.

5. Highlight the action carried out in the display:
 - **Refill:**
Continue spreading with the same fertiliser.
The flow factor setting is retained.
The remaining fertiliser volume is increased by the refilling volume
 - **New fertiliser:** Flow factor set to 1.0 and a new flow factor regulation will follow.
 - **ESC:** Quit
- ▷ **The remaining fertiliser volume is increased by the refilling volume.**
6. Press the **Start/Stop** key.
 - ▷ **The spreading starts.**

NOTICE

On uneven, hilly terrain, application rates below 30 kg/min should be spread in the **Auto km/h + Stat. kg** (weighing spreader) or **Auto km/h** (other fertiliser spreader types) mode.

NOTICE

If, after confirming the **Weigh Quantity** window the fertiliser settings are changed before starting spreading, then these changes to the settings should be carried out with the spreader stopped and horizontal.

NOTICE

If, during running (i. e. travelling to the field) a change is made to the fertiliser settings, before starting to spread you must actuate the **kg/Weigh Quantity** button with the vehicle stopped.

NOTICE

We recommend that the flow factor be displayed in the operating screen (see [4.8.2: Display config.. page 68](#)), in order to watch the flow factor regulation whilst spreading.

NOTICE

In the event of problems with the regulating behaviour of the flow factor (blockages, ...), at a standstill and after resolution of the fault use the **kg** button to switch to the **Weigh Quantity** menu and call up the **New Fertiliser** function.

Automatic mode with static weighing (AUTO km/h + Stat. kg)

The **AUTO km/h + Stat. kg** operating mode is recommended for spreading on uneven hilly terrain and/or for low application rates. Automatic flow factor regulation does not take place during spreading. However, you can use the **Weigh Remnant** function to recalculate the flow factor.

NOTICE

The **AUTO km/h + Stat. kg** menu only appears on the display if the **AXIS W** fertiliser spreader has been configured in the factory.

a) Select Auto km/h + Stat. kg:

1. Switch on the control unit Quantron E.
 2. Fill the hopper with fertiliser.
 3. Switch from the **Hopper configuration** menu to the **AUTO/MAN operation** menu.
 4. Highlight the **AUTO km/h + Stat. kg** selection field
 5. Press the **Enter key**.
 - ▷ The **Weigh Quantity** window appears.
 6. Confirm the **New fertiliser** selection field with the **Enter key**.
 - ▷ The flow factors is reset to 1.0.
- ▷ **The control unit switches to the operating screen.**

b) Procedure when spreading with Auto km/h + Stat. kg:

1. Each time you switch on the Quantron E, use the **kg** button to switch to the **Weigh Quantity** menu and weigh the volume of fertiliser using **Refill** or **New Fertiliser**.

See [4.2.3: Weigh quantity, page 27](#)

2. Press the **Enter** key.
 3. Carry out the fertiliser settings:
 - Application rate (kg/ha)
 - Working width (m)
 4. Pour the fertiliser in.
 - ▷ The **Weigh Quantity** window appears in the display.
 5. Highlight the action carried out in the display:
 - Refill:** Continue spreading with the same fertiliser. All stored values (flow factor) are retained.
 - New fertiliser:** Flow factor is reset to 1.0. If necessary, you can enter the required flow factor value later on.
- ESC** Quit
6. Press the **Enter** key.
 7. Refer to the fertiliser chart or empirical values for the flow factor and enter it manually.
 8. Press the **Start/Stop** button.
 - ▷ The spreading starts.
 9. After at least 150 kg of fertiliser has been discharged, press the **Start/Stop** button.
 10. Stop the tractor on a level surface.
 - The fertiliser spreader must be horizontal.
 11. Switch to the **Weigh Quantity** menu using the **kg** key.
 12. Highlight the **Weigh remnant** selection field.
 13. Press the **Enter** key.
 - ▷ The quantity discharged is compared with the actual remaining fertiliser volume in the hopper.
 - ▷ The flow factor is then recalculated accordingly.
 14. Specify the flow factor.
 - To accept the **newly calculated** flow factor, press the **Enter** key.
 - To accept the **previously saved** flow factor, press the **ESC** key.

▲ CAUTION**Danger of injury caused by automatic adjustment of the drop point**

On the **AXIS 50.1 W** the alarm **move to drop point** intervenes. After actuating the **Start/Stop** button, the drop point is automatically approached using the electrical setting cylinder to the pre-set value. This can cause injuries and material damage.

- ▶ Before actuating the **Start/Stop** button, ensure that no one is in the danger area of the machine.

NOTICE

If, during running (i. e. travelling to the field) a change is made to the fertiliser settings, before starting to spread you must actuate the **kg/Weigh Quantity** button with the vehicle stopped.

Automatic Mode (Auto km/h)**a) Select Auto km/h:**

1. Switch on the control unit Quantron E.
2. Switch from the **Hopper configuration** menu to the **AUTO/MAN operation** menu.
3. Highlight the **AUTO km/h** selection field.
4. Press the **Enter key**.
 - ▷ The operating mode setting is saved.
5. Press the **ESC key** to return to the **previous menu**
 - or
 - Press the **Menu key** to return to the **Operating Screen**.

b) Procedure when spreading with Auto km/h:

1. Carry out the fertiliser settings:
 - Application rate (kg/ha)
 - Working width (m)
 2. Pour the fertiliser in.
 3. Carry out a calibration test to determine the flow factor
or
Take the flow factor from the fertiliser chart and enter it manually.
 4. Press the **Start/Stop** button.
- ▷ **The spreading starts.**

NOTICE

In order to achieve an optimum spreading result you should carry out a calibration test before starting to spread.

Manual Operation (MAN km/h)

1. Switch from the **Hopper configuration** menu to the **AUTO/MAN operation** menu.
2. Highlight the **MAN km/h** selection field.
- ▷ **The Forward speed menu is displayed.**
3. Input the value for the forward speed during spreading. Confirm the input by pressing the **Enter key**.
4. Press the **ESC key** to return to the **previous menu**
or
Press the **Menu key** to return to the **main menu**.

NOTICE

The specified operating mode is displayed in the operating screen.

Manual Operation Scale (MAN Scale)

NOTICE

For an optimum spreading result in manual mode as well, we recommend using the values for metering slide opening and ground speed in the fertiliser chart.

1. Switch from the **Hopper configuration** menu to the **AUTO/MAN operation** menu.
2. Highlight the **MAN scale** selection field.
- ▷ **The slide opening menu is displayed.**
3. Input the scale value for the metering side opening. Confirm the input by pressing the **Enter key**.

Input of values into the operator panel is described in section [4.9.2: Input of values using the cursor keys, page 76](#).
4. Press the **ESC key** to return to the **previous menu**.
or
Press the **Menu key** to return to the **Operating Screen**.

NOTICE

The specified operating mode is displayed in the operating screen.

The metering slide opening can be changed manually during spreader operation in the **MAN scale** mode.

Requirement:

- The metering slides are open (activation with the **Start/Stop key**).
- In the **MAN Scale** operating screen, the symbols for the part widths are filled in black.

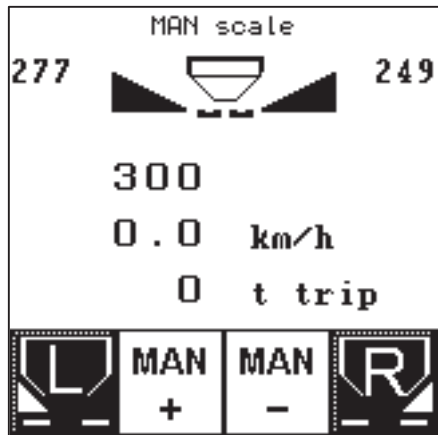

Figure 4.25:MAN scale operating screen

5. To change the metering slide opening press the function key **F2** or **F3**.
F2: MAN+ to increase the metering slide opening or
F3: MAN- to reduce the metering slide opening.

4.5.3 +/- appl. rate

In this menu, you can specify a percentage **volume change** for the normal spreading type.

The basis (100 %) is the pre-set value of the dispensing slider opening.

NOTICE

During operation you can use the button F2/F3 to change the spreading volume by the factor of the +/- volume at any time.

Use the button **100 %** to restore the pre-set values again.

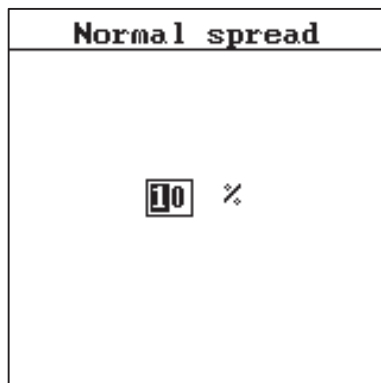

Figure 4.26: +/- appl. rate (%) menu

Specifying weight reduction:

1. Switch from the **Hopper configuration** menu to the **+/- appl. rate** menu.
2. Enter the percentage value by which you wish to modify the spreading volume.

Input of values into the operator panel is described in section [4.9.2: Input of values using the cursor keys, page 76](#).

3. Press the **Enter key**.

4.5.4 Curve correction

The fully enclosing spreading disc protector creates a vacuum effect when the spreading disc rotates, which leads to deviation from the target application volume. The suction effect is greater with low mass flows (small metering slide opening) than with large mass flows.

By entering the curve correction, you can counter this effect.

NOTICE

The curve correction should **under normal conditions** always be set to **0**.

4.6 Fast emptying

The **Fast emptying** menu can be selected to clean the machine after spreading or to discharge the remaining weight quickly.

NOTICE

Before starting fast emptying make sure that all requirements have been met. Observe the operating instructions for the fertiliser spreader (fast emptying).

- Switch from the main menu to the **Fast emptying** menu.

CAUTION



Danger of injury caused by automatic adjustment of the drop point

On the **AXIS 50.1 W** the alarm **move to drop point** intervenes. After actuating the **Start/Stop** button, the drop point moves to the calibration test position (AGP 0). The drop point is then approached automatically using an electric setting cylinder. This can cause injuries and material damage.

- ▶ Before actuating the **Start/Stop** button, ensure that no one is in the danger area of the machine.

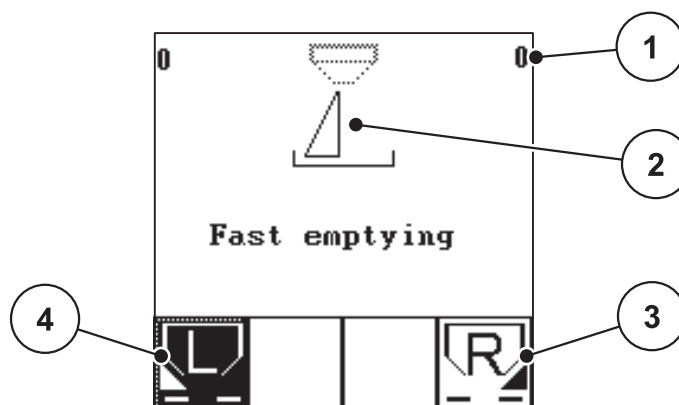

Figure 4.27:Fast emptying menu

- [1] Metering slide opening display
- [2] Icon for fast emptying (here: left side selected but not started)
- [3] Fast emptying right-hand part width (in this case: not selected)
- [4] Fast emptying left-hand part width (in this case: selected)

Run fast emptying:

1. Use the **Function Button** to select the desired part width.
 - ▷ The selected part width is shown as a symbol in the display.
2. Press the **Start/Stop button**.
 - ▷ Fast emptying is started.
3. To stop fast emptying, press the **Start/Stop button again**.

▲ CAUTION**Danger of injury caused by automatic adjustment of the drop point**

On the **AXIS 50.1 W** the alarm **move to drop point** intervenes. After actuating the **Start/Stop** button, the drop point is automatically approached using the electrical setting cylinder to the pre-set value. This can cause injuries and material damage.

- ▶ Before actuating the **Start/Stop** button, ensure that no one is in the danger area of the machine.

-
4. Press the **ESC key** to return to the **main menu**.

4.7 Field data

In this menu you can create and save up to **200 operating data files**.

- Switch from the main menu to the **Field Data** menu.

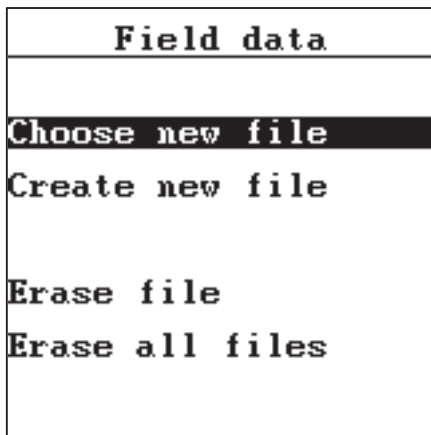

Figure 4.28:Field file menu

Submenu	Meaning	Description
Choose new file	Selects a field file which is already saved.	page 62
Create new file	Creates a new field file.	page 63
Erase file	Deletes the highlighted field file.	
Erase all files	Deletes all saved operating data.	

4.7.1 Select field file

You can re-select a previously saved field file and proceed with this. The data already stored in the field file is **not overwritten** in doing so, but rather are **added to** with the new values.

1. In the **Field Data** menu, select the **Select New File** entry and press the **Enter key**.
 - ▷ The display shows the already saved operating data **sorted alphabetically**.
2. Select the desired field and press the **Enter key**.
 - ▷ The display shows the first page of the current field file.

To accept a field file, see [4.7.3: Starting recording. page 63](#).

4.7.2 Creating a new field file

1. In the **Field data** menu, select the **Create New File** entry and press the **Enter key**.
 - ▷ The display shows a window for entering the file name or a note.
 - Input of text into the operator panel is described in section [4.9.1: Text input, page 75](#).

NOTICE

The name is limited to **40 characters**.

2. Press the **F4 (OK)** function key to confirm the entry into the name field.
 - ▷ The display shows the first page of the current field data.
 - ▷ You can change the name of the field data by marking the second line.

4.7.3 Starting recording

1. Switch from the **Field data** menu to the current field file.

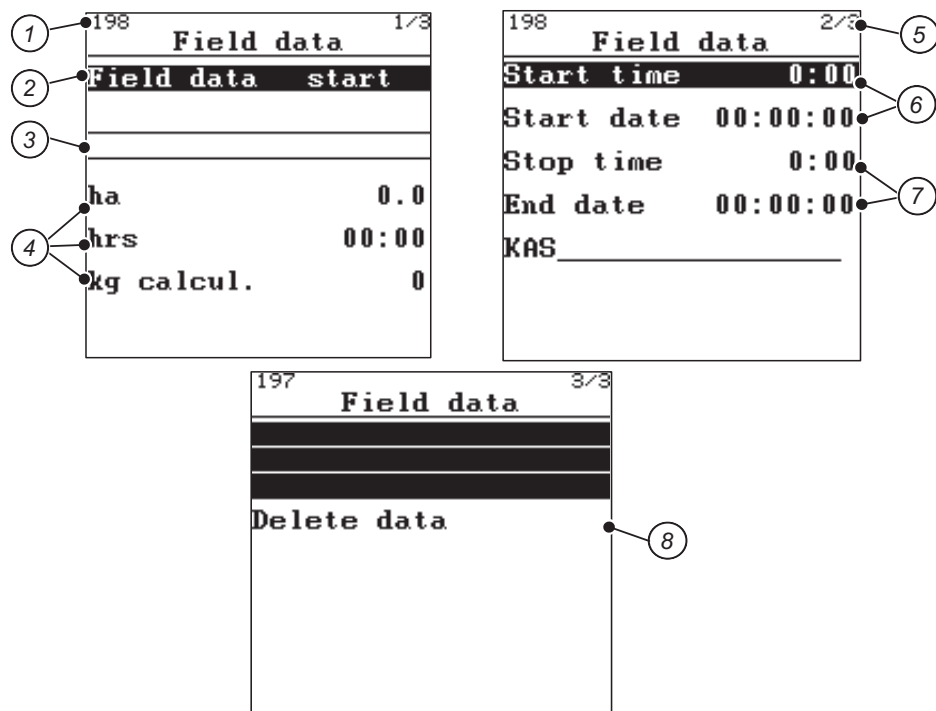

Figure 4.29: Displaying the field data

- [1] Display of remaining free memory locations
- [2] Field for starting recording
- [3] Name field
- [4] Value fields
- [5] Display of the page number
- [6] Display of the start time/date
- [7] Display of the stop time/date
- [8] Field for deleting the data of the current field data

2. Select the **Field data start** field and press the **Enter key**.
 - ▷ Recording starts.
 - ▷ The **Field data start** display changes to **Field data stop**.
 - ▷ The **operating screen** displays the **recording icon**.

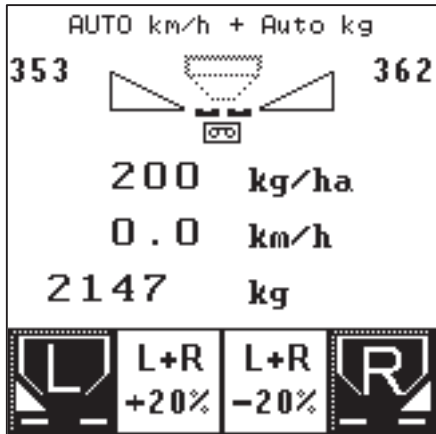

Figure 4.30:Recording symbol

3. Press the **ESC key** to return to the **previous menu**
or
Press the **Menu key** to return to the **Operating Screen**.

4.7.4 Stopping recording

1. Switch from the **Field data** menu to the current field data.
2. In the current field data select the **Field data stop** field and press the **Enter key**.
 - ▷ The recording is stopped.
 - ▷ The **Field data stop** display changes to **Field data start**.
3. Press the **ESC key** to return to the **previous menu**
or
Press the **Menu key** to return to the **Operating Screen**.

4.7.5 Importing and exporting operating data

The control unit Quantron E enables the operating data recorded to be imported or exported.

- See [4.8.4: Data transmission, page 71](#).

4.8 System / Test

This menu is used to created the test and system settings for the control unit.

- Switch from the main menu to the **System / Test** menu.

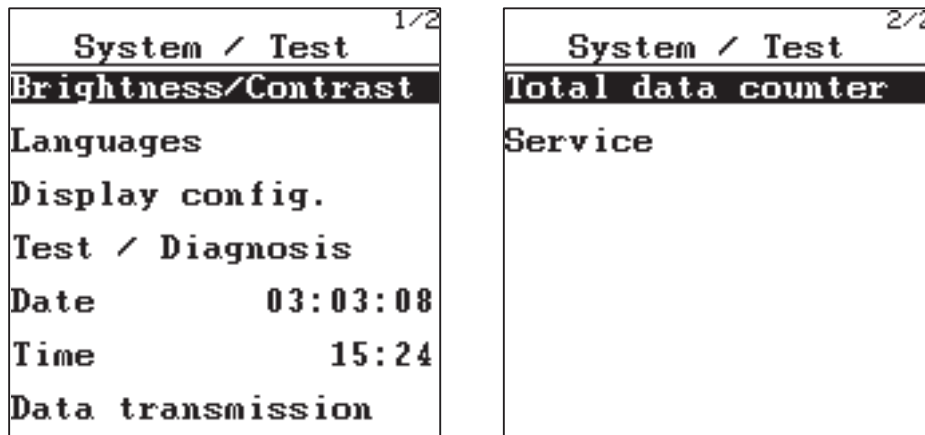

Figure 4.31: System/Test menu pages 1 and 2

Submenu	Meaning	Description
Brightness / Contrast	Display setting.	Modification of the setting with the function keys + or -.
Languages	Language setting for the menu guide.	page 67
Display config.	Determination of the displays on the operating screen.	page 68
Test / Diagnosis	Check of actuators and sensors.	page 69
Date	Setting the current date.	
Time	Setting the current time.	
Data transmission	Menu for exchanging data with the control unit and storing the operating data using a PC.	page 71
Total data counter	Display and delete total <ul style="list-style-type: none"> • spread quantity in kg • spread area in ha • spread time in h • distance travelled in km 	A release code is required to delete all data. Deletion only to be carried out by service personnel.
Service	Service settings	Password-protected; Only accessible to service personnel

How to select a submenu:

1. Highlight the submenu with the black bar in the display.
The highlight bar can be moved up and down with the **arrow keys**.
2. Open the highlighted submenu with the **Enter key**.

4.8.1 Setting language

In the control unit Quantron E there are **2 different language packages** possible. Each language package covers 12 predefined languages.

The language package for your country is preloaded in the factory.

1. Switch from the **System / Test** menu to the **Languages** submenu.
▷ The display shows the first page of the **Language selection** submenu.



Figure 4.32: Menu language selection, pages 1 and 2, first language package

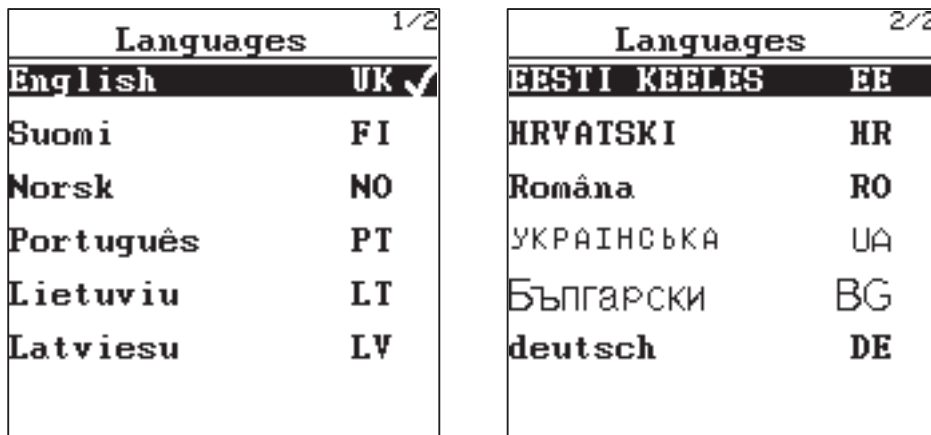

Figure 4.33: Menu language selection, pages 1 and 2, second language package

2. Select the language for the menus and confirm the selection with the **Enter key**.
3. The control unit Quantron E restarts automatically.

NOTICE

If you require a different language package please contact your dealer.

4.8.2 Display config.

The display fields in the operating screen of the control unit can be configured as required. You can assign both display fields with the following values if desired:

- Ground speed
- Flow factor (FF)
- Time
- ha trip
- kg trip
- m trip
- kg rest
- m rest
- ha rest

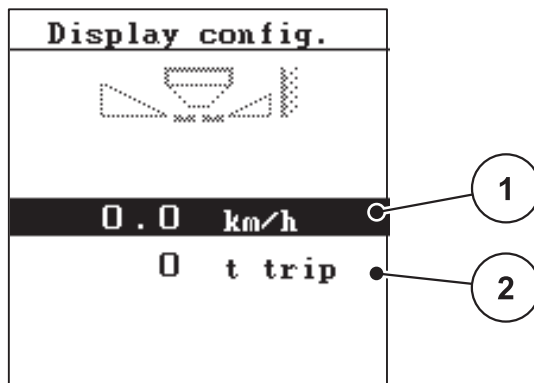

Figure 4.34: Display config. menu

- [1] Display field 1
- [2] Display field 2

Select display (example display field 1)

1. Switch from the **System / Test** menu to the **Display config.** submenu.
2. Highlight the **display field 1** and press the **Enter key**.
 - ▷ The possible displays are listed in the display.
3. Highlight the new value that the display field should use. Press the **Enter key**.
 - ▷ The **Operating Screen** is displayed. The new value is input in **display field 1**.
4. Press the **Menu key** to return to the **Display config.** menu and then press the **ESC key**
or
Press the **Menu key** to return to the **Operating Screen**.

4.8.3 Test / Diagnosis

In the **Test/Diagnosis** menu you can monitor the function of certain sensors/actuators.

NOTICE

This menu serves only for information purposes.

The list of the sensors depends upon the equipment level of the machine.

Submenu	Meaning	Description
Slide test points	Test for engaging the various position points of the slider.	Checking the calibration
Slide	Driving the left and right metering slide	
Voltage	Checking the operating voltage.	page 70
Weighing cells	Check of actuators and sensors.	page 70
Drop point	Engaging the drop point.	
Empty message sensors	Check	
Telimat Sensor	Checking the Telimat Sensors.	page 70

1. Switch from the **System/Test** menu to the submenu **Test/Diagnosis**.
2. Highlight the desired function and press the enter key.
 - ▷ The display shows the status of the sensors or actuators.

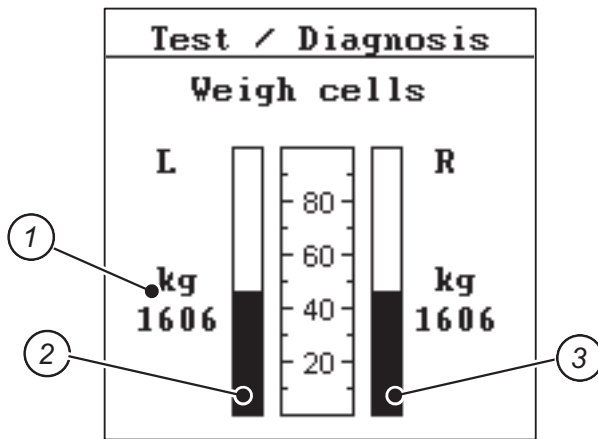

Figure 4.35:Test/Diagnosis;Example: Weighing cells

- [1] Current fertiliser volume in left hand hopper
- [2] Fill level left, in percent
- [3] Fill level right in percent

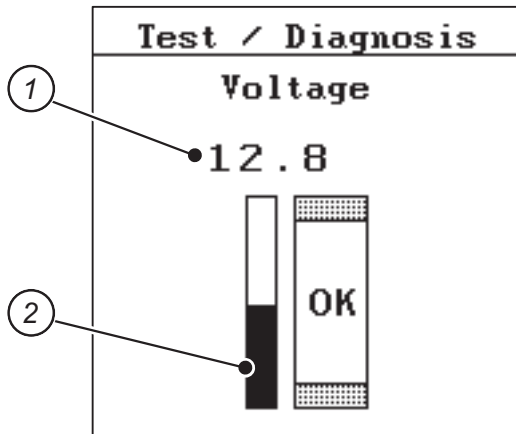

Figure 4.36:Test/Diagnosis; Example: Voltage

- [1] Current operating voltage
- [2] Functional range of the sensor

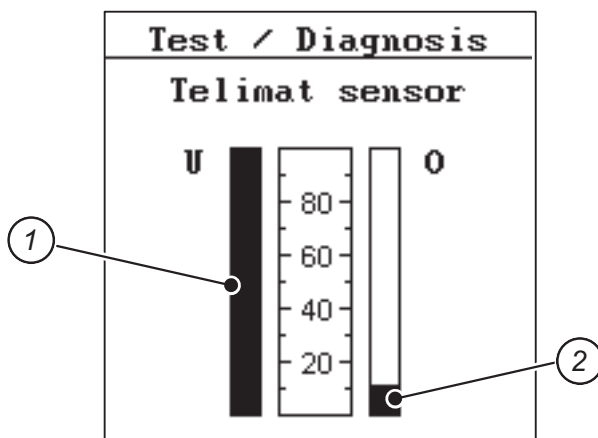

Figure 4.37:Test/Diagnosis; Example: Telimat Sensor

- [1] Lower position approached
- [2] Top position not approached

4.8.4 Data transmission

Data transmission takes place using various data protocols.

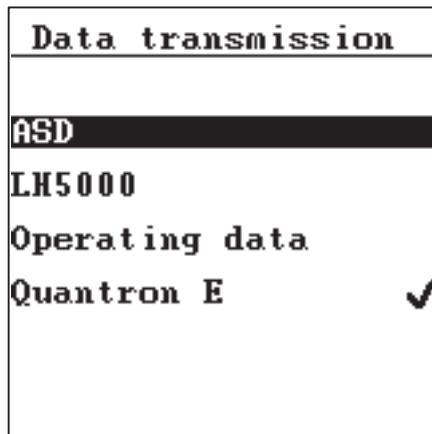

Figure 4.38: Data transmission menu

Submenu	Meaning	Description
ASD	Automatic field management documentation; Transmission of operating data to a PDA or Pocket PC via Bluetooth	
LH5000	Serial communication e.g. spreading using application cards	
Operating data	Importing/exporting up to 200 operating data files	See below
Quantron E	Transmission of the new software	

Importing operating data (PC to Quantron E)

Requirements:

- Use the data stick supplied.
 - Do not alter the directory structure on the data stick.
 - The data is stored on the data stick on the directory operating_data_Import.
1. Switch from the **System/Test** menu to the **Data transmission** submenu.
 2. Switch to the **Operating data** submenu.
 3. Highlight the **Import** field.

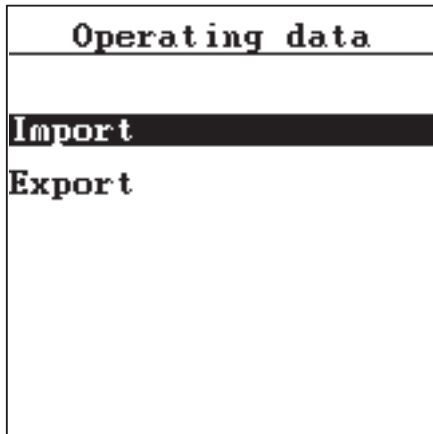

Figure 4.39:Importing and exporting operating data

4. Press the **Enter key**.
 - ▷ A message appears indicating that the current data will be deleted.

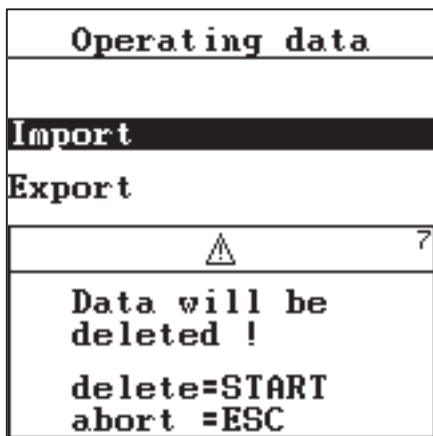

Figure 4.40:Message prior to deletion of the files

5. Press the **Start/Stop button**.
 - ▷ The bar indicates the progress of the transmission.

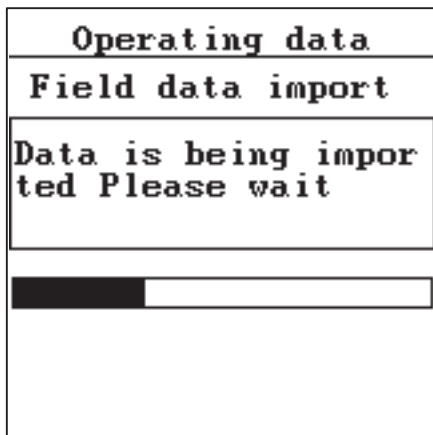

Figure 4.41:Import progress

The consequences of importing the operating data are as follows:

- All operating data currently stored in the Quantron E is overwritten.
- If you have defined the application rate on the PC, the application rate is automatically transferred and immediately activated in the fertiliser settings menu.
- If you enter an application rate outside the range 10-3000, the value in the fertiliser settings menu is not overwritten.

Exporting operating data (Quantron E to PC)**Requirements:**

- Use the data stick supplied.
 - Do not alter the directory structure on the data stick.
1. Switch from the **System/Test** menu to the **Data transmission** submenu.
 2. Switch to the **Operating data** submenu.
 3. Highlight the **Export** field.
 4. Press the **Enter** key.
- ▷ **The bar indicates the progress of the transmission.**

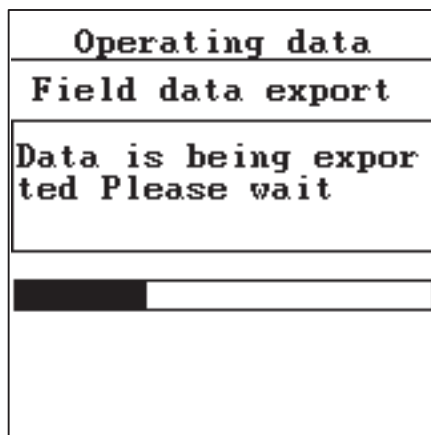
**Figure 4.42:** Export progress**The consequences of importing the operating data are as follows:**

- All operating data currently stored in the Quantron E is overwritten.
- If you have defined the application rate on the PC, the application rate is automatically transferred and immediately activated in the fertiliser settings menu.
- If you enter an application rate outside the range 10-3000, the value in the fertiliser settings menu is not overwritten.

4.8.5 Service

NOTICE

An input code is required for settings in the **Service** menu. These settings can only be modified by authorised service personnel.

As a general rule, we recommend that all settings in this menu are carried out by authorised service personnel.

4.9 Special functions

4.9.1 Text input

In some menus freely editable text can be input.

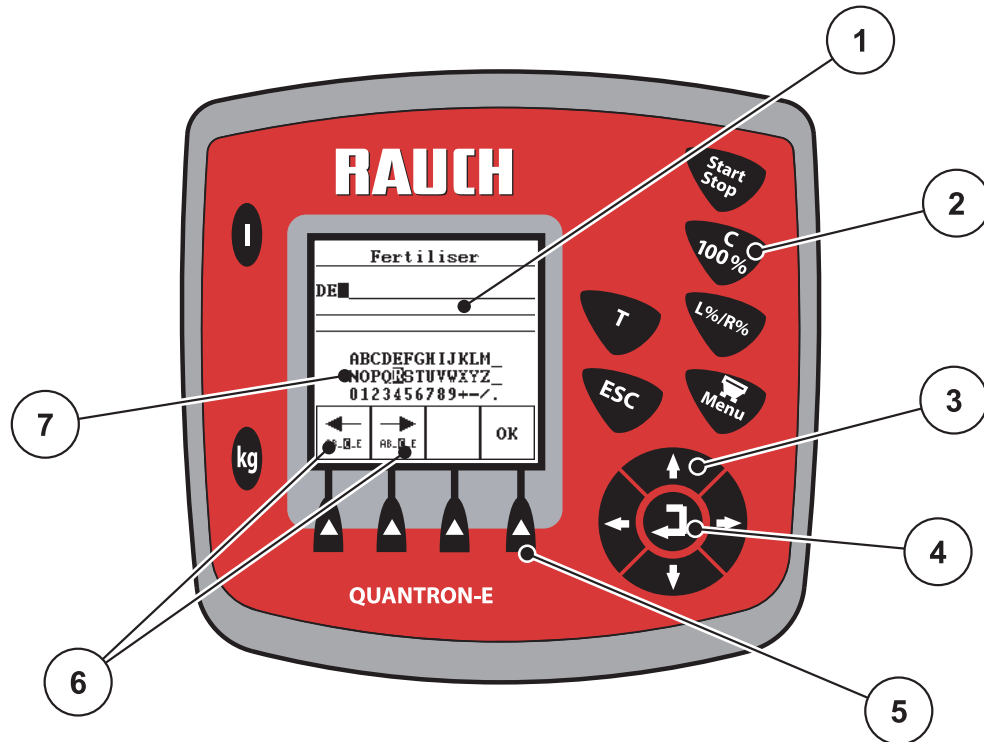

Figure 4.43: Text input menu

- [1] Input field
- [2] Delete the complete input
- [3] Arrow keys for navigation through the character field
- [4] Enter key to confirm input
- [5] Function key for terminating the input and return to the previous menu
- [6] Function keys for navigation in the input field
- [7] Character field, display of available characters (language-dependent)

Input text:

1. Switch from the higher level menu to the **Text input** menu.
2. Move the cursor by using the **arrow keys** to the position of the first letter to be written in the input field.
3. Highlight the character to be written in the character field using the **function keys**. Press the **Enter key**.
 - ▷ The highlighted character is input into the field. The cursor jumps to the next position.

Continue with this procedure until the entire text has been introduced.

4. To **terminate** the input press the **OK** function key.
 - ▷ The text is stored in the control unit.
 - ▷ The previous menu is displayed.

Overwrite character:

A single character can be overwritten by another character. A single character cannot be deleted.

5. Move the cursor by using the **arrow keys** to the position of the character to be deleted in the input field.
6. Replace the character by selecting the desired character in the character field.

Delete input:

The complete input can be deleted.

7. Press the **C/100%** key.
8. Confirm the selection by pressing the **Enter key**.
 - ▷ The complete input is deleted.

4.9.2 Input of values using the cursor keys

In some menus numerical values can be entered.

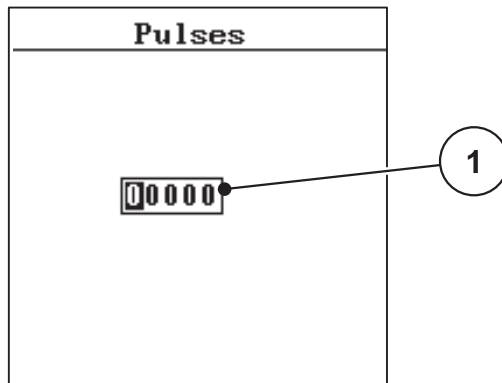

Figure 4.44: Numerical value entry (example of pulse input)

[1] Input field

You are already in the menu in which you make numerical inputs.

1. Move the cursor by using the horizontal **arrow keys** to the position of the numeric value to be written in the input field.
2. Set the desired numerical value by using the vertical arrow keys.
 - Arrow key up: numerical value increases.
 - Arrow key down: numerical value decreases.
3. Confirm the input by pressing the **Enter key**.

5 Alarm messages and possible causes

Various alarm messages can be displayed on the control unit Quantron E display.

5.1 Meaning of alarm messages

No.	Message in display	Meaning ● Possible cause
1	Error in the metering direction.	The actuator for the metering device cannot reach the set value to be moved to. ● Blockade ● No position message
2	Speed or appl. rate to high.	Metering slide alarm ● The maximum metering opening is reached. ● The set metering volume (+/- amount) exceeds the maximum metering opening.
3	Flow factor is outside the limits	The flow factor must be in the range 0.40 - 1.90 . ● The new calculated or entered flow factor is outside the range.
4	Left hopper empty!	The level sensor on the left reports "empty". ● Left-hand hopper is empty.
5	Right hopper empty!	The level sensor on the right reports "empty". ● Right-hand hopper is empty.
7	Data will be deleted! Delete = START Cancel = ESC	Safety alarm, to prevent the unintentional deletion of data.
8	Minimum spreading quantity 150 kg not achieved. Old factor valid.	Flow factor calculation not possible. ● Operating mode Auto km/h + Stat. kg is selected. ● The appl.rate is too low to calculate the new flow factor when the remnant is weighed. ● The old flow factor is retained.
9	Min.setting = 10 Max.setting = 3000	Reference to the value range of the application rate . ● Value entered is not permitted.

No.	Message in display	Meaning <ul style="list-style-type: none"> ● Possible cause
10	Min.setting = 2.00 Max.setting = 50.00	Reference to the range of values for the working width . <ul style="list-style-type: none"> ● Value entered is not permitted.
11	Min.setting = 0.40 Max.setting = 1.90	Reference to the value range of the flow factor . <ul style="list-style-type: none"> ● Value entered is not permitted.
12	Error during data transmission. No RS232 connection.	An error has occurred during data transmission to the control unit. The data have not been transmitted.
14	Error in Telimat device.	Alarm for the Telimat actuator. The actuator cannot reach the target value to be started. <ul style="list-style-type: none"> ● Blockade ● No position message
15	Memory is full. Deletion of a private table required	A maximum of 30 private tables can be saved. <ul style="list-style-type: none"> ● No additional saving possible
16	Move to drop point Yes = START	Only for AXIS 50.1 W: Safety request before automatic approach to the drop point. <ul style="list-style-type: none"> ● Setting the drop point in Fertiliser settings menu ● Fast emptying
17	Error in drop point setting	The actuator for the drop point setting cannot reach the set value to be moved to. <ul style="list-style-type: none"> ● Blockade ● No position message
21	Spreader overloaded	Only for weighing spreader: the fertiliser spreader is overloaded. <ul style="list-style-type: none"> ● Too much fertiliser in the hopper

5.2 Clear fault / alarm

5.2.1 Acknowledging alarm message:

An alarm message is highlighted in the display and displayed with a warning icon.

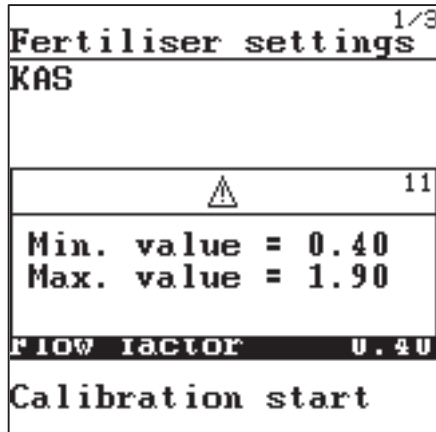

Figure 5.1: Alarm message (example: fertiliser settings)

Acknowledging alarm message:

1. Correct the cause of the alarm message.
Observe the operating manual of the fertiliser spreader and section [5.1: Meaning of alarm messages, page 77](#).
2. Press the **C/100%** key.
▷ **The alarm message is cleared.**

5.2.2 Resolving problems with the flow factor regulation (only AXIS W):

Under certain conditions, the display of the flow factor can freeze, despite having carried out the **Weigh Quantity** function. The following alarm message appears in the display.

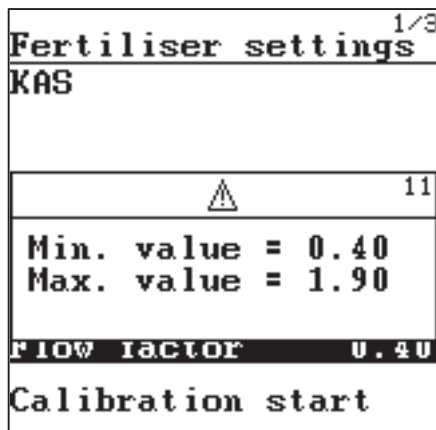

Figure 5.2: Flow factor error message

⚠ CAUTION



Possible spreading error





This alarm message can lead to spreading errors which have a negative impact on the environment.

► **Immediately stop** the spreading process.

Acknowledging alarm message:

1. Proceed as described in the previous paragraph.
2. Switch the control unit Quantron E off (**ON/OFF**) and then restart it.
3. Switch to the **Weigh Quantity** menu using the kg button.
4. Select the function **New fertiliser**.
5. Press the **Enter key**.
- ▷ **The flow factor is set to 1.0 and the remaining fertiliser volume in the hopper is weighed.**
6. Press the **ESC key** to return to the **previous menu**
or
Press the **Menu key** to return to the **Operating Screen**.
7. Switch to the **Operating Screen**.
 - ▷ The weighed volume appears on the display field.
 - ▷ The error is cleared and the spreading process can continue.
- ▷ **A new flow factor regulation process takes place.**

6 Special equipment/options

No.	Illustration	Name
1		Empty message sensor for AXIS
2		Ground speed sensor for Quantron E
3		Y cable RS232 for data exchange (e. g. GPS, N sensor, etc.)
4		System tractor cable set for Quantron E AXIS 12 m AXIS W 12 m

6 Special equipment/options

No.	Illustration	Name
5		GSP cable and receiver
6		Telimat Sensor
7		Suction cup bracket for Quantron E

7 Guarantee and warranty

Rauch units are manufactured with modern production methods and with the greatest care and are subject to numerous inspections.

Therefore RAUCH offers a 12-month warranty subject to the following conditions:

- The warranty begins on the date of purchase.
- The warranty covers material and manufacturing faults. Our liability for third-party products (hydraulic system, electronics) is limited to the warranty of the manufacturer of the equipment. During the warranty period, manufacturing and material faults are corrected free of charge by replacement or repair of the affected parts. Other rights extending beyond the above, such as claims for conversion, reduction or replacement for damages that did not occur in the object of supply are explicitly excluded. Warranty services are provided by authorised workshops, by RAUCH factory representatives or the factory.
- The guarantee excludes the consequences of natural wear, contamination with dirt, corrosion and all faults caused by inappropriate handling and external influences. The warranty is rendered void if the owner carries out repairs or modifications to the original state of the object of supply. Warranty claims are rendered void if RAUCH original spare parts were not used. Please follow the directions in the operator's manual. In all cases of doubt, contact our factory representatives or the factory directly. Warranty claims must be submitted to the factory by 30 days at the latest after occurrence of the problem. The date of purchase and the serial number are required. If repairs under the warranty are required, they must be carried out by the authorised workshop only after consultation with RAUCH or the company's appointed representatives. The warranty period is not extended by work carried out under warranty. Shipping faults are not factory faults and therefore are not part of the warranty obligation of the manufacturer.
- No claims for compensation for damages that are not part of the fertiliser spreader itself will be accepted. This also means that no liability will be accepted for damages resulting from spreading errors. Unauthorised modifications to the RAUCH devices can lead to consequential damage for which the supplier accepts no liability. The supplier's exclusion of liability is not applicable in the event of the owner's or an executive employee's intent or gross negligence and in cases where, in accordance with the product liability law, defects in the object of supply incur personal or material damage to privately used objects and liability is accepted. It will also not apply in the case of faults in properties that are explicitly assured, if the assurance had the purpose of protecting the purchaser against damage that does not arise from the object of supply itself.