

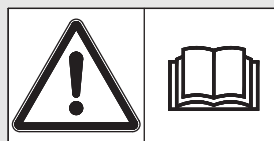

**RAUCH**  
wir nehmen's genau

# INSTRUCTION MANUAL

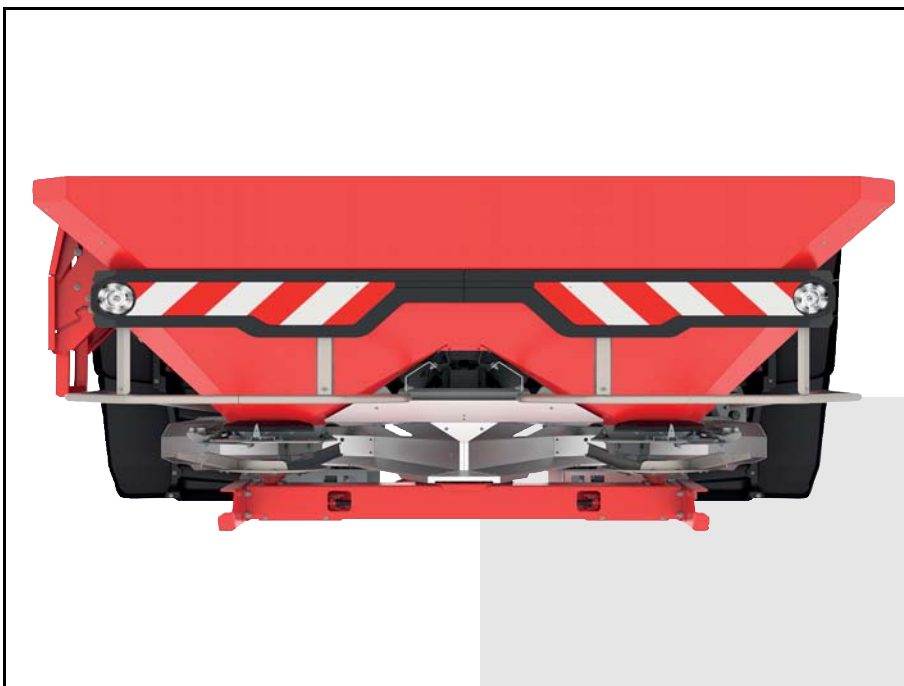

**Please read carefully  
before using the ma-  
chine.**

Keep for future reference.

This instruction manual/assembly instruction is to be considered as part of the machine. Suppliers of new and second-hand machines are required to document in writing that the instruction manual/assembly instruction was delivered with the machine and handed over to the customer.

# AXIS-M 50.2

Original manual

5902385-a-en-1217

## Preface

Dear Customer

By purchasing the mineral fertiliser spreader of the AXIS series you have shown confidence in our product. Thank you very much! We want to justify this confidence. You have purchased a powerful and reliable machine.

However, in case unexpected problems arise: Our customer service is always there for you.

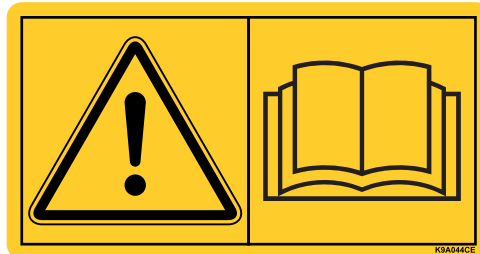

**Please read this operator's manual carefully before commissioning the mineral fertiliser spreader and follow the advice given.**

This operator's manual gives detailed instructions on the operation of the machine, as well as valuable information on assembly, maintenance, and care.

This manual may also describe equipment that is not included in your machine.

Please note that damage caused by incorrect operation or improper use may not be covered by warranty claims.

### NOTICE

We kindly ask you to enter the type and serial number as well as the year of construction of your mineral fertiliser spreader here.

These data are provided on the machine nameplate or on the frame.

Please state this information when ordering spare parts or accessories, and in case of complaints.

Type:

Serial number:

Year of manufacture:

### Technical improvements

**We are continuously improving our products. Therefore, we reserve the right to make any improvements and changes to our machine that we consider necessary without notice. This constitutes no obligation to make such improvements or changes on machines that have already been sold.**

We will be pleased to answer any other questions that you might have.

Yours sincerely

RAUCH

Landmaschinenfabrik GmbH

## Preface

Technical improvements

<b>1</b>	<b>Intended use</b>	<b>1</b>
<b>2</b>	<b>User instructions</b>	<b>3</b>
2.1	About this operator's manual . . . . .	3
2.2	Structure of the operator's manual . . . . .	3
2.3	Notes on text descriptions . . . . .	4
2.3.1	Instructions and procedures . . . . .	4
2.3.2	Listings . . . . .	4
2.3.3	References . . . . .	4
<b>3</b>	<b>Safety</b>	<b>5</b>
3.1	General Information . . . . .	5
3.2	Significance of warnings . . . . .	5
3.3	General information on the safety of the machine . . . . .	7
3.4	Instructions for the operator . . . . .	7
3.4.1	Personnel qualifications . . . . .	7
3.4.2	Instruction . . . . .	7
3.4.3	Accident prevention . . . . .	8
3.5	Information on operational safety . . . . .	8
3.5.1	Parking the machine . . . . .	8
3.5.2	Filling the machine . . . . .	8
3.5.3	Checks before start-up . . . . .	9
3.5.4	Hazard zone . . . . .	9
3.5.5	Operation . . . . .	10
3.6	Use of fertiliser . . . . .	10
3.7	Hydraulic system . . . . .	10
3.8	Maintenance and repair . . . . .	11
3.8.1	Qualifications of maintenance staff . . . . .	11
3.8.2	Wear parts . . . . .	11
3.8.3	Maintenance and service work . . . . .	12
3.9	Safety in traffic . . . . .	13
3.9.1	Checks before driving . . . . .	13
3.9.2	Transportation drive with the machine . . . . .	13
3.10	Safety equipment at the machine . . . . .	14
3.10.1	Position of safety equipment . . . . .	14
3.10.2	Function of safety equipment . . . . .	16
3.11	Warning and instruction stickers . . . . .	17
3.11.1	Warning stickers . . . . .	18
3.11.2	Instruction stickers and nameplate . . . . .	19
3.12	Homologation sign . . . . .	20
3.13	Reflector . . . . .	20

<b>4</b>	<b>Technical data</b>	<b>21</b>
4.1	Hersteller	21
4.2	Description of the machine.	21
4.2.1	Assembly overview.	22
4.2.2	Transmission for the M EMC function.	24
4.2.3	Agitator	24
4.3	Machine data	25
4.3.1	Versions	25
4.3.2	Technical data of basic equipment.	26
4.3.3	Technical data of the extensions	27
4.4	List of available accessories.	28
4.4.1	Extensions	28
4.4.2	Hopper cover	28
4.4.3	Electrical remote control of the hopper cover AP drive	28
4.4.4	Tele-Space universal drive shaft	28
4.4.5	Auxiliary lighting	29
4.4.6	Stabilising rollers with bracket ASR 25.	29
4.4.7	Limited border spreading unit GSE 60	29
4.4.8	Hydraulic remote control FHD 30-60 for GSE 60	29
4.4.9	Spreader vane set Z14, Z16, Z18.	30
4.4.10	Practice test kit PPS5.	30
4.4.11	Fertiliser identification system DIS	30
4.4.12	Fertiliser chart booklet	30
4.4.13	SpreadLight operating lights.	30
<b>5</b>	<b>Axle load calculation</b>	<b>31</b>
<b>6</b>	<b>Transportation without tractor</b>	<b>35</b>
6.1	General safety instructions.	35
6.2	Loading and unloading, parking.	35
<b>7</b>	<b>Commissioning</b>	<b>37</b>
7.1	Accepting the machine.	37
7.2	Requirements for the tractor.	38
7.3	Mounting the universal drive shaft at the machine.	38
7.4	Installing the machine on the tractor	42
7.4.1	Requirements	42
7.4.2	Attachment	43
7.5	Connecting the metering slide actuator	46
7.5.1	Connecting the hydraulic slide actuators: Version D	46
7.5.2	Connecting the electronic slide actuator: Version W	46
7.6	Presetting the mounting height.	47
7.6.1	Safety	47
7.6.2	Maximum admissible mounting height at front (V) and rear (H)	48
7.6.3	Mounting heights A and B according to fertiliser chart	49
7.7	Filling the machine	53
7.8	Using the fertiliser chart	54
7.8.1	Information on the fertiliser chart	54
7.8.2	Settings as per fertiliser chart.	54

---

7.9	Setting the GSE limited border spreading unit optional equipment . . . . .	61
7.10	Adjustment of standard equipment TELIMAT . . . . .	63
7.10.1	Setting the TELIMAT . . . . .	63
7.10.2	Correcting the spreading distance . . . . .	65
7.10.3	Instructions for spreading with TELIMAT . . . . .	65
7.11	Settings for unlisted fertiliser types . . . . .	67
7.11.1	Requirements and conditions. . . . .	67
7.11.2	Running one passage . . . . .	68
7.11.3	Running three passages . . . . .	69
7.11.4	Evaluate the results and correct if necessary . . . . .	70
<b>8</b>	<b>Spreading operation</b>	<b>73</b>
8.1	Safety. . . . .	73
8.2	Instructions regarding the spreading operation . . . . .	74
8.3	Using the fertiliser chart. . . . .	75
8.4	Adjusting the application rate. . . . .	75
8.4.1	Version W/EMC (+ W) . . . . .	75
8.4.2	Version D . . . . .	76
8.5	Setting the working width. . . . .	77
8.5.1	Selecting the correct spreading disc . . . . .	77
8.5.2	Removing and mounting spreading discs . . . . .	78
8.5.3	Adjusting the drop point . . . . .	80
8.6	Checking the mounting height. . . . .	82
8.7	Setting the PTO speed . . . . .	82
8.8	Spreading at the headlands. . . . .	83
8.9	Spreading with section control (VariSpread) . . . . .	85
8.10	Calibration . . . . .	87
8.10.1	Determining the nominal output quantity . . . . .	87
8.10.2	Implementing the calibration . . . . .	90
8.11	Discharging residual material . . . . .	95
8.12	Parking and decoupling the machine. . . . .	96
<b>9</b>	<b>Faults and possible causes</b>	<b>97</b>

<b>10 Maintenance and service</b>	<b>101</b>
10.1 Safety	101
10.2 Using the steps	102
10.2.1 Safety	102
10.2.2 Folding out the steps	102
10.2.3 Folding in the steps	103
10.2.4 Using the steps securely	104
10.3 Wear parts and screw connections	105
10.3.1 Checking wear-prone parts	105
10.3.2 Checking screw connections	105
10.3.3 Checking the screw connections of the weigh cells (version W)	106
10.4 Maintenance plan	108
10.5 Opening the protective grid in the hopper	109
10.6 Cleaning	111
10.6.1 Disassemble the dirt deflector	111
10.6.2 Dismounting the dirt deflector	112
10.7 Checking the position of the spreading disc hub	112
10.8 Checking the agitator drive	113
10.9 Spreader vane replacement	115
10.10 Metering slide adjustment	117
10.11 Checking the drop point	121
10.11.1 Checking AXIS 50.2 D:	123
10.11.2 Adjusting AXIS 50.2 D:	124
10.11.3 Checking AXIS 50.2 W:	125
10.11.4 Checking AXIS 50.2 W:	126
10.12 Transmission oil (not for EMC machines)	127
10.12.1 Quantity and types	127
10.12.2 Checking the oil level, changing the oil	127
10.13 Lubrication plan	130
<b>11 Disposal</b>	<b>131</b>
11.1 Safety	131
11.2 Disposal	132
<b>Index</b>	<b>A</b>

**Terms/conditions of warranty**

## 1 Intended use

The mineral fertiliser spreaders of the AXIS series may only be used in accordance with the stipulations of the present operator's manual.

The mineral fertiliser spreaders of the AXIS series are constructed in accordance with their intended use.

**They may only be used for the application of dry, granular and crystalline fertilisers, seeds and slug pellets.**

Any use beyond these specifications is considered as contrary to the intended use. The manufacturer shall not assume any liability for any damages resulting in this respect. The risk is solely carried by the operator.

The intended use also comprises the compliance with the operating, maintenance and repair conditions prescribed by the manufacturer. Only genuine spare parts from the manufacturer may be used as replacements.

The mineral fertiliser spreaders of the AXIS series may only be used, maintained and repaired by people who are familiar with the characteristics of the machine and who are aware of the risks.

The instructions regarding the operation, service and safe handling of the machine as described in this operator's manual and declared by the manufacturer in the form of warning signs and symbols on the machine must be strictly followed during operation.

Moreover, the relevant accident prevention regulations and the other generally recognised safety, occupational health, and road traffic regulations must be strictly observed when using the machine.

Any unauthorized modifications to the mineral fertiliser spreaders of the AXIS series are inadmissible. Such modifications exclude any liability of the manufacturer for any resulting damages.

In the following chapters, the mineral fertiliser spreader is referred to as "**machine**".

### **Foreseeable misuse**

With the warning notes and pictorial warnings attached to the mineral fertiliser spreader of the AXIS series, the manufacturer points out foreseeable misuse. These warnings and warning symbols must always be observed. This way, you can prevent the application of the mineral fertiliser spreader of the AXIS series against the intentions of the operator's manual.





## 2 User instructions

### 2.1 About this operator's manual

This operator's manual is an **integral part** of the machine.

The operator's manual contains important information for a **safe, appropriate** and economic **use** and **maintenance** of the machine. Adherence to this operator's manual helps to **avoid risks**, to reduce repair costs and downtime, and to increase the machine's reliability and service life.

The complete documentation, comprising this operator's manual and any other documents provided, must be kept in an easily accessible location close to where the machine is used (e.g. in the tractor).

If the machine is sold, the operator's manual must also be passed to the new owner.

The operator's manual is intended for the operator of the machine and anyone involved in operating and maintaining it. It must be read, understood, and applied by all persons entrusted with the following work on the machine:

- Operation,
- Maintenance and cleaning,
- Repairing faults.

In particular, the following is to be observed:

- The chapter on safety,
- The warning instructions in the text of the individual chapters.

The **operator's manual does not replace** your **own responsibility** as the operator and operating personnel of the control unit.

### 2.2 Structure of the operator's manual

The operator's manual is divided into six key areas in terms of content:

- User instructions
- Safety instructions
- Machine data
- Instructions on the operation of the machine,
  - Transportation
  - Commissioning
  - Spreading operation
- Instructions on detecting and rectifying faults
- Maintenance and repair instructions

### 2.3 Notes on text descriptions

#### 2.3.1 Instructions and procedures

Steps that the operator must carry out are shown as a numbered list.

1. Instruction for action step 1
2. Instruction for action step 2

Instructions involving only one step are not numbered. The same applies for action steps that do not have a specific sequence.

A bullet is placed in front of these instructions:

- Handling instruction

#### 2.3.2 Listings

Listings without a specific sequence are shown with bullet points (level 1) and dashes (level 2):

- Property A
  - Point A
  - Point B
- Property B

#### 2.3.3 References

References to other text passages in the document are indicated with section number, headline text and page number:

- **Example:** See also Chapter [3: Safety, page 5](#).

References to other documents are indicated as note or instruction without exact chapter or page number:

- **Example:** Please also observe the instructions contained in the manual for the universal drive shaft.

### 3 Safety

#### 3.1 General Information

The chapter **Safety** contains basic warning notes as well as working and traffic safety instructions for the usage of the installed machine.

The adherence to the instructions in this chapter is a prerequisite for the safe handling and trouble-free operation of the machine.

There are additional warnings in the other chapters of this operator's manual, which must also be observed. The warning instructions are given before the text for the relevant actions.

Warning notes on the supplier components can be found in the respective supplier documentation. These warning instructions must also be observed.

#### 3.2 Significance of warnings

The warning instructions in this manual have been structured according to the degree of danger and the probability of their occurrence.

Danger signs and symbols inform the user about other construction-related and unavoidable residual risks that may be encountered when operating the machine. The warning notes used are structured as follows:

<b>Signal word</b>	
Symbol	Explanation

#### Example

<b>▲ DANGER</b>	
	<p><b>Risk to life if warning is not observed</b></p> <p>Description of the danger and possible consequences.</p> <p>Ignoring these warnings will result in very serious or even fatal injury.</p> <p>▶ Measures to prevent the danger.</p>

### Warning severity level

The degree of danger is indicated by the signal word. The levels are classified as follows:

#### ▲ DANGER



##### Type and source of danger

This warning warns of a danger posing an immediate threat to the health and life of persons.

Ignoring these warnings will result in very serious or even fatal injury.

- ▶ Always observe the measures described to prevent this danger.

---

#### ▲ WARNING



##### Type and source of danger

This warning warns of a possible dangerous situation for the health of persons.

Ignoring these warnings will result in very serious injury.

- ▶ Always observe the measures described to prevent this danger.

---

#### ▲ CAUTION



##### Type and source of danger

This warning warns of a potentially dangerous situation for personal health or of material and environmental damage.

Ignoring this warning can result in injuries and damage to the product or the general area.

- ▶ Always observe the measures described to prevent this danger.

---

#### NOTICE

General information containing application tips and particularly useful information, but which constitutes neither warnings nor hazards.

---

### 3.3 General information on the safety of the machine

The machine is constructed in accordance with the state of the art and the recognized technical regulations. However, its usage and maintenance may cause danger to the health and life of the operator or third parties and/or the impairment of the machine and other material assets.

For this reason, the machine may only be operated

- when it is in a proper and roadworthy condition,
- in awareness of safety and dangers.

Therefore, it is imperative that you have read and understood the contents of the operator's manual. You must be familiar with the applicable accident protection regulations and the generally accepted regulations for safety, occupational health, and road traffic, and apply these rules as required.

### 3.4 Instructions for the operator

It is the operator's responsibility that the machine is used as intended.

#### 3.4.1 Personnel qualifications

Before starting any work on or with the machine, all persons who are involved in operation, maintenance or service must have read and understood this operator's manual.

- The machine may only be operated by instructed personnel authorized by the owner.
- Persons who are apprentices, in training or under instruction may only work on the machine under the supervision of an experienced person.
- Only qualified maintenance staff may implement maintenance and service work.

#### 3.4.2 Instruction

Distribution partners, works representatives or employees of the manufacturer will instruct the operator regarding the operation and maintenance of the machine.

The owner must ensure that newly recruited operating and maintenance personnel are instructed to the same extent and with the same care with regard to the operation and repair of the machine in compliance with this operator's manual.

### 3.4.3 Accident prevention

Safety and accident prevention regulations are governed by law in every country. The operator of the machine shall be responsible for the compliance with these regulations applicable in the country of use.

The following instructions must also be observed:

- Never let the machine run without supervision.
- Do not ride on the machine while it is working or being transported (**no passengers**).
- Do **not** use machine parts as steps.
- Always wear tight fitting clothes. Do not wear work clothes with belts, loose threads or other items that could snag.
- Follow the manufacturer's warning notes when handling chemicals. You may have to wear personal protective equipment (PPE).

### 3.5 Information on operational safety

Only use the machine in an operational safe state. Avoid hazardous situations.

#### 3.5.1 Parking the machine

- Only park the machine with the hopper empty and on horizontal, solid ground.
- If the machine is parked alone (without tractor), open the metering slides completely. The return springs of the single-acting slide actuation are released.

#### 3.5.2 Filling the machine

- Only fill the machine when the motor of the tractor is stopped. Remove the ignition key in order to ensure that the motor cannot be started.
- Use suitable auxiliary equipment for filling the machine (e.g. front-end loader, feed screw conveyor).
- Fill the machine no higher than the top-edge. Check the fill level, e.g. through the viewing window in the hopper (depending on the model).
- Only fill the machine with the protective grid closed. This way, faults during spreading caused by lumps in the spreading material or other foreign bodies are prevented.

### 3.5.3 Checks before start-up

Check the operating safety of the machine before the first and every subsequent commissioning.

- Are all safety devices at the machine installed and functioning?
- Are all fasteners and load-bearing connections tightly installed and in good condition?
- Are the spreading disks and their fixings in good condition?
- Are the protective grids in the hopper closed and locked?
- Is the test dimension of the protective grid lock within the proper range? See [Figure 10.10](#) on [Page 110](#).
- Is the hazard zone of the machine **clear** of persons?
- Is the drive shaft cover in good condition?

### 3.5.4 Hazard zone

Flying spreading material may cause serious injury (e.g. to the eyes).

When persons are present between the tractor and the machine, there is a great hazard caused by the tractor rolling away or machine movements which may have fatal consequences.

The following figure displays the hazard zones of the machine.

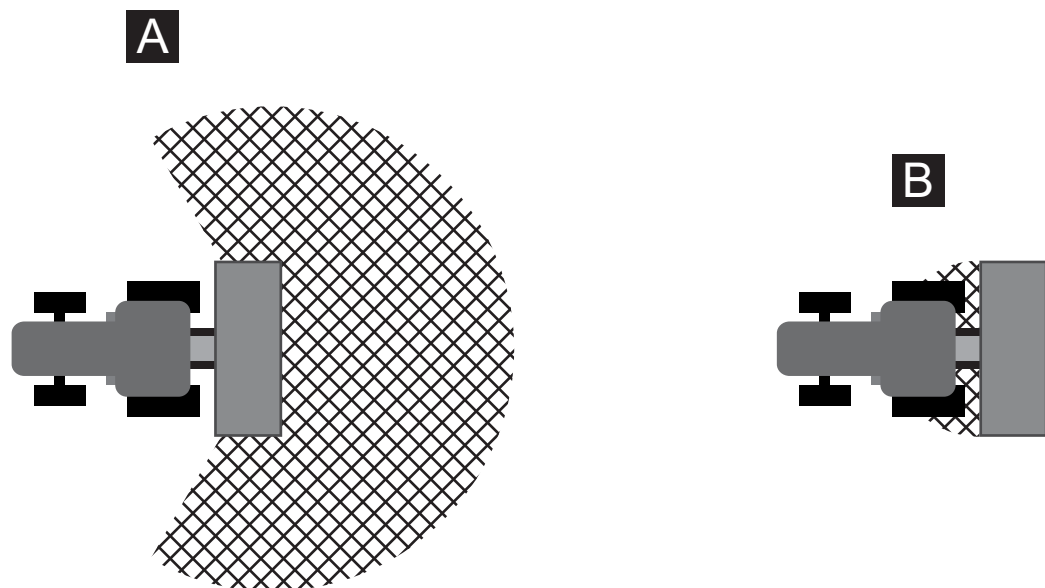

**Figure 3.1:** Hazard zones around attachment units

- [A] Hazard zone in spreading operation  
 [B] Hazard zone when coupling/de-coupling the machine

- Ensure that no persons are present in the spreading range [A] of the machine.
- Immediately stop the machine and the tractor if persons are present in the hazard zone of the machine.
- When actuating the hydraulic lift, ensure that nobody is present in the hazard zone [B].

### 3.5.5 Operation

- If the machine malfunctions, stop the machine immediately and secure it. Have the fault repaired immediately by qualified technicians.
- Never climb onto the machine while the spreader unit is running.
- Only operate the machine with the protective grid in the hopper closed. During operation, the protective grid **must neither be opened nor removed**.
- Rotating machine components can cause serious injury. For this reason, ensure that you avoid any contact between body parts or clothes and rotating components.
- Do not deposit any external parts (such as screws, nuts) in the spreader hopper.
- Ejected spreader material may cause serious injury (e.g. to the eyes). For this reason, ensure that nobody is present in the spreading area of the machine.
- If the wind speed is too high, stop the spreading operation because the specified spreading range cannot be guaranteed under such conditions.
- Never climb onto the machine or the tractor when it is situated beneath high-voltage electrical power lines.

### 3.6 Use of fertiliser

An inappropriate selection or usage of the fertiliser may lead to severe personal injury or environmental damages.

- When selecting the fertiliser, inform yourself about its effects on persons, the environment, and the machine.
- Please follow the instructions of the fertiliser manufacturer exactly.

### 3.7 Hydraulic system

The hydraulic system is under high pressure.

Fluid escaping under high pressure can cause serious injuries and environmental damage. The following instructions must be observed to prevent danger:

- Always operate the machine below the permissible maximum operating pressure.
- Depressurise the hydraulic system **before** any **maintenance work**. Turn the tractor motor off. Secure it against reactivation.
- When looking for leaks, wear **protective glasses** and **protective gloves at all times**.
- In the case of injury in connection with hydraulic oil, **consult a physician immediately** as severe infections may occur otherwise.
- When connecting the hydraulic hoses to the tractor, ensure that the hydraulic system is **depressurised**, both on the tractor and the machine side.
- Attach the hydraulic hoses of the tractor and the spreader hydraulic systems only with the prescribed connections.
- Prevent any contamination of the hydraulic circuit. Always suspend the couplings in the brackets provided. Use the dust caps. Clean the connections before joining them.



- Regularly check the hydraulic components and hydraulic hose lines for mechanical defects, e.g. cuts and abrasions, contusions, bends, tears, porosity etc.
- Even when stored correctly and used within approved load limits, hoses and hose couplings are subject to a natural ageing process. This limits their storage and service life.

The service life of the hose lines may not exceed 6 years, including a possible storage time of maximally 2 years.

The date of manufacture of the hoses is indicated on the hose coupling in month and year

- Replace hydraulic hoses if damaged or aged.
- Replacement of hydraulic hoses must meet the technical requirements of the equipment manufacturer. In particular, note the different maximum pressure ratings of replacement hoses.

### **3.8 Maintenance and repair**

Maintenance and service work involves additional hazards that do not occur during operation of the machine.

- Any maintenance and service work is to be conducted with increased alertness at all times. Work particularly thoroughly and cautiously.

#### **3.8.1 Qualifications of maintenance staff**

- Welding and work on the electrical and hydraulic systems is to be carried out by qualified technicians only.

#### **3.8.2 Wear parts**

- The maintenance and service intervals described in the present operator's manual are to be strictly adhered to at all times.
- Furthermore, the maintenance and repair intervals of the supplier components must also be complied with. See the supplier documentation for the relevant intervals.
- We recommend that you have the condition of the machine checked after each season by your specialist dealer, paying particular attention to its fixing components, safety-relevant plastic components, hydraulic system, metering parts and spreader vanes.
- Spare parts must at least comply with the technical standards specified by the manufacturer. The technical standards can be guaranteed by using genuine spare parts.
- Self-locking nuts are designed to be used only once. Always use new self-locking nuts to fasten components (e.g. when replacing spreading vanes).

### 3.8.3 Maintenance and service work

- **Always switch off the tractor engine** before all cleaning, maintenance and service work and when troubleshooting. **Wait until all rotating parts of the machine have come to a standstill.**
- Make sure that **no unauthorised person** can start the machine. Remove the ignition key of the tractor.
- Before any maintenance and service work, separate the current supply between tractor and machine.
- Disconnect the power supply before working on the electrical system.
- Check that the tractor with the machine is correctly parked. Park the spreader with an empty hopper on level, solid ground and secure it to prevent it from moving.
- Before carrying out any maintenance and service work, depressurise the hydraulic system.
- If you must work while the PTO shaft is rotating, make sure that nobody is near the PTO or the universal drive shaft.
- Never remove any clogging in the spreader hopper with your hand or foot, but use suitable tools for this purpose. In order to avoid clogging, only fill the hopper when the protective grid is mounted.
- Before cleaning the machine with water, steam or other cleaning agents, cover all components that must not get wet (e.g. bearings, electrical connections).
- Regularly check nuts and screws for their tight seat. Retighten loose connections.

### 3.9 Safety in traffic

When driving on public streets and roads, the tractor with the attached machine must comply with the road traffic regulations of the respective country. The owner and driver are responsible for compliance with these regulations.

#### 3.9.1 Checks before driving

The pre-departure check is an important contribution to road safety. Before every trip, check compliance with the operating conditions, traffic safety, and the regulations of the country of operation.

- Is the permissible total weight complied with? Note the permitted axle load, the permitted braking load, and the permitted tyre load capacity; [See also "Axle load calculation" on page 31.](#)
- Is the machine attached appropriately?
- Could fertiliser be lost while travelling?
  - Check the level of the fertiliser in the hopper.
  - The metering slides must be closed.
  - The ball valves must also be closed on single-acting hydraulic cylinders.
  - Switch off the electronic control unit.
- Check the tyre pressures and the function of the tractor brake system.
- Does the lighting and marking of the machine comply with the regulations of your country with respect to driving on public roads? Make sure to make the fittings according to the regulations.

#### 3.9.2 Transportation drive with the machine

Handling, steering, and braking performance of the tractor are affected by the attached machine. For example, an excessive weight of the machine will reduce the weight on the tractor's front axle and affect its steering.

- Be aware of the changed driving behaviour.
- When driving, always ensure that there is sufficient visibility. If vision is restricted (e.g. when reversing), another person is required to direct the driver.
- Observe the permissible maximum speed.
- Avoid sudden turns when driving uphill or downhill or across a slope. Due to the changed centre of gravity, there is a danger of overturning. Special care is to be particularly applied when driving on uneven, soft ground (e.g. when entering fields, kerbs).
- Arrest sideways movement of the lower link of the three-point linkage to prevent the machine from swinging.
- Passengers are prohibited on the machine during the drive and operation.

### 3.10 Safety equipment at the machine

#### 3.10.1 Position of safety equipment

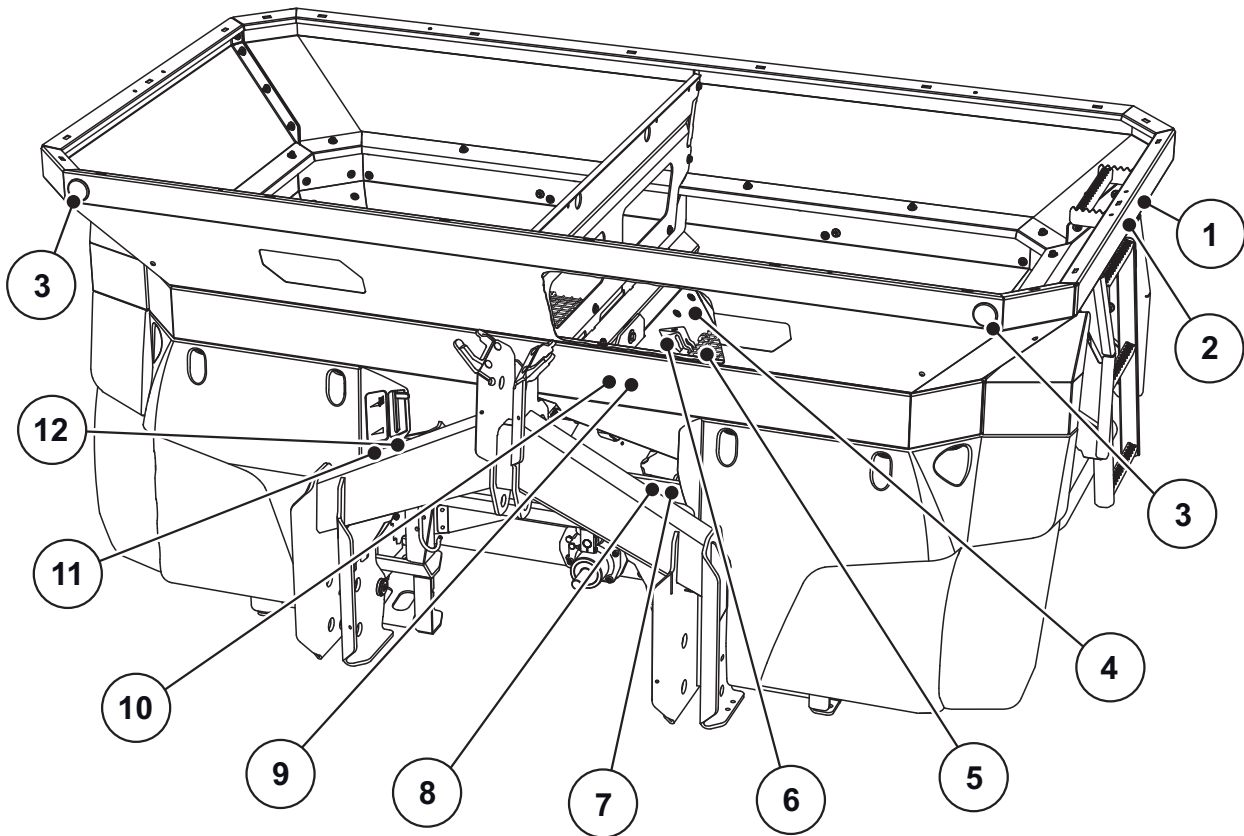

**Figure 3.2:** Safety equipment, warning and instruction stickers, front

- [1] Warning: passenger transport prohibited
- [2] Instructions: steps
- [3] White reflectors in front
- [4] Instructions: protective grid lock
- [5] Protective grid in hopper
- [6] Protective grid lock
- [7] Instructions: PTO speed
- [8] Instructions: maximum payload
- [9] Warning: ejection of material
- [10] Warning: read operator's manual
- [11] Homologation sign
- [12] Nameplate

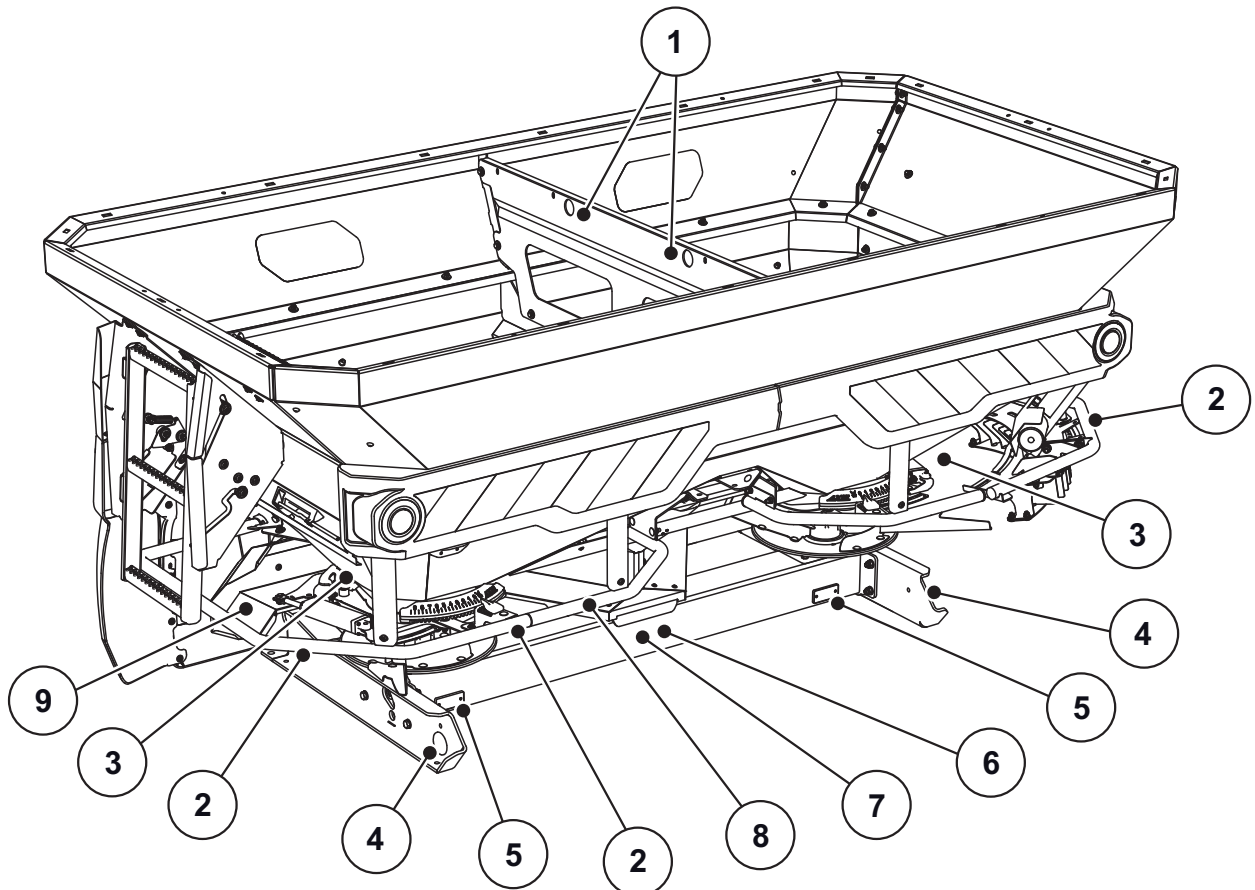

**Figure 3.3:** Safety equipment, warning and instruction stickers, rear

- [1] Instructions: ring eyelet in hopper
- [2] Deflector bracket
- [3] Danger of crushing
- [4] Yellow side reflectors
- [5] Red reflectors
- [6] Warning: remove ignition key
- [7] Warning: moving parts
- [8] Instructions: no climbing
- [9] Spreading disc cover

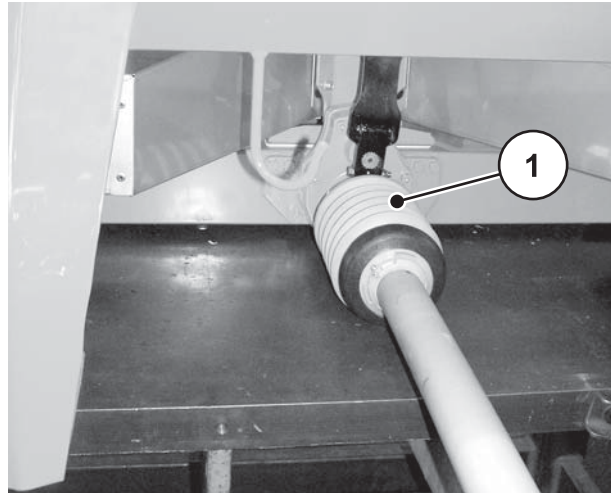

[1] Drive shaft guard

**Figure 3.4:** Drive shaft

### 3.10.2 Function of safety equipment

The safety equipment is designed to protect your health and life.

- Before working with the machine, ensure that the safety equipment is functional.
- Only operate the machine when the safety equipment is functional.
- Do **not** use the deflector bracket to climb up on the machine. It is not designed for this. There is a risk of falling.

Designation	Function
Protective grid in hopper	Prevents body parts from being caught by the rotating agitator. Prevents body parts from being cut off by the metering slider. Prevents faults during spreading caused by lumps in the spreading material, large stones or other large objects (screening effect).
Protective grid lock	Prevents the inadvertent opening of the protective grid in the hopper. Engages mechanically if protective grid is closed properly. Can only be opened by using a tool.
Deflector bracket	Protection against getting caught by the rotating spreading discs from behind and from the side.
Spreading disc cover	Protection against getting caught by the rotating discs from the front. Prevents the fertiliser from being ejected towards the front (in the direction of the tractor/workstation).
Drive shaft guard	Prevents body parts and clothing from being pulled into the rotating drive shaft.

### 3.11 Warning and instruction stickers

Various warning and instruction notes are attached to the machine (for the position at the machine, please refer to [3.10: Safety equipment at the machine, page 14](#)).

The warning and instruction stickers are components of the machine. They must not be removed or modified. Missing or illegible warning and instruction stickers must be replaced immediately.

If new components are installed during repairs, the same warning and instruction stickers that were on the original parts must be placed on the new parts.

---

**NOTICE**

The correct warning and instruction notices can be obtained from the spare parts service.





---

3.11.1 Warning stickers

	<p>Read the operator's manual and warnings.</p> <p>Read and observe the operator's manual and warning messages before commissioning the machine.</p> <p>The operator's manual explains in detail how to operate the spreader and contains valuable information on operation, care and maintenance.</p>
	<p>Danger due to ejection of material</p> <p>Danger of injury to the whole body caused by ejected spreading material</p> <p>Before commissioning, instruct all people to leave the hazard zone (spreading range) of the machine.</p>
	<p>Danger due to moving parts</p> <p>Risk of body parts being cut off</p> <p>It is prohibited to reach into the danger area of the rotating spreading discs, the agitator or the drive shaft.</p> <p>Switch off the engine and remove the key before carrying out maintenance, repair and adjustment work.</p>
	<p>Danger of crushing due to moving parts</p> <p>Risk of body parts being cut off</p> <p>It is prohibited to reach into the hazard zone of the metering slide.</p> <p>Switch off the engine and remove the key before carrying out maintenance, repair and adjustment work.</p>
	<p>Remove the ignition key.</p> <p>Before carrying out any repair and maintenance work, shut off the engine and remove the ignition key. Disconnect the power supply</p>
	<p>Taking passenger prohibited</p> <p>Risk of slipping and injury. Do not climb on the machine during spreading and transport.</p>

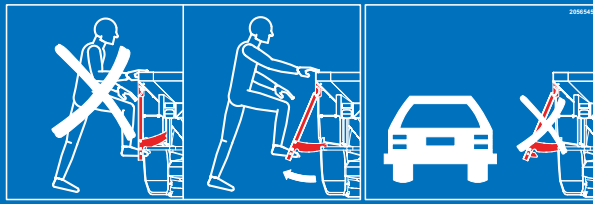

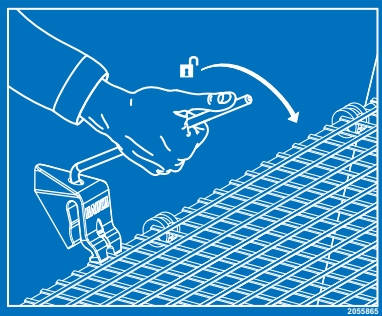
3.11.2 Instruction stickers and nameplate

	<p>Steps</p> <p>Climbing on the retracted steps is prohibited. Only climb on the steps when they are extended.</p> <p>Only travel on the road with the steps retracted.</p>
	<p>Ring eyelet in the hopper</p> <p>Bracket for fixing the hoisting gear</p>
	<p>Climbing prohibited</p> <p>Climbing on the deflector bracket is prohibited.</p>
	<p>Protective grid lock</p> <p>The grid is automatically locked when the protective grid in the hopper is closed properly. It can only be unlocked by using a tool.</p>
	<p>Rated speed of the PTO shaft</p> <p>The rated speed of the PTO shaft is 750 rpm.</p>
	<p>Maximum load capacity</p>

### 3.12 Homologation sign

**NOTICE**

When delivering your machine, ensure that all necessary signs are present.

- Depending on the country of destination, additional signs can be attached to the machine.



**Figure 3.5:** Nameplate

- [1] Manufacturer
- [2] Serial number
- [3] Machine
- [4] Type
- [5] Empty weight

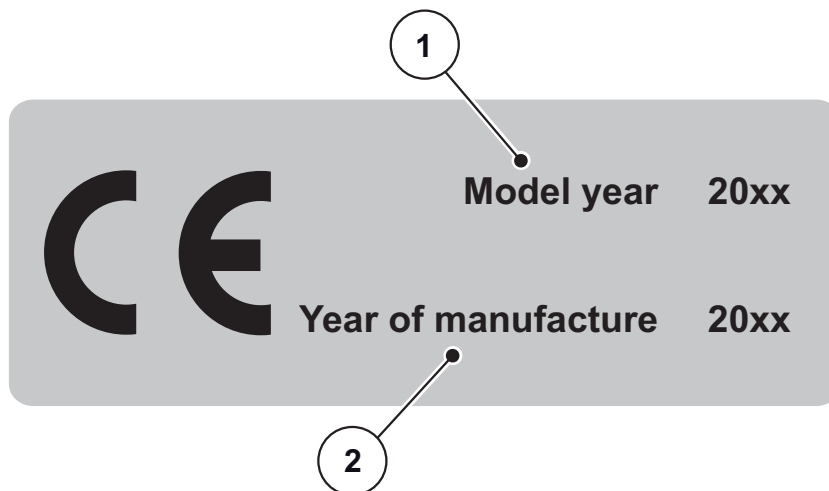

**Figure 3.6:** CE Homologation

- [1] Model year
- [2] Year of construction

### 3.13 Reflector

The machine is factory-fitted with passive front, back and side lighting (for an illustration of the positioning on the machine, see chapter [3.10.1: Position of safety equipment, page 14](#)).

## 4 Technical data

### 4.1 Hersteller

RAUCH Landmaschinenfabrik GmbH

Landstraße 14

**D-76547 Sinzheim**

Telefon: +49 (0) 7221 / 985-0

Telefax: +49 (0) 7221 / 985-200

#### **Servicezentrum, Technischer Kundendienst**

RAUCH Landmaschinenfabrik GmbH

Postfach 1162

**D-76545 Sinzheim**

Telefon: +49 (0) 7221 / 985-250

Telefax: +49 (0) 7221 / 985-203

### 4.2 Description of the machine

Use the machines of the AXIS series in accordance with the chapter [„Intended use“ on page 1](#).

The machine consists of the following assemblies.

- 2-chamber hopper with agitators and discharges
- Frame and coupling points
- Drive elements (drive shaft and transmission)
- Metering elements (agitator, metering slide, scale for the spreading volume)
- Elements for adjusting the working width
- Safety equipment; see [„Safety equipment at the machine“ on page 14](#).

#### **NOTICE**

Some models are not available in all countries.

4.2.1 Assembly overview

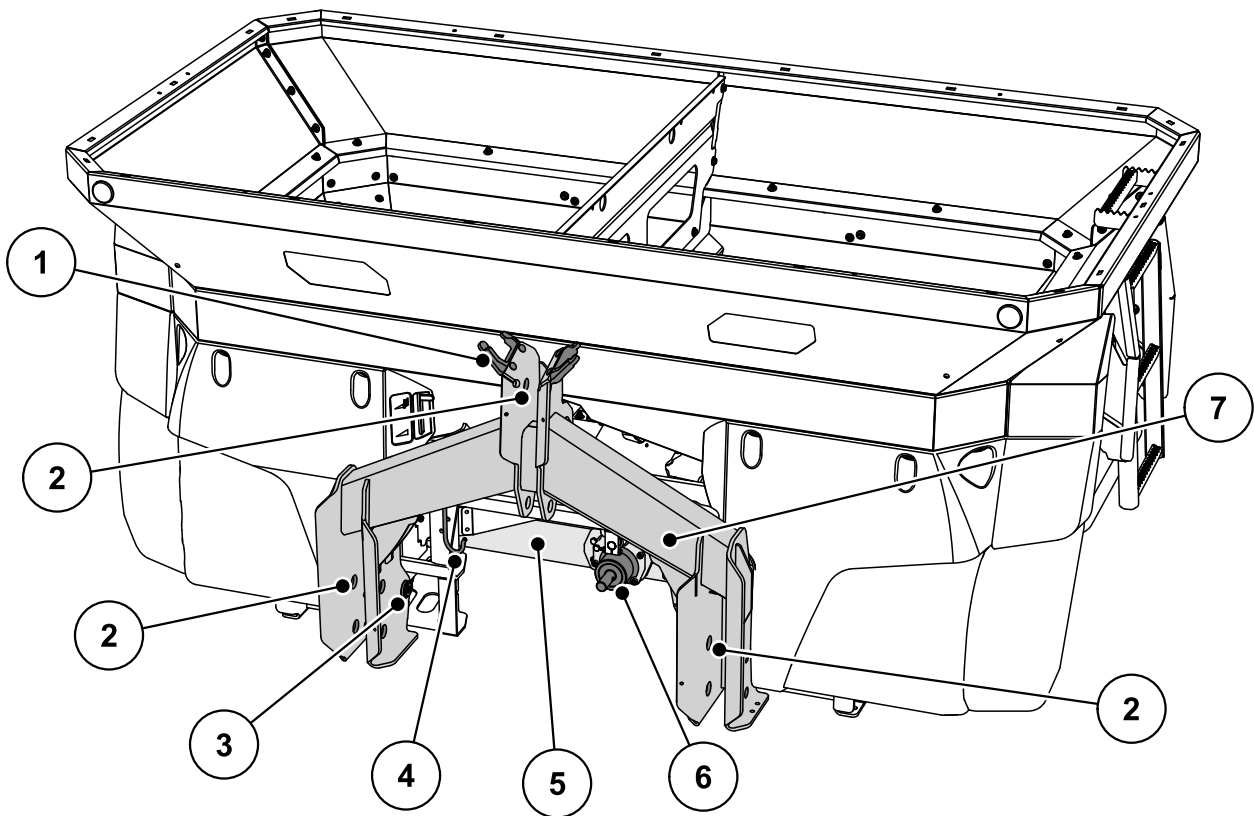

**Figure 4.1:** Assembly overview: Front

- [1] Hose and cable tray
- [2] Coupling points
- [3] Weigh cells
- [4] Drive shaft mounting bracket
- [5] Gearbox
- [6] Gearbox stub
- [7] Weigh frame

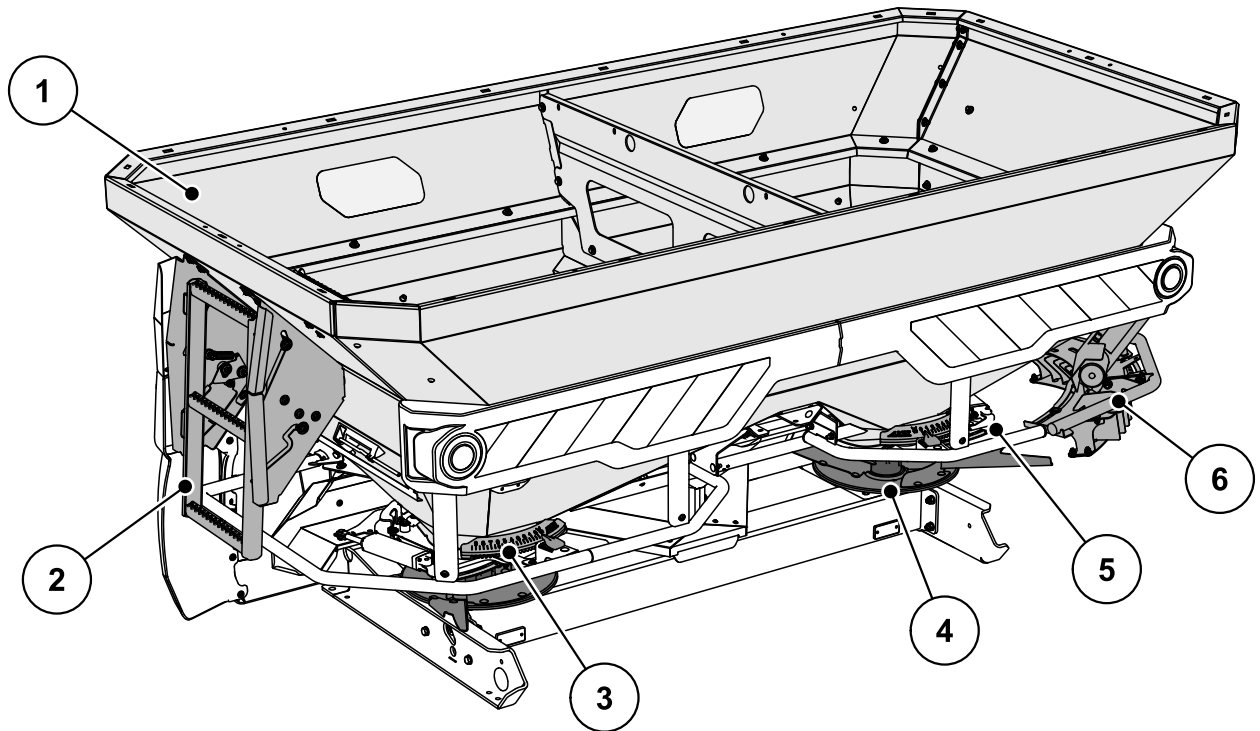

**Figure 4.2:** Assembly overview: Rear

- [1] Hopper (inspection window, filling level scale)
- [2] Steps
- [3] Drop point adjustment centre (left/right)
- [4] Spreading disc (left/right)
- [5] Scale for the spreading volume (left/right)
- [6] TELIMAT border and boundary setting

### 4.2.2 Transmission for the M EMC function

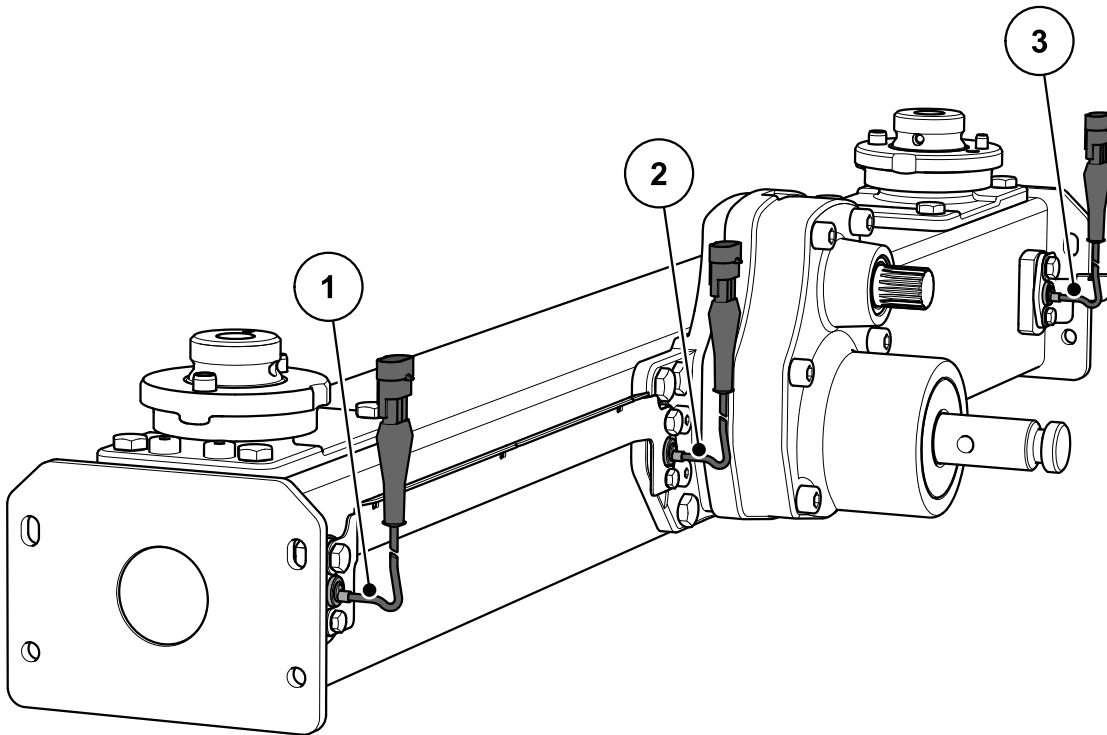

**Figure 4.3:** Mass flow control by measuring the torque of the spreading discs: AXIS-M 50.2 EMC

- [1] Right speed sensor (direction of travel)
- [2] Reference speed sensor
- [3] Left speed sensor (direction of travel)

### 4.2.3 Agitator

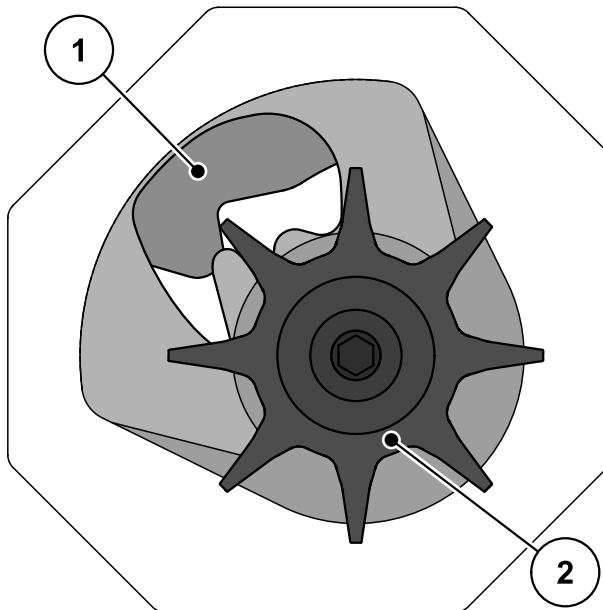

**Figure 4.4:** Agitator

- [1] Metering slide
- [2] Agitator

### 4.3 Machine data

#### 4.3.1 Versions

**NOTICE**

Some models are not available in all countries.

Function	Version	
	W	D
Spreading depending on forward speed	•	
Mass flow control by means of weigh cells	•	
Electrical drop point setting	•	
VariSpread	•	
Double-acting hydraulic cylinder		•

Type	AXIS 50.2 EMC	AXIS 50.2 EMC + W
Mass flow control (EMC) by measuring the torque of the spreading discs	•	•
Spreading depending on forward speed	•	•
RPM display	•	•
Weigh cells		•
VariSpread	•	•

## 4 Technical data

### 4.3.2 Technical data of basic equipment

#### Dimensions:

Data	AXIS 50.2 AXIS 50.2 EMC
Overall width	290 cm
Overall length	161.0 cm
Filling height (basic machine)	131 cm
Distance between centre of gravity and lower link point	74.5 cm
Filling width	270 cm
Working width <sup>1</sup>	18 - 50 m
PTO speed	min. 580
	max. 920
Capacity	2,200 l
Mass flow <sup>2</sup>	max. 500 kg/min
Hydraulic pressure	max. 200 bar
Sound pressure level <sup>3</sup> (measured in the closed driver's cab of the tractor)	75 dB(A)

1. Working width depending on fertiliser and disc type

2. Max. mass flow depending on fertiliser type

3. Since the sound pressure level of the machine can only be determined when the tractor is running, the actual measured value is greatly dependent on the tractor type being used.



**Weights and loads:**
**NOTICE**

The empty weight (mass) of the machine varies depending on the feature package and attachment combination. The empty weight (mass) shown on the nameplate refers to the standard version.

<b>Data</b>	<b>AXIS 50.2</b>
Empty weight	680 kg
Fertiliser payload max.	4200 kg

**4.3.3 Technical data of the extensions**

For machines of the AXIS series, various extensions are available. The capacity, dimensions and weights may change depending on the selected feature package.

<b>Extension</b>	<b>AXIS 50.2</b>	
	<b>GLW1000</b>	<b>GLW2000</b>
Change in capacity	+ 1000 l	+ 2000 l
Change in filling height	+ 22 cm	+ 44 cm
Extension size max.	290 x 150 cm	
Extension weight	52 kg	86 kg
Description	4-sided	4-sided

### 4.4 List of available accessories

#### NOTICE

We recommend that you have the extra equipment fitted and mounted on the basic machine by your supplier or an authorised service centre.

---

#### NOTICE

The available special equipment depends on the country of use of the machine and is not listed fully here.

- Contact your dealer/importer if you need specific special equipment.
- 

#### 4.4.1 Extensions

You can increase the capacity of the basic equipment by fitting a hopper extension. The extensions are bolted to the standard hopper.

#### NOTICE

An overview of the extensions can be found in chapter [4.3.3: Technical data of the extensions, page 27](#).

---

#### 4.4.2 Hopper cover

A hopper cover can be fitted to protect the spreading material from humidity. The hopper cover is screwed both to the main hopper as well as to the additionally mounted hopper extensions.

Hopper cover	Application
AP-L 50, foldable	● Extensions: GLW1000, GLW2000

#### 4.4.3 Electrical remote control of the hopper cover AP drive

With this remote control, you can electrically fold in and out the hopper cover from the cabin of the tractor.

#### 4.4.4 Tele-Space universal drive shaft

The Tele-Space universal drive shaft is extendible and provides additional space (approx. 300mm) for easier coupling of the machine to the tractor.

When delivering the Tele-Space drive shaft, separate assembly instructions are supplied.

#### 4.4.5 Auxiliary lighting

The machine can be fitted with auxiliary lighting.

Lighting	Application
BLF 25/50	<ul style="list-style-type: none"> <li>● Lighting for front</li> <li>● with warning sign</li> <li>● for wide extensions</li> </ul>
BLF	<ul style="list-style-type: none"> <li>● Lighting for front</li> <li>● without warning sign</li> <li>● for wide extensions</li> </ul>

#### NOTICE

The lighting mounted ex works depends on the country of use of the attachment.

- Contact your dealer/importer if you need rear lighting.

#### NOTICE

Attachments are subject to the lighting regulations specified in the traffic regulations.

- Observe the traffic regulations of your country.

#### 4.4.6 Stabilising rollers with bracket ASR 25

For parking and manually moving the empty machine.

The stabilising rollers consist of two turning wheels in front and two non-turning wheels at the rear without wheel lock.

#### 4.4.7 Limited border spreading unit GSE 60

Limits the spreading width (either towards the left or right) to a range between approx. 0 m and 3 m from the centre of the tractor to the outer edge of the field. The metering slide that points to the field edge is closed.

- Fold the boundary spreading unit downwards for boundary spreading.
- The border spreading unit must be folded up again before starting the two-sided spreading.

#### 4.4.8 Hydraulic remote control FHD 30-60 for GSE 60

This remote control is used from the tractor cabin to hydraulically swing the border spreading unit into position or to swing it from border spreading position into the two-sided spreading position.

For operating the FHD 30-60 hydraulic remote control, a double-acting control valve is required.

### 4.4.9 Spreader vane set Z14, Z16, Z18

This set of spreader vanes is used for spreading anti-slug bait. The anti-slug bait spreader vane replaces the short spreading vane on the right and left spreading disc.

Set	Application
Z14	● Spreading disc S4
Z16	● Spreading disc S6
Z18	● Spreading disc S8

### 4.4.10 Practice test kit PPS5

For checking the cross-distribution in the field.

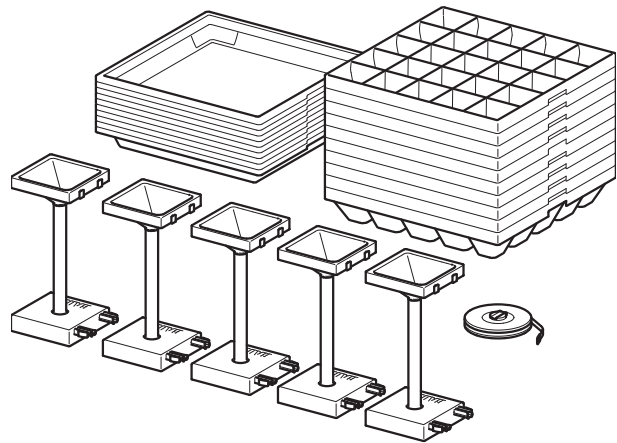

### 4.4.11 Fertiliser identification system DIS

Fast and uncomplicated determination of spreader settings when working with unfamiliar fertilisers.

### 4.4.12 Fertiliser chart booklet

The newest fertiliser charts can now be accessed at all times online or via the fertiliser chart app.

However, if you need a printed version of the fertiliser charts, you can order them from your dealer/importer.

### 4.4.13 SpreadLight operating lights

The SpreadLight special equipment supports the user in visually checking the individual spreading functions during the spreading operation in the dark.

The SpreadLight special equipment consists of an intensive LED light and is targeted onto the spreading compartments. Potential incorrect settings or blocks in the metering slides are immediately recognized.

Additionally, they allow the user to more quickly react to objects or danger zones in the external spreading area which are hard to detect, especially in the event of large working widths, when it is dark.

## 5 Axle load calculation

### ⚠ CAUTION



#### Risk of overload

Mounted units on the front or rear three-point linkage must not cause the approved total weight to be exceeded. The front axle of the tractor must be loaded with a minimum weight of 20 % of the empty weight of the tractor at all times.

- ▶ Before using the machine, ensure that these conditions are met.
- ▶ Implement the following calculations or weigh the tractor-machine combination.

Calculation of total weight, axle loads and tyre load capacity as well as of the required minimum ballast weights.

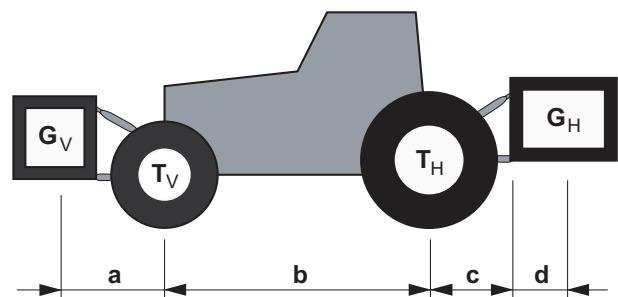

Figure 5.1: Loads and weights

You will need the following data for the calculation:

Character [unit]	Meaning	Calculation by (table footer)
$T_L$ [kg]	Empty weight of the tractor	[1]
$T_V$ [kg]	Front axle load of the empty tractor	[1]
$T_H$ [kg]	Rear axle load of the empty tractor	[1]
$G_V$ [kg]	Total weight of front-mounted unit/front ballast	[2]
$G_H$ [kg]	Total weight of rear-mounted unit/rear ballast	[2]
$a$ [m]	Distance between centre of gravity of front-mounted unit / front ballast and centre of front axle	[2], [3]
$b$ [m]	Wheel base of the tractor	[1], [3]
$c$ [m]	Distance between centre of rear axle and centre of lower link ball	[1], [3]
$d$ [m]	Distance between centre of lower link ball and centre of gravity of rear-mounted unit / rear ballast	[2]

[1] See operator's manual of the tractor

[2] See price list and/or operator's manual of the unit

[3] To be measured

**Rear-mounted unit and/or front-rear combinations**

Calculation of the minimum ballast front  $G_{V \min}$

$$G_{V \min} = \frac{(G_H \cdot (c + d) - T_V \cdot b + 0,2 \cdot T_L \cdot b)}{a + b}$$

Enter the calculated minimum ballast requirement in the table.

**Front-mounted unit**

Calculation of the minimum ballast rear  $H_{H \min}$

$$G_{H \min} = \frac{(G_V \cdot a - T_H \cdot b + 0,45 \cdot T_L \cdot b)}{b + c + d}$$

Enter the calculated minimum ballast requirement in the table.

If the front-mounted unit ( $G_V$ ) is lighter than the minimum ballast at the front ( $G_{V \min}$ ), the weight of the front-mounted unit must be increased to at least the weight of the minimum front ballast.

Calculation of the actual front axle load  $T_{V \text{tat}}$

$$T_{V \text{tat}} = \frac{(G_V \cdot (a + b) + T_V \cdot b - G_H \cdot (c + d))}{b}$$

Enter the calculated actual front axle load as well as the admissible front axle load specified in the tractor's operator's manual in the table.

If the rear-mounted unit ( $G_H$ ) is lighter than the minimum ballast at the rear ( $G_{H \min}$ ), the weight of the rear-mounted unit must be increased to at least the weight of the minimum rear ballast.

Calculation of the actual total weight  $G_{\text{tat}}$

$$G_{\text{tat}} = (G_V + T_L + G_H)$$

Enter the calculated actual total weight as well as the admissible total weight specified in the tractor's operator's manual in the table.

Calculation of the actual rear-axle load  $T_{H \text{tat}}$

$$T_{H \text{tat}} = (G_{\text{tat}} - G_{V \text{tat}})$$

Enter the calculated actual rear axle load as well as the admissible rear axle load specified in the tractor's operator's manual in the table.

Tyre load capacity

Enter double the value (two tyres) of the admissible tyre load capacity (for example, see the tyre manufacturer's documentation) in the table.

**Axle loads table:**

	<b>Actual value according to calculation</b>	<b>Admissible value according to operator's manual</b>	<b>Twice the admissible tyre load capacity (two tyres)</b>
Minimum ballast front / rear	<input type="text"/> kg	—	—
Total weight	<input type="text"/> kg	$\leq$ <input type="text"/> kg	—
Front axle load	<input type="text"/> kg	$\leq$ <input type="text"/> kg	$\leq$ <input type="text"/> kg
Rear axle load	<input type="text"/> kg	$\leq$ <input type="text"/> kg	$\leq$ <input type="text"/> kg

The minimum ballast must be mounted on the tractor as an attachment or as ballast weight.

The calculated values must be less than or equal to the admissible values.





## 6 Transportation without tractor

### 6.1 General safety instructions

**Read the following instructions before transporting the machine:**

- If no tractor is used, the machine may only be transported with an empty hopper.
- The work may only be carried out by suitable, trained and expressly authorised personnel.
- Suitable means of transportation and lifting equipment (e.g. crane, forklift truck, lifting tackle ...) are to be used.
- Determine the transportation route early, and remove possible obstacles.
- Check that all safety and transportation devices are fully operational.
- Secure all danger areas appropriately, even if they only exist briefly.
- The person responsible for transportation must ensure that the machine is transported appropriately.
- Unauthorised persons are to be kept away from the transport route. The areas concerned must be cordoned off.
- Cautiously transport the machine and handle it with care.
- Make sure that allowance is made for the centre of gravity. If necessary, adjust the lifting tackle so that the machine is correctly suspended.
- Transport the machine to the final destination as close to the ground as possible.

### 6.2 Loading and unloading, parking

1. Determine the weight of the machine.  
Details are provided on the nameplate.  
If applicable, also take the weight of mounted special equipment into account.
2. Carefully lift the machine with suitable lifting equipment.
3. Carefully set the machine down on the loading platform of the transport vehicle or on solid ground.



## 7 Commissioning

### 7.1 Accepting the machine

When accepting the machine, please check the completeness of the delivery.

**The standard equipment includes:**

- 1 mineral fertiliser spreader of the AXIS series,
- 1 operator's manual AXIS 50.2
- 1 calibration kit including chute
- Lower link and upper link pins
- 1 spreading disc set (according to order)
- 1 universal drive shaft (including operator's manual)
- 1 agitator
- Protective grid in hopper
- Version D: QUANTRON-A control unit
- Version W, EMC (+W): ISOBUS machine control unit AXIS ISOBUS

Please also check any optional equipment that you ordered.

Check for any shipping damage or missing parts. Have any shipping damage confirmed by the forwarding agent.

#### **NOTICE**

When receiving the machine, check that all attached components are correctly and tightly seated.

The right-hand spreading disc and left-hand spreading disc must be mounted facing the direction of travel.

---

If in doubt, contact your dealer or the factory directly.

### 7.2 Requirements for the tractor

To ensure a safe and correct use of the machine of the AXIS series, the tractor must meet the necessary mechanical, hydraulic, and electrical requirements.

- Universal drive shaft connection: 1 3/8 inches, 6-part, 700rpm,
- Oil supply: max. 200 bar, single or double-acting valve (depending on equipment)
- Operating voltage: 12 V,
- Three-point linkage, category III

### 7.3 Mounting the universal drive shaft at the machine

#### ⚠ CAUTION



#### Material damages due to unsuitable drive shaft

The machine is delivered with a drive shaft that is designed according to the device and performance.

The use of incorrectly dimensioned or inadmissible drive shafts, for instance without guard or suspension chain, may cause personal injury or lead to damage to the tractor and/or the machine.

- ▶ Use universal drive shafts approved by the manufacturer only.
- ▶ Follow the directions in the operator's manual of the universal drive shaft manufacturer.

Depending on the version, the machine may be equipped with different universal drive shafts:

- Transmission with radial pin clutch,
- Tele-Space transmission with radial pin clutch.
- Check the mounting position.
  - The drive shaft end that is marked with a tractor symbol must point to the tractor.

1. Remove the protective cap.
2. Loosen the locking screw [1] of the universal drive shaft guard.
3. Turn the universal drive shaft guard to the demounting position.
4. Pull the universal drive shaft out.

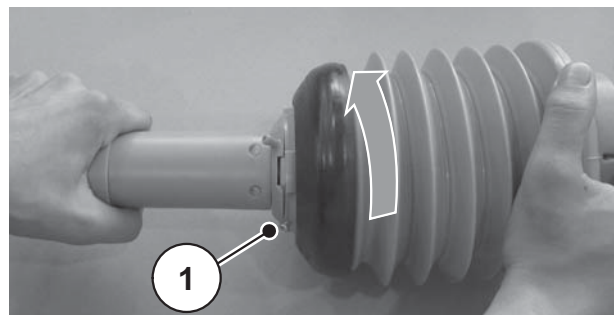

**Figure 7.1:** Loosen the universal drive shaft guard

**Mounting:**

1. Remove the spigot protection and grease the transmission spigot.
2. Push the universal drive shaft onto the transmission spigot.

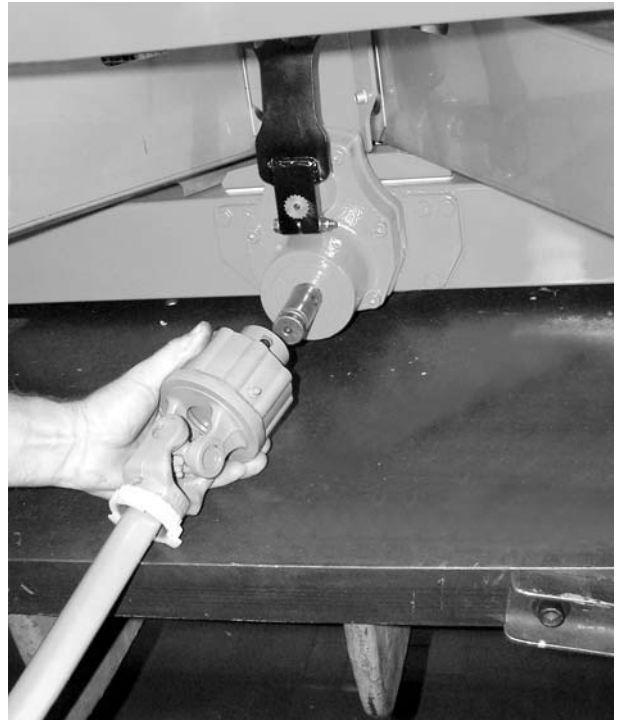

**Figure 7.2:** Push the universal drive shaft onto the transmission spigot

3. Tighten the hex cap screw and nut using a size 17 wrench (max. 35 Nm).

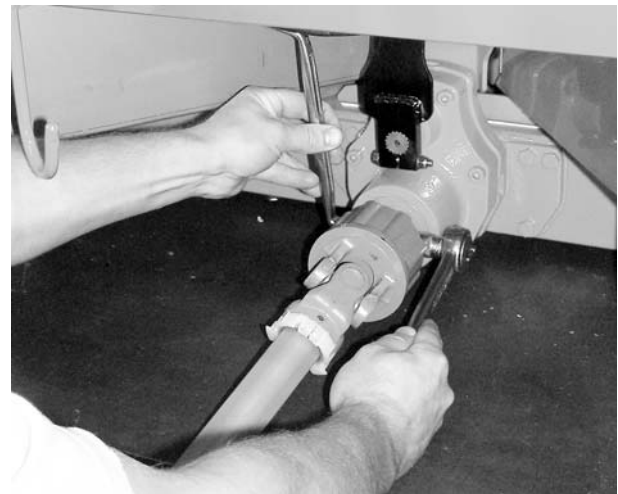

**Figure 7.3:** Tighten the universal drive shaft

4. Push the drive shaft guard with hose clamp over the drive shaft and loosely attach it to the extension housing of the transmission (do not tighten).
5. Turn the universal drive shaft guard to the locking position.



**Figure 7.4:** Put the universal drive shaft guard back on

6. Tighten the locking screw.
7. Tighten the hose clamp.

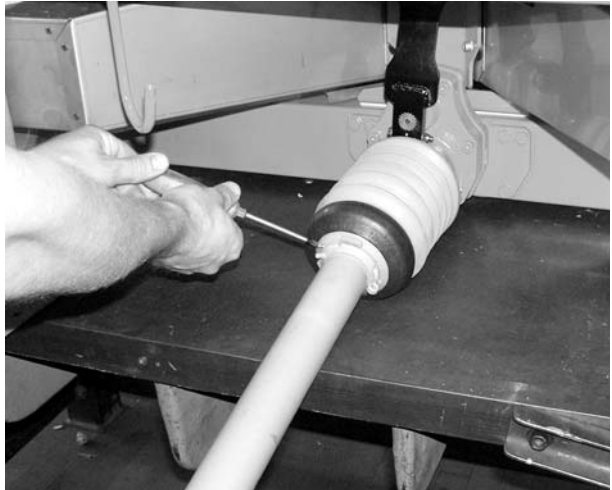

**Figure 7.5:** Secure the universal drive shaft guard

**Instructions for dismounting:**

- Dismount the universal drive shaft in reverse order of attachment.
- Never use the suspension chain for suspending the drive shaft.
- Always put dismantled drive shafts in the provided bracket [2].
  - See [figure 7.6](#).

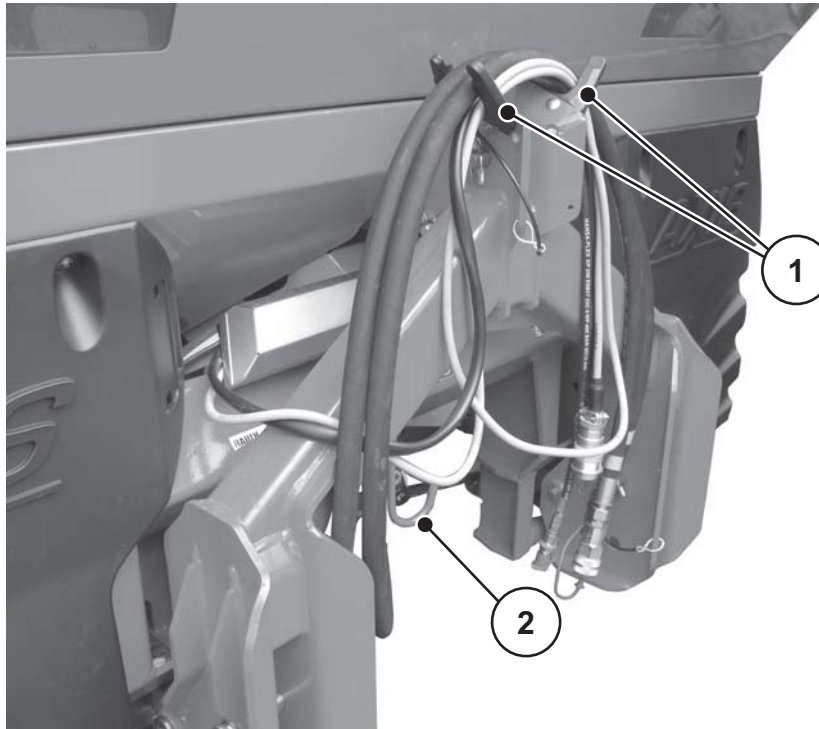

**Figure 7.6:** Storage of the cables and hydraulic hoses

- [1] Bracket for hoses and cables  
[2] Universal drive shaft bracket

## 7.4 Installing the machine on the tractor

### 7.4.1 Requirements

#### **⚠ DANGER**



#### **Danger to life due to unsuitable tractor**

Using an unsuitable tractor for the machine may result in severe accidents during operation or road travel.

- ▶ Only use tractors that comply with the technical requirements of the machine.
- ▶ Use the vehicle's documentation to check if your tractor is suitable for the machine.

#### **Check the following specific requirements:**

- Are both the tractor and the machine in a reliable condition?
- Does the tractor comply with the mechanical, hydraulic, and electrical requirements?
  - See ["Requirements for the tractor" on page 38](#).
- Do the attachment categories of the tractor and the machine match (if necessary, consult your dealer)?
- Is the machine securely positioned on level and solid ground?
- Do the axle loads conform to the stipulated calculations?
  - See ["Axle load calculation" on page 31](#).

#### **Position of the distance washers**

Ensure the correct position of the distance washers [2] included in the scope of delivery on each side of the lower link ball [1].

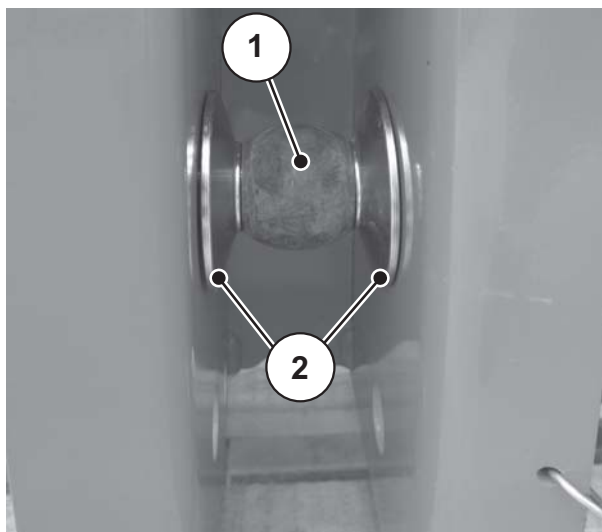

**Figure 7.7:** Position of the distance washers when installing the machine



## 7.4.2 Attachment

**⚠ DANGER****Danger to life due to inattention or faulty operation.**

There is a crushing hazard that may result in fatal injury for persons standing between the tractor and the machine when the tractor approaches or the hydraulic system is actuated.

The tractor may brake too late or not at all because of inattention or faulty operation.

- ▶ Ensure that nobody is present in the hazard zone between the tractor and the machine.

The machine is installed at the three-point linkage (rear power lift) of the tractor.

**NOTICE**

For normal fertilisation and late fertilising, **always** use the **upper coupling points** of the machine. See [figure 7.8](#).

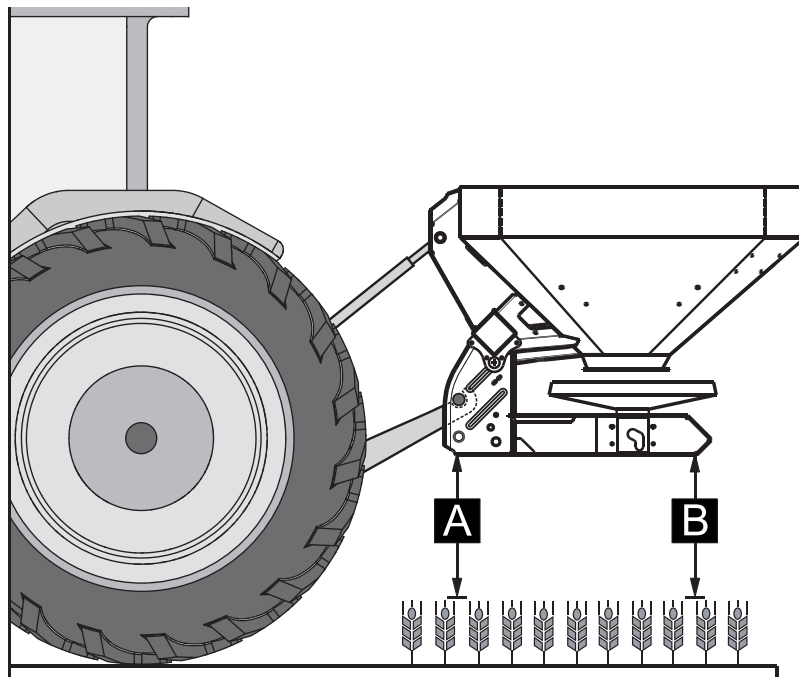

Figure 7.8: Mounting position

### Mounting instructions

- The machine can be connected to a tractor with category IV linkage only with category III clearance. Use reducing sleeves.
  - The bottom and upper link pins must be secured with linch pins or spring clips.
  - Attach the machine according to the values in the fertiliser chart. This guarantees the correct cross-distribution of the fertiliser.
  - Any oscillating movements during spreading are to be avoided. Make sure that the machine does not have too much sideways play:
    - The lower link arms of the tractor are to be braced by means of stabilising struts or chains.
1. Start the tractor.
    - Check: The PTO shaft is switched off.
  2. Move the tractor to the machine.
    - Do not latch the lower link hooks into place yet.
    - Make sure there is enough space between the tractor and the machine in order to be able to connect the drives and control elements.
  3. Switch the tractor motor off. Remove the ignition key.
  4. Mount the drive shaft to the tractor.
    - If there is not enough space available, an extendible **Tele-Space universal drive shaft** must be used.
  5. Connect the electric and hydraulic slide actuators and the lighting.
  6. From the tractor cab, connect the lower link hooks and the upper link to the designated coupling points; please refer to the operator's manual of the tractor.

### NOTICE

We recommend using bottom link hooks together with a hydraulic upper link for safety and comfort. See [figure 7.8](#).

---

7. Check the tight seat of the machine.
8. Carefully raise the machine to the desired lifting height.

**⚠ CAUTION****Material damages due to excessively long drive shaft**

When the machine is lifted up, the universal drive shaft halves can come into contact inside each other. This can cause damage to the drive shaft, the transmission or the machine.

- ▶ Check the clearance between the machine and the tractor.
- ▶ Make sure there is enough space (at least 20 to 30mm) between the outer pipe of the drive shaft and the protective cone on the spreader side.

- 
9. Shorten the universal drive shaft, if required.

**NOTICE**

**Only** your dealer or your specialist workshop may shorten the universal drive shaft.

**NOTICE**

Observe the installation and shortening instructions provided in the **operator's manual of the drive shaft manufacturer** when checking and adjusting the drive shaft. The operator's manual is attached to the drive shaft on delivery.

- 
10. Preset the mounting height according to the fertiliser chart. See [7.8.2: Settings as per fertiliser chart, page 54](#).

## 7.5 Connecting the metering slide actuator

### 7.5.1 Connecting the hydraulic slide actuators: Version D

#### Requirements for the tractor

- two **double-acting** control valves

#### Function

The opening slides are actuated separately by two hydraulic cylinders. The hydraulic cylinders are connected to the slide actuation on the tractor via hydraulic hoses.

Version	Hydraulic cylinder	Operation
D	Double-acting hydraulic cylinder	The oil pressure closes. The oil pressure opens.

#### Attachment

1. Depressurise the hydraulic system.
2. Remove the hoses from the brackets attached to the frame of the machine.
3. Insert the hoses into the corresponding couplings on the tractor.

### 7.5.2 Connecting the electronic slide actuator: Version W

#### **NOTICE**

The machine version W is equipped with an electronic metering slide actuator. The electronic slide actuator is described in a separate operator's manual for the operating unit. This operator's manual is an integral part of the operating unit.

---

## 7.6 Presetting the mounting height

### 7.6.1 Safety

#### ⚠ DANGER



#### Risk of being crushed under the falling-down machine

If the upper link halves are accidentally rotated totally apart from each other, it may happen that the upper link cannot compensate for the tractive forces of the machine. This may result in the machine abruptly tilting over backwards or falling down.

This can lead to severe personal injury. Machines can be damaged.

- ▶ When extending the upper link, always observe the maximum admissible length specified by the tractor or upper link manufacturer.
- ▶ Ensure that nobody is present in the hazard zone of the machine.

#### ⚠ WARNING



#### Risk of injury from rotating spreading discs!

The distribution unit (spreading disc, vanes) may catch and pull-in body parts or objects. Contact with the distribution unit may injure, crush or cut off body parts.

- ▶ Maximum admissible mounting heights at front (V) and rear (H) are to be complied with at all times.
- ▶ Ensure that nobody is present in the hazard zone of the machine.
- ▶ Never remove deflectors mounted on the hopper.

#### General instructions before setting the mounting height

- We recommend that you choose the highest coupling point on the tractor to connect the upper link, particularly for high lifting heights.

#### NOTICE

For normal fertilisation and late fertilising, **always** use the **upper coupling points** of the machine.

- The lower coupling points on the machine which are meant for the lower links of the tractor should be used **only in exceptional circumstances** in late fertilising.

7.6.2 Maximum admissible mounting height at front (V) and rear (H)

The **maximum** admissible mounting height (**V + H**) is measured **from the ground** to the lower edge of the frame.

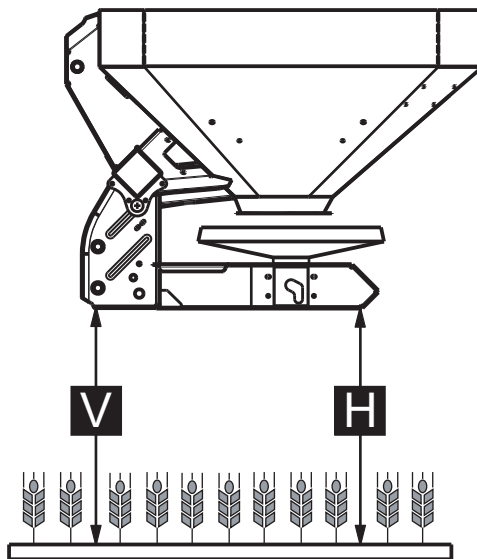

**Figure 7.9:** Maximum admissible mounting height V and H during normal and late fertilising

The maximum admissible mounting height depends on the following factors:

- Normal fertilisation or late fertilising.

	Maximum admissible mounting height	
	V [mm]	H [mm]
<b>Normal fertilisation</b>	990	990
<b>Late fertilising</b>	900	960

### 7.6.3 Mounting heights A and B according to fertiliser chart

The mounting heights in the fertiliser chart (**A and B**) are always measured in the field from the top of the **crop height** to the bottom edge of the frame.

#### NOTICE

The values of A and B can be taken from the **fertiliser chart**.

#### Setting the mounting height during normal fertilisation

Requirements:

- The machine is installed at the highest connecting point of the upper link at the tractor.
- The lower link of the tractor is installed at the **upper coupling point of the lower link** of the machine.

Proceed as follows when determining the mounting height (in normal fertilisation):

1. Determine the mounting heights **A and B** (above crop height) from the fertiliser chart.
2. Compare the mounting heights **A and B** plus the crop height with the maximum admissible mounting heights at the front (V) and rear (H).

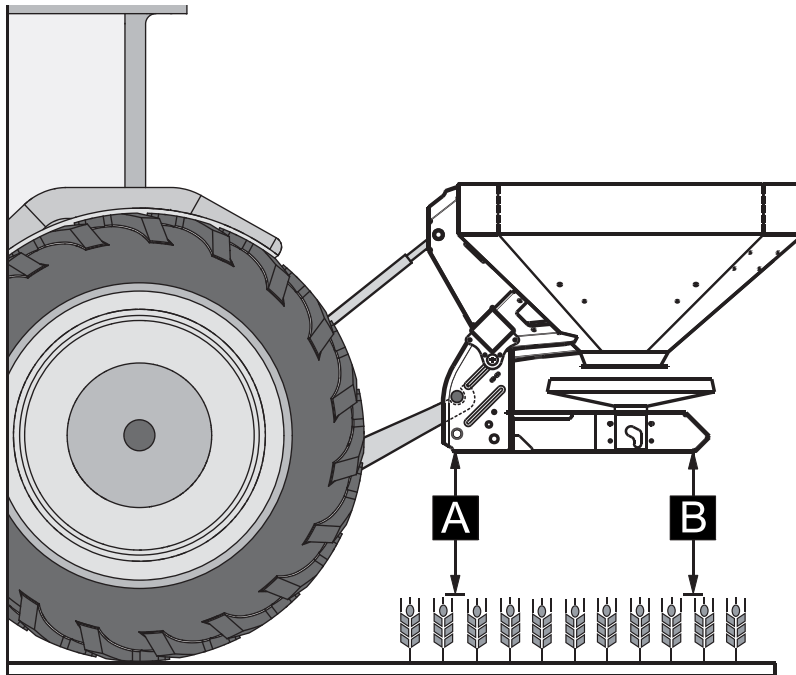

**Figure 7.10:** Mounting position and height during normal fertilisation

The following applies:

A + crop height ≤ V	Max. 990 mm
B + crop height ≤ H	Max. 990 mm

3. If the maximum admissible mounting height of the machine is exceeded in the normal fertilisation mode, or if the mounting heights A and B cannot be reached: The machine is to be mounted according to the **late fertilising** values.



### Setting the mounting height during late fertilising

Requirements:

- The machine is installed at the highest connecting point of the upper link at the tractor.
- The lower link of the tractor is installed at the **upper coupling point of the lower link** of the machine.

Proceed as follows when determining the mounting height (in late fertilising mode):

1. Determine the mounting heights **A** and **B** (above crop height) from the fertiliser chart.
2. Compare the mounting heights **A** and **B** plus the crop height with the maximum admissible mounting heights at the front (V) and rear (H).

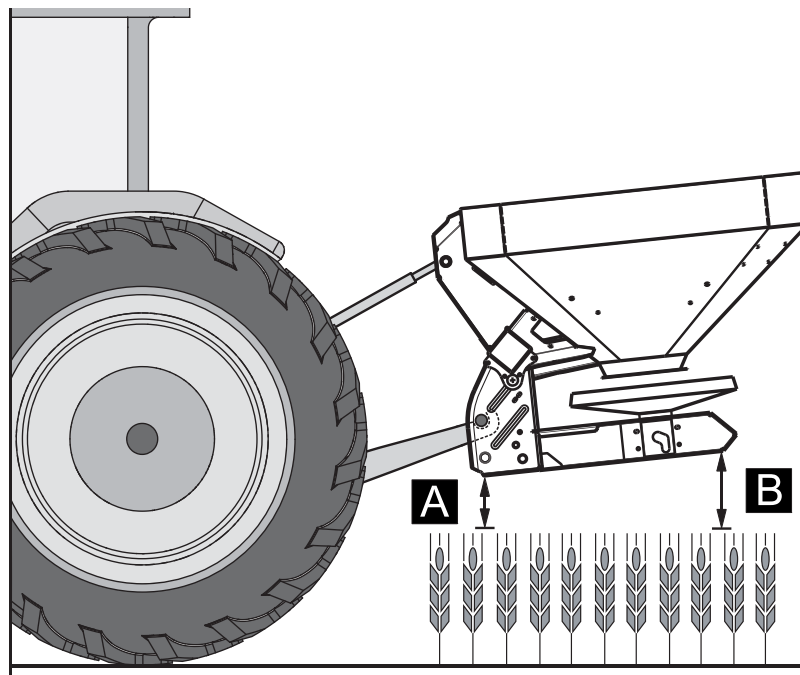

**Figure 7.11:** Mounting position and height during late fertilising

The following applies:

A + crop height $\leq$ V	Max. 900 mm
B + crop height $\leq$ H	Max. 960 mm

- If the lifting height of the tractor is insufficient for setting the required mounting height: use the lower coupling point on the lower link of the machine.

**NOTICE**

Make sure that the **maximum admissible length** specified by the upper link or tractor manufacturer is not exceeded.

- Please observe the instructions in the operator's manual provided by the tractor and upper link manufacturer.

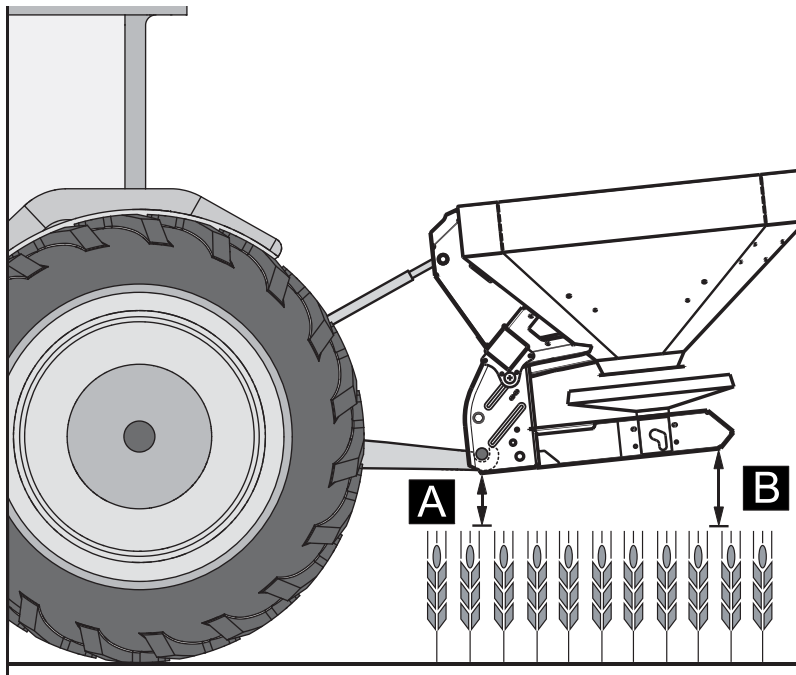

**Figure 7.12:** Machine mounted to the lower coupling point of the lower link

The following applies:

A + crop height ≤ V	Max. 900 mm
B + crop height ≤ H	Max. 960 mm

## 7.7 Filling the machine

### ⚠ DANGER



#### Danger of injury from running engine

Working on the machine while the engine is running may result in serious injuries caused by mechanical components and escaping fertiliser.

- ▶ Switch the tractor motor off.
- ▶ Remove the ignition key.
- ▶ Ensure that nobody is present in the hazard zone.

### ⚠ CAUTION



#### Inadmissible overall weight

If the permissible total weight is exceeded, this will affect the operating and road safety of the vehicle (machine and tractor) and may cause serious damage to the machine and the environment.

- ▶ Before you start filling, calculate the amount you can load.
- ▶ Comply with the permissible overall weight.

#### Instructions on filling the machine:

- **Only** fill the machine when it is attached to the tractor. Make sure that the tractor is standing on level and solid ground.
- Secure the tractor against rolling away. Apply the handbrake.
- Turn the tractor motor off.
- Remove the ignition key.
- For filling heights of more than 1.25 m, fill the machine by means of suitable auxiliary equipment (e.g. front loader or screw conveyor).
- Check the filling level e.g. with the steps being folded out or by means of the inspection window in the hopper (depending on type).

#### Filling level scale (not for weighing spreaders)

A filling level scale is installed in the hopper to monitor the filling level.

This scale can be used to estimate how long spreading can continue until you must refill the hopper.

### 7.8 Using the fertiliser chart

#### 7.8.1 Information on the fertiliser chart

The values in the fertiliser chart have been determined using the test system of the manufacturer.

The used fertiliser materials have been purchased from the fertiliser manufacturers or from dealers. Experience shows that, due to storage, transportation and other reasons, the fertiliser materials at your disposal - even with identical specification - might exhibit a different spreading behaviour.

This means that the machine settings specified in the fertiliser charts may result in a different spreading volume and a poorer fertiliser distribution.

**Therefore, observe the following instructions:**

- Always check the actual spreading volume discharged by performing a calibration test.
- Check the working width of the fertiliser distribution with a practice test kit (optional equipment).
- Only use fertilisers listed in the fertiliser chart.
- Contact us if you do not find a particular fertiliser type in the fertiliser chart.
- Observe the setting values exactly. Even a slightly incorrect setting may adversely affect the spreading pattern.

**When using urea, particular attention is to be paid to the following:**

- Due to a great number of fertiliser imports, urea is available in a wide variety of different qualities and grain sizes. It may therefore be required to adjust the settings of the spreader.
- Urea is more sensitive to wind and absorbs more moisture than other fertilisers.

**NOTICE**

The operator is responsible for making the correct spreader adjustments according to the fertiliser material in use.

The manufacturer of the machine points out specifically that they do not accept any liability for subsequent damage resulting from incorrect spreader adjustments.

---

#### 7.8.2 Settings as per fertiliser chart

You can determine the mounting height, fertiliser drop point, metering slide adjustment, spreading disc type and PTO speed for an optimum spreading from the **fertiliser chart** depending on the fertiliser type, working width, application rate, forward speed and fertilisation method.

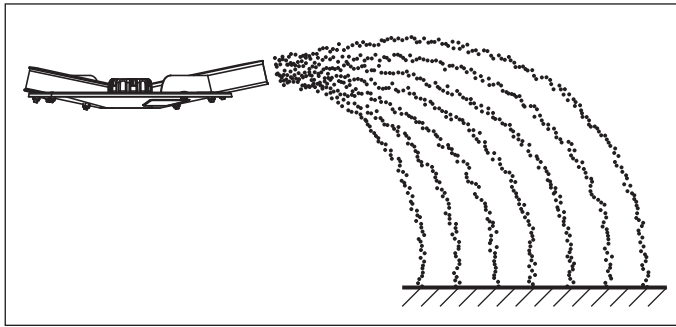
**Example of field spreading during normal fertilisation:****Figure 7.13:** Field spreading during normal fertilisation

During field spreading in normal fertilisation mode, a symmetrical spreading pattern is produced. If the spreader is correctly set (see information in the fertiliser chart), the fertiliser is evenly spread over the field.

**Specified parameters:**

Type of fertiliser:	KAS BASF
Application rate:	300 kg/ha
Working width:	24 m
Forward speed:	12 km/h

The following settings are to be applied to the machine according to the fertiliser chart:

- Mounting height: 50/50 (A = 50 cm, B = 50 cm)
- Drop point: 6
- Metering slide adjustment: 180
- Spreading disc type: S4
- PTO speed: 540 rpm

**Example of limited border spreading during normal fertilisation (Standard equipment TELIMAT):**

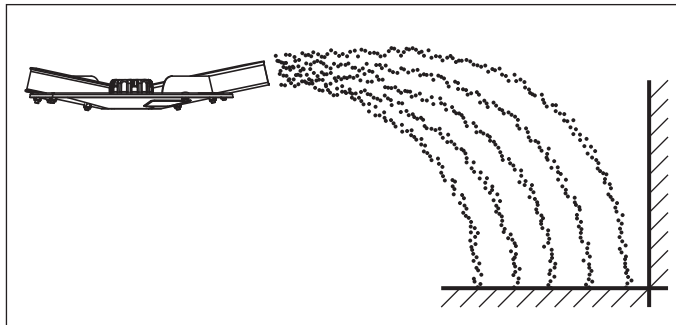

**Figure 7.14:** Limited border spreading during normal fertilisation

During limited border spreading in normal fertilisation mode, almost no fertiliser goes beyond the field boundary. Underfertilisation at the field boundary must be accepted in this case.

**Specified parameters:**

Type of fertiliser:	KAS BASF
Application rate:	300 kg/ha
Working width:	24 m
Forward speed:	12 km/h

The following settings are to be applied to the machine according to the fertiliser chart:

- Mounting height: 50/50 (A = 50 cm, B = 50 cm)
- Drop point: 6
- Metering slide adjustment: 180 left, 150 right<sup>1</sup>
- Spreading disc type: S4
- PTO speed: 540 rpm
- TELIMAT settings: K12.5

1. Recommended application rate reduction of 20% on the limited border spreading side

**Example of full border spreading during normal fertilisation  
(Standard equipment TELIMAT):**

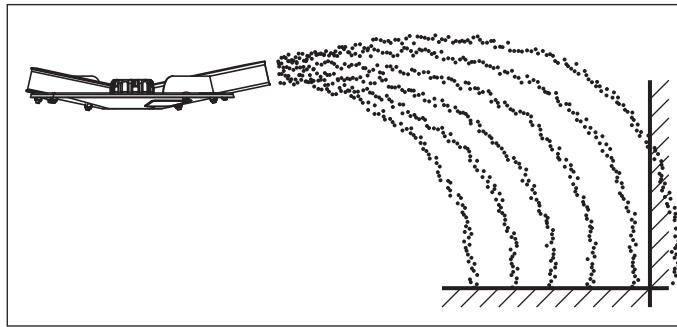

**Figure 7.15:** Full border spreading during normal fertilisation

Full border spreading in normal fertilisation mode refers to a spreading technique in which a bit more fertiliser lands beyond the boundary of the field. Therefore, there is just a slight underfertilisation at the field boundary.

**Specified parameters:**

Type of fertiliser:	KAS BASF
Application rate:	300 kg/ha
Working width:	24 m
Forward speed:	12 km/h

The following settings are to be applied to the machine according to the fertiliser chart:

- Mounting height: 50/50 (A = 50 cm, B = 50 cm)
- Drop point: 6
- Metering slide adjustment: 180
- Spreading disc type: S4
- PTO speed: 540 rpm
- TELIMAT settings: S13

**Example of field spreading during late fertilising:**

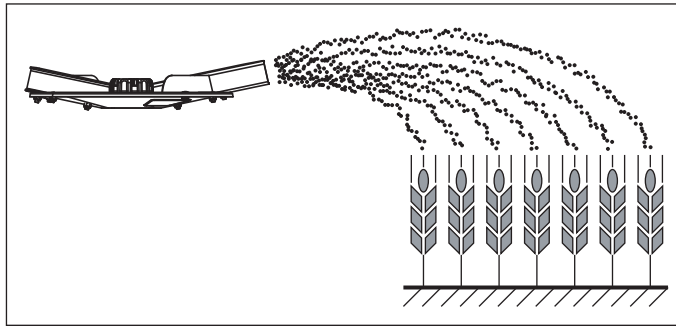

**Figure 7.16:** Field spreading during late fertilising

During field spreading in late fertilising mode, a symmetrical spreading pattern is produced. If the spreader is correctly set (see information in the fertiliser chart), the fertiliser is evenly spread over the field.

**Specified parameters:**

Type of fertiliser:	KAS BASF
Application rate:	150 kg/ha
Working width:	24 m
Forward speed:	12 km/h

The following settings are to be applied to the machine according to the fertiliser chart:

- Mounting height: 0/6 (A = 0 cm, B = 6 cm)
- Drop point: 6.5
- Metering slide adjustment: 90
- Spreading disc type: S4
- PTO speed: 540 rpm



**Example of limited border spreading during late fertilising  
(Standard equipment TELIMAT):**

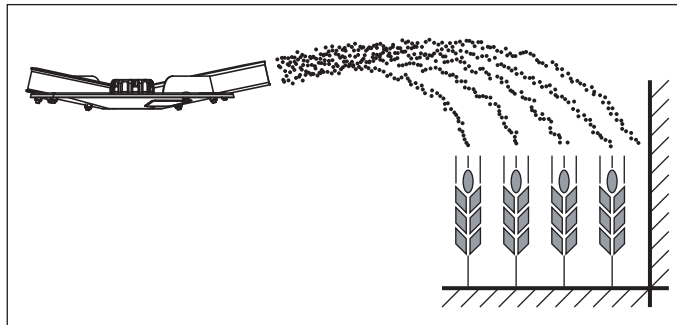

**Figure 7.17:** Limited border spreading during late fertilising

During limited border spreading in late fertilising, almost no fertiliser goes beyond the field boundary. Underfertilisation at the field boundary must be accepted in this case.

**Specified parameters:**

Type of fertiliser:	KAS BASF
Application rate:	150 kg/ha
Working width:	24 m
Forward speed:	12 km/h

The following settings are to be applied to the machine according to the fertiliser chart:

- Mounting height: 0/6 (A = 0 cm, B = 6 cm)
- Drop point: 6.5
- Metering slide adjustment: 90 left, 72 right<sup>1</sup>
- Spreading disc type: S4
- PTO speed: 540 rpm
- TELIMAT settings: K12.5

1. Recommended application rate reduction of 20% on the limited border spreading side

**Example of full border spreading during late fertilising  
(Standard equipment TELIMAT):**

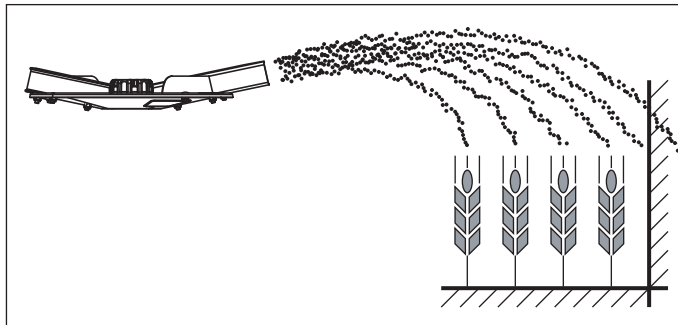

**Figure 7.18:** Full border spreading during late fertilising

Full border spreading during late fertilising refers to a spreading technique in which a bit more fertiliser lands beyond the boundary of the field. Therefore, there is just a slight underfertilisation at the field boundary.

**Specified parameters:**

Type of fertiliser:	KAS BASF
Application rate:	150 kg/ha
Working width:	24 m
Forward speed:	12 km/h

The following settings are to be applied to the machine according to the fertiliser chart:

- Mounting height: 0/6 (A = 0 cm, B = 6 cm)
- Drop point: 6.5
- Metering slide adjustment: 90
- Spreading disc type: S4
- PTO speed: 540 rpm
- TELIMAT settings: S13

## 7.9 Setting the GSE limited border spreading unit optional equipment

The border spreading unit limits the spreading width (either towards the left or right) to a range between approx. 0 m and 3 m from the centre of the tractor track to the outer edge of the field.

- Close the metering slider that points to the edge of the field.
- Fold the limited border spreading unit downwards for boundary spreading.
- The border spreading unit must be folded up again before starting the two-sided spreading.

### NOTICE

The settings for the border spreading unit refer to the **spreading disc working towards the inside of the field**.

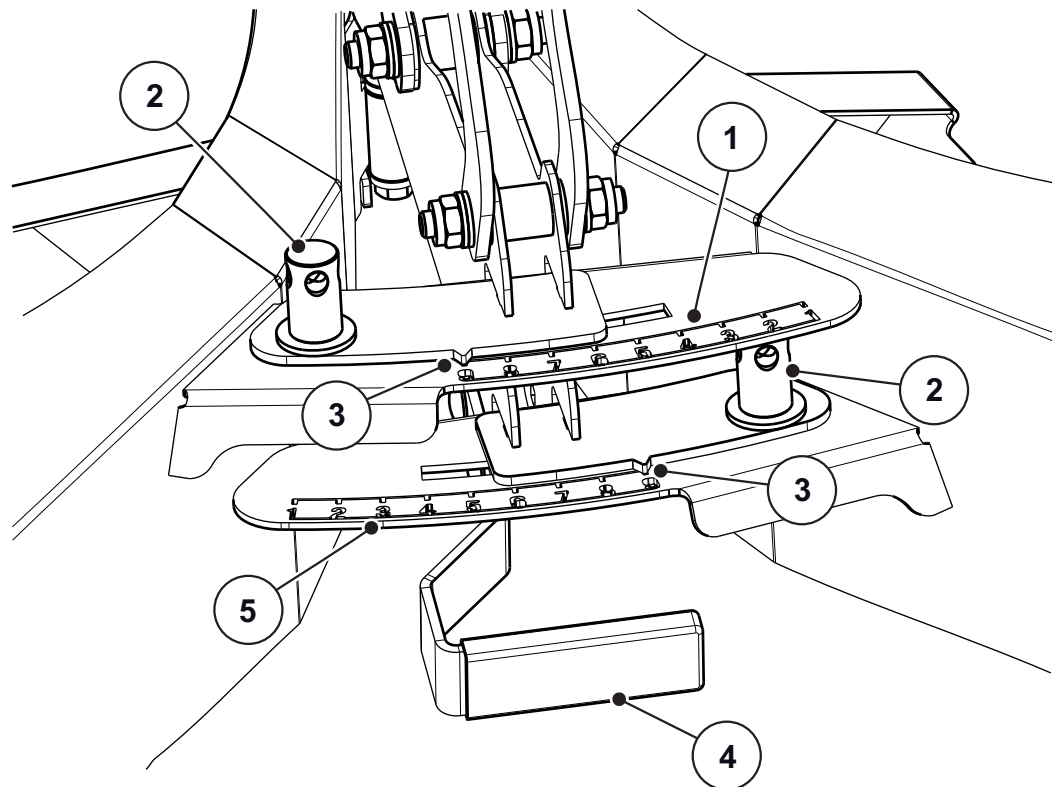

**Figure 7.19:** Setting the border spreading unit

- [1] Numeric scale, left side
- [2] Adjustment nut for numeric scale
- [3] Indicator
- [4] Hand grip
- [5] Numeric scale, right side

1. The position of the pointer [3] is to be obtained from the assembly instruction manual included in the scope of delivery.
2. Loosen the adjustment nut [2] for the numeric scale using the adjustment lever of the machine.
3. Slide the numeric scale so that the pointer is directed to the value determined. Use the hand grip [4] for this purpose.

4. Loosen the adjustment nut [2] for the numeric scale using the adjustment lever of the machine.

### **Correcting the spreading distance**

The specifications in the provided assembly manual are standard values. If there are deviations in the fertiliser quality, it may be necessary to correct the setting.

- For **reducing** the spreading distance, move towards the spreading disc (smaller numbers).
- For **increasing** the spreading distance, move away from the spreading disc (greater numbers).

## 7.10 Adjustment of standard equipment TELIMAT

The TELIMAT is a remote-controlled full and limited border spreading unit for working widths of **12 - 42 m** (or boundary spreading only, depending on the fertiliser type).

The TELIMAT T is mounted on the **right** side of the machine in the direction of travel. You can control the TELIMAT set-up from the tractor via a single-acting control valve.

### **NOTICE**

The attachment of the TELIMAT T25 to the machine is described in detail in a separate assembly instruction manual. An assembly manual is included in the scope of delivery of the TELIMAT unit.

---

### 7.10.1 Setting the TELIMAT

You prepare the TELIMAT for spreading in accordance with the **fertiliser type**, the **working width** and the desired **type of boundary spreading** (boundary or full border spreading).

### **NOTICE**

The setting values for TELIMAT can be obtained from the fertiliser chart.

---

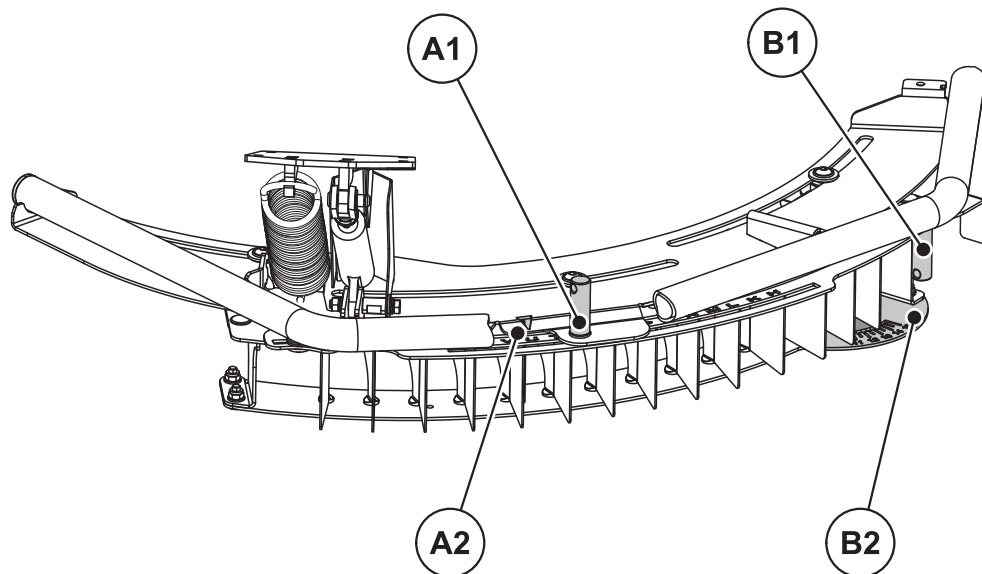

**Figure 7.20:** Setting the TELIMAT

- [A1] Adjustment nut for alphabetic scale
- [A2] Alphabetic scale for coarse adjustment
- [B1] Adjustment nut for numeric scale
- [B2] Numeric scale for fine adjustment

#### **Coarse adjustment (alphabetic scale):**

The complete TELIMAT housing can be rotated in guidings around the spreading disc pivot (alphabetic scale H to Z). The alphabetic scale is used to adjust the TELIMAT housing according to the respective fertiliser type, working width and boundary spreading type (boundary or full border spreading).

1. Loosen the adjustment nut for the alphabetic scale using the adjustment lever of the machine.
2. Move TELIMAT housing (sliding section) to the letter specified in the calibration chart.
  - ▷ The arrow is exactly above the specified letter.
3. Tighten the adjustment nut for the alphabetic scale using the adjustment lever of the machine.

#### **Fine adjustment (numeric scale):**

One-piece guiding plates are available inside the border spreading system and can be moved along a numeric scale (scale 11 to 15). The numeric scale is mainly used for fine tuning.

1. Loosen the adjustment nut for the numeric scale using the adjustment lever of the machine.
2. Move guiding plate to the number value specified in the calibration chart.
  - ▷ The specified number value is precisely aligned with the first guiding plate.
3. Tighten the adjustment nut for the numeric scale using the adjustment lever of the machine.

### 7.10.2 Correcting the spreading distance

The values in the calibration chart are standard values. If there are deviations in the fertiliser quality, it may be necessary to correct the setting.

If only minor deviations occur, it is generally sufficient to modify the guiding plate setting.

- To **decrease** the spreading distance relative to the calibration chart setting: Change the numeric scale guiding plate position in the direction of the **lesser value**.
- To **increase** the spreading distance relative to the calibration chart setting: Change the numeric scale guiding plate position in the direction of the **greater value**.

If there are greater deviations, move the TELIMAT housing along the alphabetic scale:

- To **decrease** the spreading distance relative to the calibration chart setting: Move the TELIMAT on the alphabetic scale towards the **smaller character** (according to alphabetic order).
- To **increase** the spreading distance relative to the calibration chart setting: Move the TELIMAT on the alphabetic scale towards the **greater character** (according to alphabetic order).

#### NOTICE

#### Limited border spreading at working widths of 12 - 50m:

For an optimal spreading pattern, it is recommended that the application rate be reduced **by 20%** on the limited border spreading side.

### 7.10.3 Instructions for spreading with TELIMAT

The TELIMAT position required for the spreading type from the tractor is set by means of a single-acting control valve.

- Limited border spreading: lower position
- Normal spreading: upper position.

#### ▲ CAUTION



#### Spreading errors caused by the TELIMAT not reaching its end position

If the TELIMAT is not completely at its end position, you may encounter spreading errors.

- ▶ Make sure that the TELIMAT is always in the specified end position.
- ▶ When switching from boundary spreading to normal spreading, actuate the control valve until the TELIMAT is **completely** in the top end position.
- ▶ During extended boundary spreading (depending on the state of your operating unit), actuate the control valve occasionally to return the TELIMAT to its end position.

**NOTICE**

When older control equipment is used, leaks are possible during limited border spreading. In such case, the TELIMAT may leave the already reached end position (lower position) again. Therefore, return the TELIMAT to the end position at regular intervals in order to prevent spreading errors.

**Mechanical display of the spreading position**

The mechanical display of the spreading position is located directly at the right side of the TELIMAT relative to the direction of travel. The display can be seen from the driver's cab of the tractor.

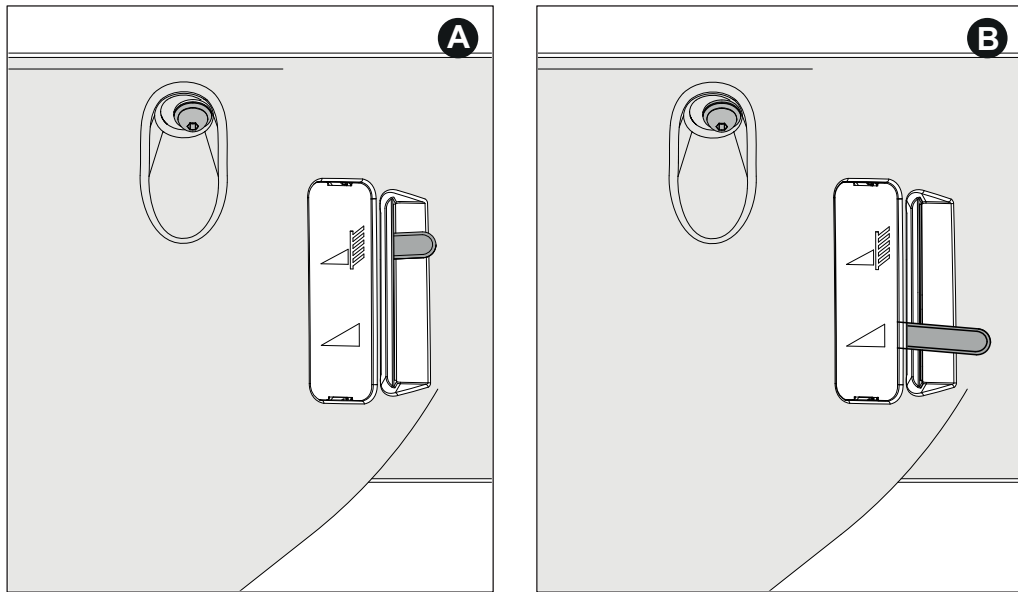

**Figure 7.21:** TELIMAT mechanical display

- [A] Limited border spreading position
- [B] Normal spreading position



## 7.11 Settings for unlisted fertiliser types

The settings for fertiliser types not listed in the fertiliser chart can be calculated using the practice test kit (optional equipment).

### NOTICE

For calculating the settings for unlisted fertiliser types, please also see the supplementary manual for the practice test kit.

To check the spreading unit settings **quickly**, we recommend the layout for **one passages**.

To determine the spreading unit settings **accurately**, we recommend the layout for **three passages**.

### 7.11.1 Requirements and conditions

### NOTICE

The requirements and conditions apply to both one passage and three passages. Observe these conditions to ensure that the results are as accurate as possible.

- Conduct the test on a **dry day, with no wind**, so the weather will not influence the result.
- We recommend a testing area that is horizontal in both directions. The tracks must **not** have any significant **cavities** or **heights** since this may distort the spreading pattern.
- Carry out the test either on freshly mown grass or on a field with low vegetation (max. 10 cm).

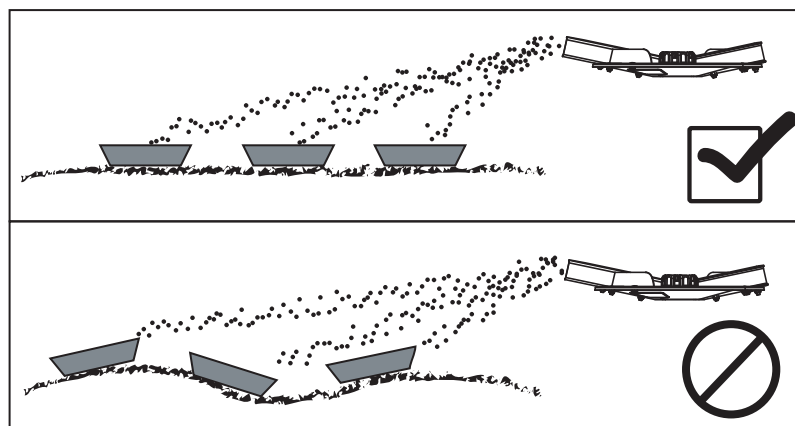

**Figure 7.22:** Layout of the collecting vessels

- Make sure that the collecting vessels are placed on level ground. Collecting vessels set at an angle can cause measuring errors (see image above).
- Running the calibration test (see [8.10: Calibration, page 87](#)).
- Adjust and lock the metering slides on the right and left-hand side (see [8.4: Adjusting the application rate, page 75](#)).

7.11.2 Running one passage

Layout:

**NOTICE**

We recommend the layout plan up to a spreading width of **24 m**. A layout plan for greater working widths is attached to the PPS5 practise test kit.

- Length of testing area: 60 to 70 m

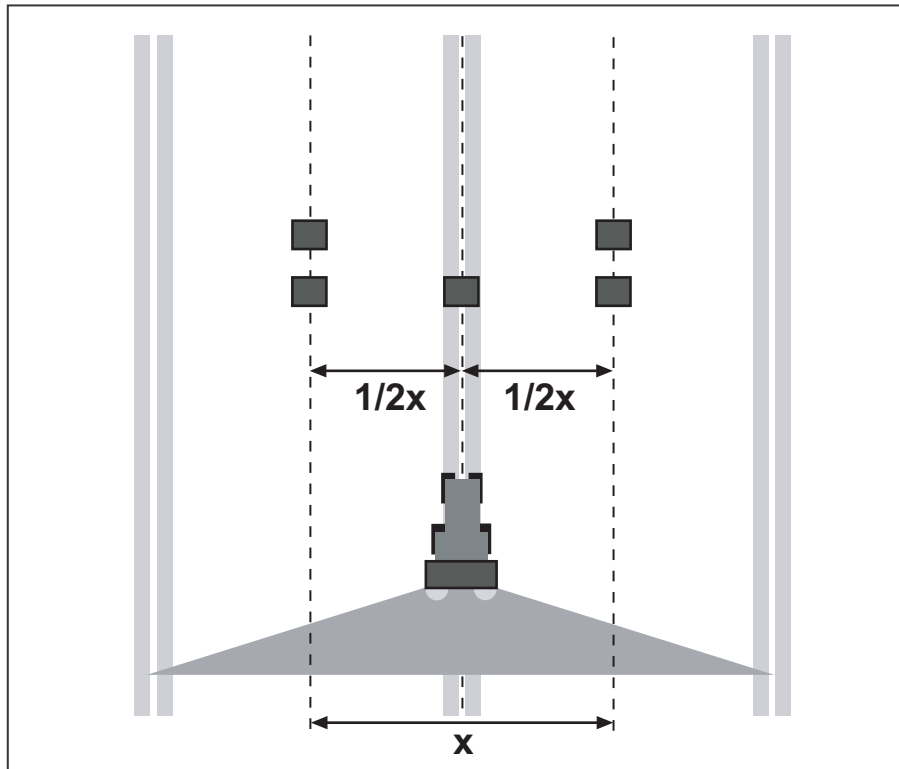

**Figure 7.23:** Layout for one passage

**Preparing one passage:**

- Choose a similar fertiliser from the fertiliser chart and adjust the spreader accordingly.
- Set the mounting height of the machine as specified in the fertiliser chart. Make sure that the mounting height includes the top edge of the trays.
- Check the spreading elements (spreading discs, spreader vanes, outlet) for correct functioning and completeness.
- Place two collecting vessels one after another at a distance of **1 m** in the overlap zones (between the tramlines) and one collecting vessel in the track (according to [figure 7.23](#)).

**Run the spreading test with the determined open position for operation:**

- Forward speed: **3 to 4 km/h**.
- Open the metering slide **10 m in front of** the collecting vessels.
- Close the metering slides approx. **30 m behind** the collecting vessels.

**NOTICE**

If the quantity collected in the collecting vessels is insufficient, repeat the passage.

Do not change the adjustment of the metering slides.

**7.11.3 Running three passages****Layout:****NOTICE**

We recommend the layout plan up to a spreading width of **24 m**. A layout plan for greater working widths is attached to the PPS5 practise test kit.

- Width of testing area: 3 x tramline distance
- Length of testing area: 60 to 70 m
- The three tracks must be parallel. If you are running the test without drilled tramlines, the paths must be measured using a tape measure and marked (e.g. with rods).

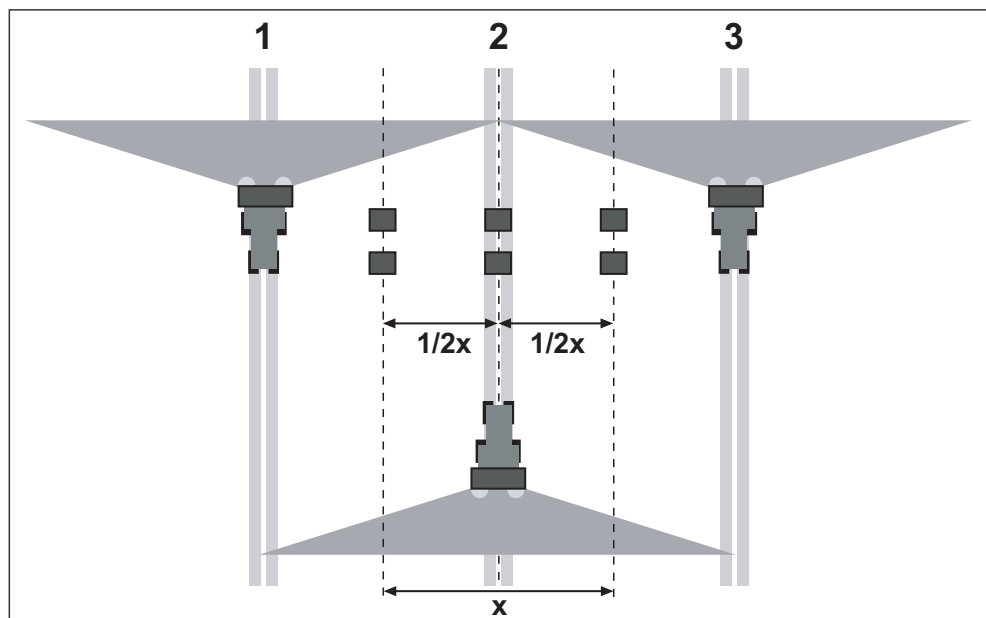

**Figure 7.24:** Layout for three passages

**Preparing three passages:**

- Choose a similar fertiliser from the fertiliser chart and adjust the spreader accordingly.
- Set the mounting height of the machine as specified in the fertiliser chart. Make sure that the mounting height includes the top edge of the trays.
- Check the spreading elements (spreading discs, spreader vanes, outlet) for correct functioning and completeness.
- Place two collecting vessels each, one after another, at a distance of **1 m** in the overlap zones and in the centre track (according to [figure 7.24](#)).

**Run the spreading test with the determined open position for operation:**

- Forward speed: **3 - 4 km/h**.
- Spread along the tramlines 1-3 one after the other.
- Open the metering slide **10 m in front of** the collecting vessels.
- Close the metering slides approx. **30 m behind** the collecting vessels.

**NOTICE**

If the quantity collected in the collecting vessels is insufficient, repeat the passage.  
Do not change the adjustment of the metering slides.

**7.11.4 Evaluate the results and correct if necessary**

- Pool the contents of the collecting vessels placed one after another and pour them into the measuring tubes from the left-hand side.
- The quality of the horizontal spreading pattern can be read off the three measuring tubes.

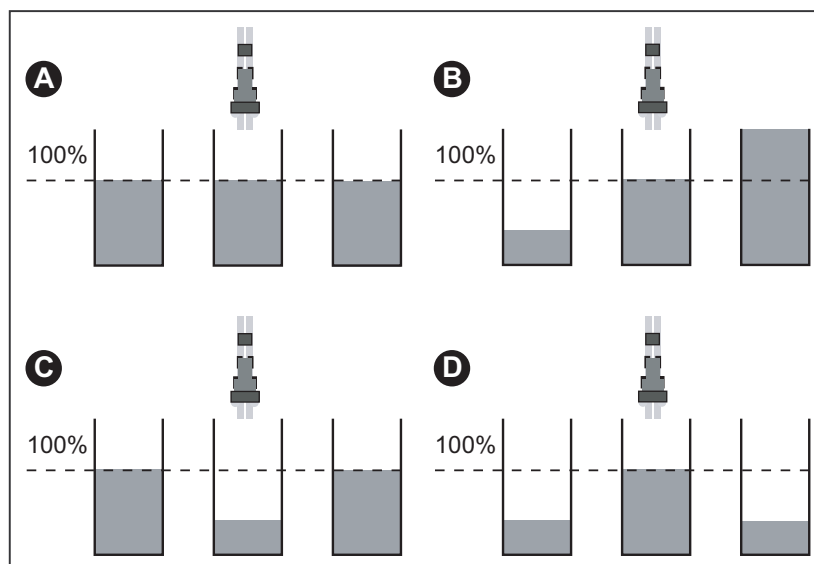

**Figure 7.25:** Possible results of pass

- [A] All tubes contain the same amount.
- [B] Asymmetrical fertiliser distribution
- [C] Too much fertiliser in the overlap zone
- [D] Too little fertiliser in the overlap zone

**Examples of spreader setting corrections:**

<b>Test re- sult</b>	<b>Fertiliser distribution</b>	<b>Action, test</b>
Case A	Even distribution (admissible deviation $\pm 1$ scale line)	Adjustments are correct.
Case B	Fertiliser quantity decreases from right to left (or vice versa).	Are the same drop points set on the right and left side?
		Is the metering slide setting on the left and right side the same?
		Tramline distances the same?
		Tramlines parallel?
		Was there a strong side wind during the test?
Case C	Too little fertiliser in the centre.	Select earlier drop point setting (e.g. change drop point from 5 to 4).
Case D	Too little fertiliser in the overlap zones.	Select later drop point setting (e.g. change drop point from 8 to 9).



## 8 Spreading operation

### 8.1 Safety

#### **⚠ DANGER**



#### **Danger of injury from running engine**

Working on the machine while the engine is running may result in serious injuries caused by mechanical components and escaping fertiliser.

- ▶ Wait until all rotating parts have come to a complete stop before making any adjustments.
- ▶ Switch the tractor motor off.
- ▶ Remove the ignition key.
- ▶ **Ensure that nobody is present in the hazard zone.**

**The following points should be noted before carrying out adjustments on the machine:**

- Always set the quantity while the metering slide is closed.

### 8.2 Instructions regarding the spreading operation

The intended use of the machine includes compliance with the operating, maintenance, and service conditions in accordance with the manufacturer specifications. **Spreading operation** therefore always includes **preparation** and **cleaning/maintenance**.

- Carry out spreading operations in accordance with the sequence described below.

#### Preparation

- Install the spreader at the tractor [Page 42](#)
- Close the metering slide
- Pre-set the mounting height [Page 47](#)
- Fill in the fertiliser [Page 53](#)
- Adjust the application rate [Page 75](#)
- Set the working width [Page 77](#)
  - Select the correct spreading disc
  - Adjust the drop point [Page 80](#)

---

#### Spreading

- Travel to the spreading location
- Check the mounting height
- Engage the PTO shaft
- Open the slider and start spreading
- Finish spreading operations, and close the slide
- Disengage the PTO shaft
- Discharge residual material [Page 95](#)

---

#### Cleaning/maintenance

- Open the metering slide
- Remove the spreader from the tractor
- Cleaning and maintenance [Page 101](#)



### 8.3 Using the fertiliser chart

#### NOTICE

Please observe chapter [7.8: Using the fertiliser chart, page 54](#).

### 8.4 Adjusting the application rate

#### 8.4.1 Version W/EMC (+ W)

#### NOTICE

The machine **versions W/EMC (+ W)** are equipped with an electric metering slide actuator application rate adjustment.

The electronic metering slide actuator is described in a separate operator's manual for the control unit. This operator's manual is an integral part of the operating unit.

#### ⚠ CAUTION



#### **Property damages caused by incorrect positioning of the metering slide**

If the stop levers are positioned incorrectly, the operation of the actuators via the electronic system (QUANTRON, ISOBUS) may cause damage to the metering slides.

- ▶ Always clamp the stop levers at the maximum scale position.

### 8.4.2 Version D

You can set the spreading quantity of the machines of the versions D via the lower scale arc on both openings.

For this purpose, move the pointer to the position specified beforehand in the fertiliser chart or from a calibration test. This is the **Open** stop position which the slide approaches hydraulically or by spring force (depending on the version) while spreading.

The position depends on the **application rate** and the **forward speed**.

1. Close the metering slide.
2. Determine the position for the scale setting in the fertiliser chart or based on the calibration test.
3. Release the setscrew [2] at the lower scale arc [3].
4. Move the pointer [1] of the stop to the determined position.
5. Tighten the setscrew.

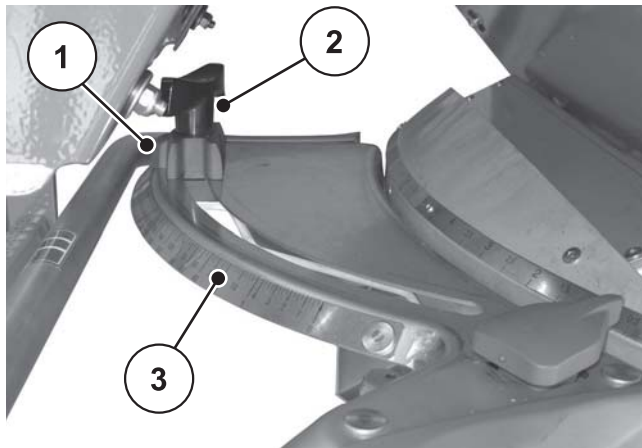

**Figure 8.1:** Scale for adjustment of the spreading quantity

- [1] Pointer stop
- [2] Setscrew
- [3] Lower scale curve

## 8.5 Setting the working width

### 8.5.1 Selecting the correct spreading disc

Various spreading discs are available for implementation of the working width depending on the fertiliser type.

Spreading disc type	Working width
S4	18-28 m
S6	24-36 m
S8	30-42 m
S10	32-48 m
S12	42-50 m

There are two different, permanently installed spreader vanes on every spreading disc. The spreader vanes are marked according to their model.

#### ▲ WARNING



#### Risk of injury from rotating spreading discs!

The distribution unit (spreading disc, vanes) may catch and pull-in body parts or objects. Contact with the distribution unit may injure, crush or cut off body parts.

- ▶ Maximum admissible mounting heights at front (V) and rear (H) are to be complied with at all times.
- ▶ Ensure that nobody is present in the hazard zone of the machine.
- ▶ Never remove deflectors mounted on the hopper.

Spreading disc type	Spreading disc left	Spreading disc right
S4	S4-L-200 S4-L-270	S4-R-200 S4-R-270
S4 VxR plus (coated)	S4-L-200 VxR S4-L-270 VxR	S4-R-200 VxR S4-R-270 VxR
S6 VxR plus (coated)	S6-L-255 VxR S6-L-360 VxR	S6-R-255 VxR S6-R-360 VxR
S8 VxR plus (coated)	S8-L-390 VxR S8-L-380 VxR	S8-R-390 VxR S8-R-380 VxR
S10 VxR plus (coated)	S10-L-340 VxR S10/S12-L-480 VxR	S10-R-340 VxR S10/S12-R-480 VxR
S12 VxR plus (coated)	S12-L-360 VxR S10/S12-L-480 VxR	S12-R-360 VxR S10/S12-R-480 VxR

8.5.2 Removing and mounting spreading discs

**⚠ DANGER**



**Danger of injury from running engine**

Working on the machine while the engine is running may result in serious injuries caused by mechanical components and escaping fertiliser.

- ▶ **Never** mount or dismount spreading discs while the engine is running or the PTO shaft of the tractor is rotating.
- ▶ Switch the tractor motor off.
- ▶ Remove the ignition key.

**Removing the spreading discs**

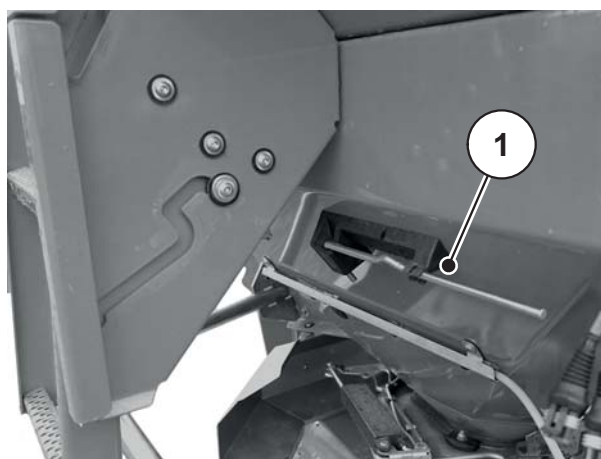

[1] Adjustment lever  
(hopper, left side according to  
direction of travel)

**Figure 8.2:** Adjustment lever

Proceed for both sides (left and right) as follows.



1. Remove the adjustment lever from the bracket.
2. Use the adjustment lever to loosen the cap nut of the spreading disc.

**Figure 8.3:** Loosen the cap nut

3. Unscrew the cap nut.
4. Remove the spreading disc from the hub.
5. Put the adjustment lever back into the specified bracket.



**Figure 8.4:** Unscrew the cap nut

### Mounting the spreading discs

#### Requirements:

- PTO and tractor engine are switched off and locked to prevent unauthorised starting.

Mount the left spreading disc on the left side in the direction of travel and the right spreading disc on the right side in the direction of travel. Make sure that the left and right spreading discs are not reversed.

The following procedure is for mounting the left-hand spreading disc. Mount the right-hand spreading disc according to these instructions as well.

1. Put the left spreading disc onto the left spreading disc hub.

The spreading disc must be evenly placed on the hub (if required, remove dirt).

#### **NOTICE**

The pins on the spreading disc holders have different positions on the left and right side. The correct spreading disc is the one that fits precisely into the spreading disc holder.

2. Carefully position the cap nut (do not tilt).
3. Tighten the cap nut with approx. 38 Nm.

#### **NOTICE**

The cap nuts have an internal catching mechanism that prevents them from coming loose. The catching mechanism must be noticeable while tightening, otherwise, the cap nut is worn and must be replaced.

4. Check that there is clearance between the spreader vanes and the outlet by turning the spreading discs by hand.

### 8.5.3 Adjusting the drop point

#### AXIS 50.2 D

With selection of the spreading disc type, a particular range for the working width is defined. By altering the drop point, the working width can be accurately set and adjustments to different fertiliser types can be made.

The drop point is set using the top scale plate.

- Adjusting in the direction of smaller numbers: The fertiliser is ejected sooner. This results in spreading patterns for smaller working widths.
- Adjusting in the direction of larger numbers: The fertiliser is ejected later and spread more towards the outside into the overlap zones. This results in spreading patterns for larger working widths.

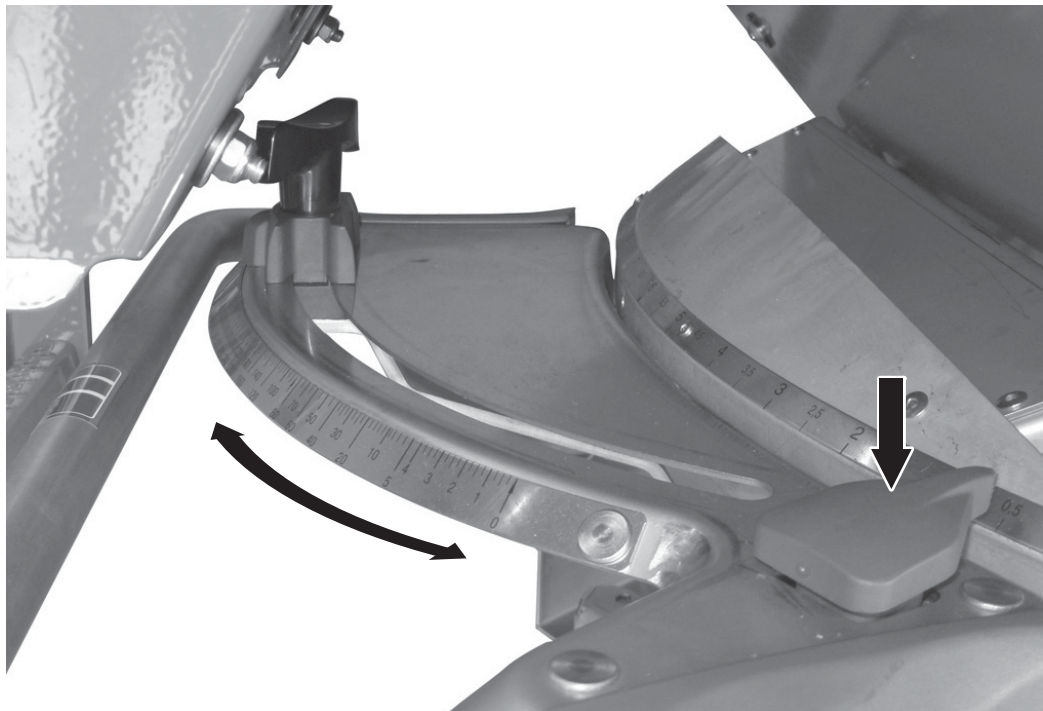

**Figure 8.5:** Adjustment centre for drop point

1. Determine the position for the drop point in the fertiliser chart or by carrying out a test using the practice test kit (optional equipment).
2. Grip the left and right handle.
3. Press the pointer unit.
  - ▷ The lock is released. The adjustment centre can be moved.
4. Move the adjustment centre with the pointer to the calculated position.
5. Release the pointer unit.
  - ▷ The adjustment centre is locked.
6. Ensure that the adjustment centre is locked.

**AXIS 50.2 W****NOTICE**

The machine version W is equipped with an electronic drop point adjustment.

The electronic drop point adjustment is described in a separate operating manual for the operating unit. This operator's manual is an integral part of the operating unit.

With the selection of the spreading disc type, you can specify a particular range for the working width. By altering the drop point, the working width can be accurately set and adjustments to different fertiliser types can be made.

You can set the drop point via the upper scale arc.

- Adjusting in the direction of smaller numbers: The fertiliser is ejected sooner. This results in spreading patterns for smaller working widths.
- Adjusting in the direction of larger numbers: The fertiliser is ejected later and spread more towards the outside into the overlap zones. This results in spreading patterns for larger working widths.



**Figure 8.6:** Drop point gauge

### 8.6 Checking the mounting height

#### **NOTICE**

Check if the preset mounting height is correct while the hopper is full.

- Take the mounting height setting values from the fertiliser chart.
  - Observe the maximum admissible mounting height.
  - See also ["Presetting the mounting height" on page 47](#).
- 

### 8.7 Setting the PTO speed

#### **NOTICE**

Take the correct PTO speed from the fertiliser chart.

---



## 8.8 Spreading at the headlands

In order to achieve a good fertiliser distribution at the headlands, a precise arrangement of the tramlines is essential.

### Limited border spreading

Spreading at the headlands with the remote-controlled TELIMAT limited border spreading system:

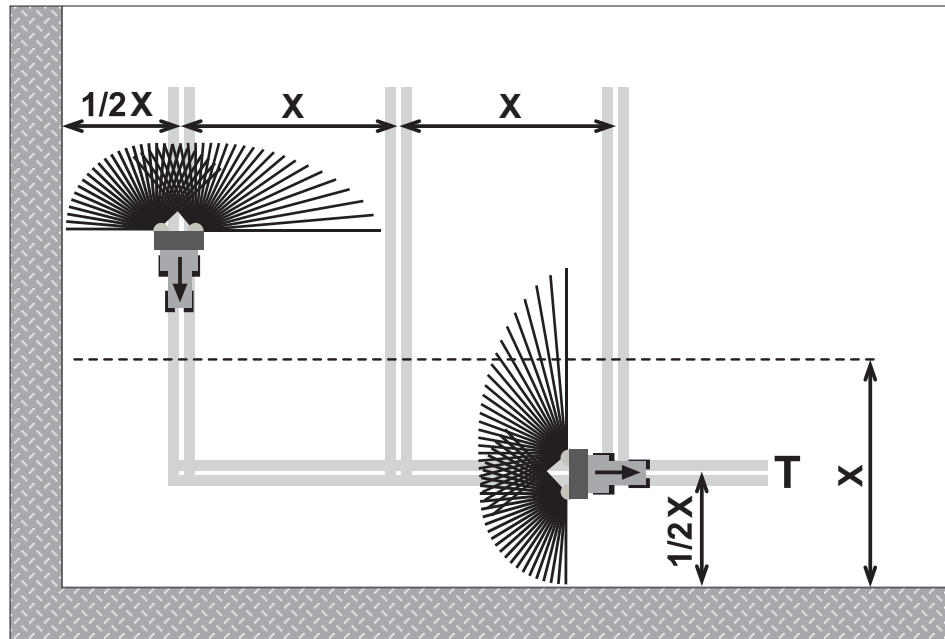

**Figure 8.7:** Limited border spreading

[T] Headlands tramline  
[X] Working width

- Place the headlands tramline [T] at a distance of half the working width [X] from the edge of the field.

### Normal spreading in or out of the headlands tramline

#### NOTICE

If you use a GPS System (e.g. QUANTRON guide) as well as the operating unit QUANTRON-E2 and/or QUANTRON-A for operating your machine, check that the software of the operating unit includes the **OptiPoint** function.

The **OptiPoint** function by RAUCH calculates the optimal switching-on and switching-off point for spreading in the headline based on the settings in the operating unit.

- You can skip the information in the present paragraph since the **OptiPoint** function assumes these settings.
- Please observe the operator's manual for the corresponding control unit.

If you continue spreading in the field after headlands tramline spreading:

- Move the border spreading unit TELIMAT out of the spreading area.

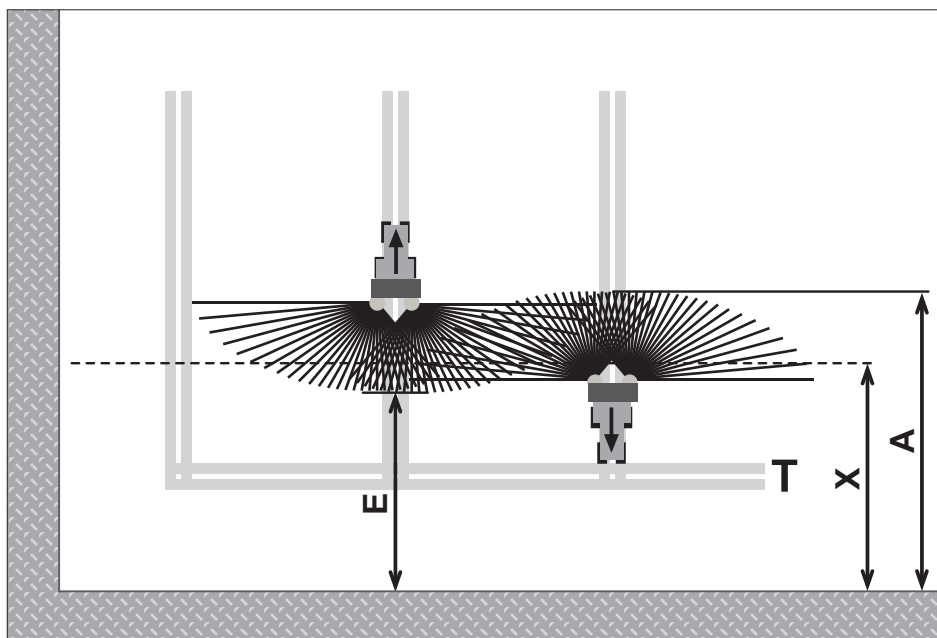

**Figure 8.8:** Normal spreading

- [A] End of spreading fan when spreading in the headlands tramline
- [E] End of spreading fan when spreading in the field
- [T] Headlands tramline
- [X] Working width

The metering slides open or close at different distances to the field border of the headlands when travelling backwards and forwards.

**Driving out of the headlands tramline**

- **Open** the metering slides if the following requirement is met:
  - The end of the spreading fan on the field [E] is at approx. half of the working width + 4 to 8 m from the field boundary of the headlands.

The tractor is then located at different distances in the field, depending on the spreading distance of the fertiliser.

**Driving into the headlands tramline**

- Close the metering slides **as late as possible**.
  - The end of the spreading fan should ideally lie on the field [A] at a distance of approx. 4 to 8 m further than the working width [X] of the headlands.
  - This cannot always be achieved, depending on the spreading distance of the fertiliser and the working width.
- Alternatively, drive beyond the headlands tramline, or lay out a 2nd headlands tramline.

Follow these instructions in order to ensure an environmentally friendly and economical working method.

**8.9 Spreading with section control (VariSpread)**

With the spreading width assistant VariSpread, you can reduce the spreading width and the application rate on each side. You can spread on wedge-shaped fields with high precision.

**NOTICE**

Some models are not available in all countries.

Version	VariSpread V2	VariSpread V4 QUANTRON-A	VariSpread Pro ISOBUS
	1 section on each side	2 sections on each side	continuous section control
D	●		
W		●	
EMC (+ W)			●

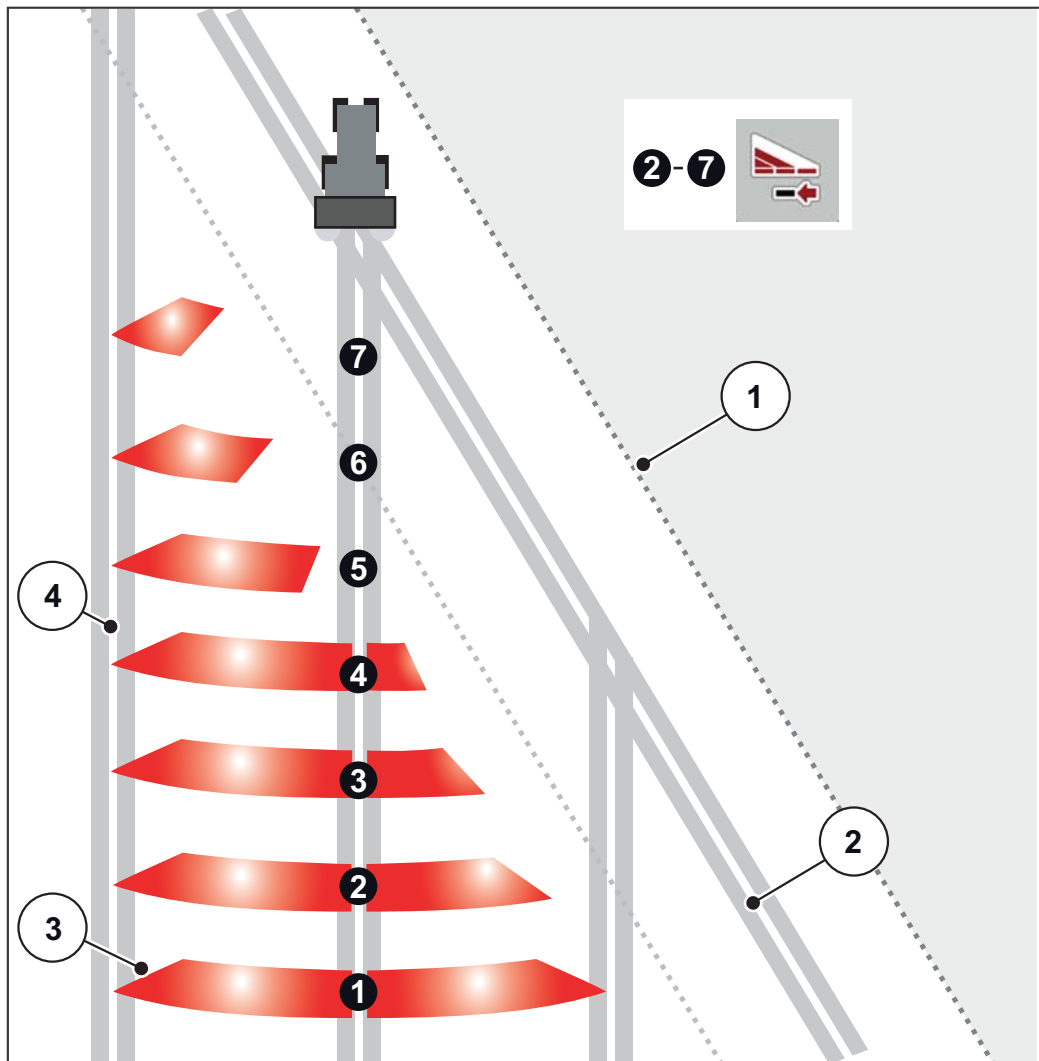

**Figure 8.9:** Section control example with VariSpread Pro

- [1] Field edge
- [2] Sections 1 to 4: successive section width reduction on the right
- [3] Tractor track

**NOTICE**

The VariSpread compatible machine is equipped with two electrical drop point actuators. Via the QUANTRON-A control unit or with the ISOBUS machine control unit, you can specify the settings of the sections and achieve accurate spreading operation results in wedge-shaped fields.

- More detailed information about possible settings of the sections is provided in the operator's manual of your ISOBUS machine control unit.

## 8.10 Calibration

### NOTICE

The machine of the **M EMC** version automatically regulates the application rate for each side. Therefore, a calibration test is **not required**.

### NOTICE

Execute the calibration test for the machine versions **W** at the control unit.

The calibration test is described in a separate operator's manual for the control unit. This operator's manual is an integral part of the control unit.

For precise control of the application rate, we recommend running a new calibration test every time you change fertiliser material types.

Carry out calibration:

- Before spreading for the first time.
- If the fertiliser quality has changed significantly (moisture, high dust content, cracked grain).
- If a new fertiliser type is used.

The calibration must be conducted with engaged PTO at a standstill or during travel over a test track.

### 8.10.1 Determining the nominal output quantity

Calculate the nominal output quantity before starting the calibration test.

#### Calculating the exact forward speed

The exact forward speed must be known to calculate the nominal output volume.

1. With a **semi-filled** machine, drive a distance of **100 m on the field**.
2. Stop the time required for this.
3. The exact forward speed is indicated at the scale of the calibration test calculator.

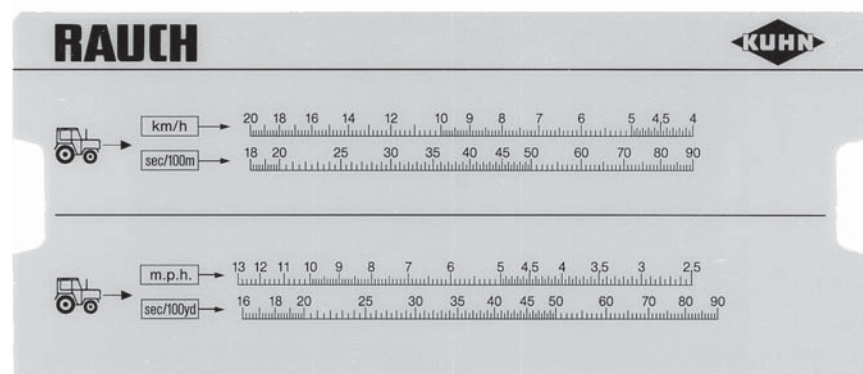

Figure 8.10: Scale for calculating the exact forward speed

The exact forward speed can also be calculated using the following formula:

$$\text{Forward speed (km/h)} = \frac{360}{\text{Stopped time on 100m}}$$

**Example:** You need 45 seconds for 100 m:

$$\frac{360}{45 \text{ sec}} = 8 \text{ km/h}$$

**Determining the nominal output quantity per minute**

To calculate the nominal output quantity per minute, you will require the following:

- The exact forward speed,
- the working width,
- the desired application rate.

**Example:** You wish to calculate the nominal output quantity at a particular outlet. Your forward speed is **8 km/h**, the working width is specified to be **18 m** and the application rate shall amount to **300 kg/ha**.

**NOTICE**

For some application rates and forward speeds, the output quantity is already shown in the fertiliser chart.

If you cannot find your values in the fertiliser chart, they can be determined with the calibration test calculator or with a formula.

**Calculation with the calibration test calculator:**

1. Move the tab until it is at 300 kg/ha under 18 m.
  2. The value of the nominal output quantity for both outlets can now be read off above the value of the forward speed of 8 km/h.
- ▷ **The nominal output quantity per minute amounts to 72 kg/min.**
- If you implement the calibration at one output only, halve the total value of the nominal output quantity.
3. Divide the read off value by 2 (= number of outlets).
- ▷ **The nominal output quantity per output amounts to 36 kg/min.**

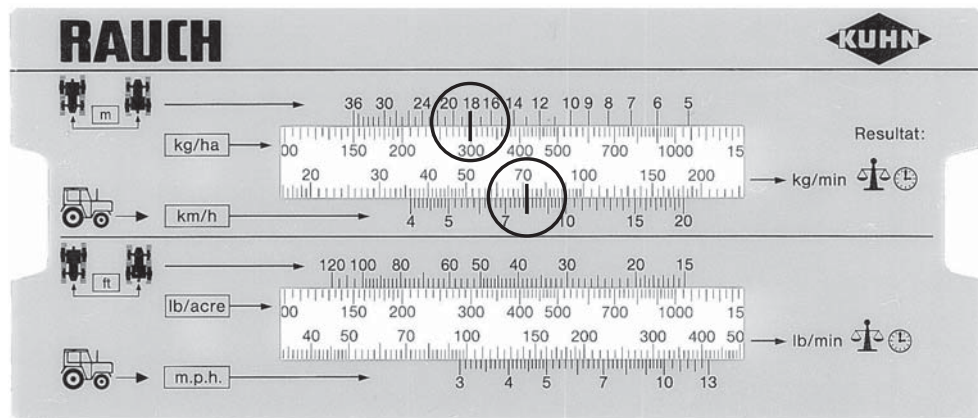

**Figure 8.11:** Scale for calculation of the nominal output quantity per minute

**Calculation with formula**

The nominal output quantity can also be calculated using the following formula:

$$\text{Nominal output quantity (kg/min)} = \frac{\text{Forward speed (km/h)} \times \text{Working width (m)} \times \text{Application rate (kg/ha)}}{600}$$

Calculation for example:

$$\frac{8 \text{ km/h} \times 18 \text{ m} \times 300 \text{ kg/ha}}{600} = 72 \text{ kg/min}$$

**NOTICE**

Constant fertiliser application is only possible at an even forward speed.

Example: a 10 % increased speed results in 10 % underfertilisation.

### 8.10.2 Implementing the calibration

**⚠ WARNING**



**Risk of injury due to chemicals**

Escaping fertiliser may lead to injury to eyes and nasal mucous membrane.

- ▶ Wear safety goggles during the calibration.
- ▶ Before running the calibration test, ensure that all people leave the hazard zone of the machine.

---

**Requirements:**

- The metering slides are closed.
- PTO and tractor engine are switched off and locked to prevent unauthorised starting.
- An adequately sized hopper is ready for collecting the fertiliser (minimum capacity **25 kg**).
  - Determine the empty weight of the collecting vessel.
- Prepare the calibration test chute. The calibration test chute is located in the centre behind the spreading disc guard.
- A sufficient quantity of fertiliser is placed in the hopper.
- The preliminary settings for the metering slide stop, the PTO speed and the calibration test time are specified and known from the fertiliser charts.

**NOTICE**

Select the values for the calibration test in a way that the largest quantities of fertiliser possible are calibrated. The higher the quantity, the higher the precision of the measurement.

---

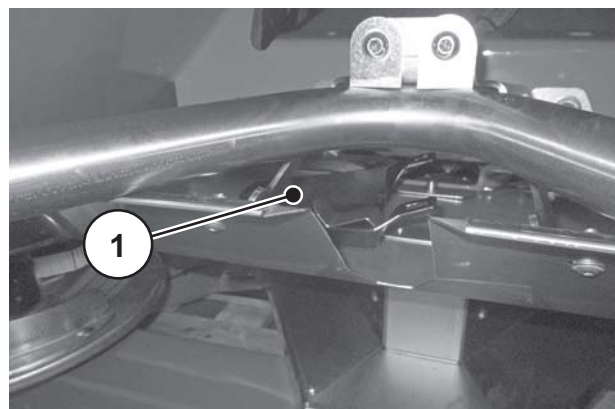

[1] Position of the calibration test chute

**Figure 8.12:** Calibration test chute



Implementation (example on the left side of the spreader):

**NOTICE**

The calibration has to be carried out at **one** side of the machine only. For safety reasons, however, **both** spreading discs must be removed.

1. Use the adjustment lever to loosen the cap nut of the spreading disc.
2. Remove the spreading disc from the hub.



**Figure 8.13:** Loosen cap nut

3. Set the drop point to position 0.



**Figure 8.14:** Attach the calibration test chute

4. Suspend the calibration test chute under the left outlet (in the direction of travel).

5. Set the metering slide stop end to the scale value from the fertiliser chart.

**⚠ WARNING**



**Risk of injury due to rotating machine components**

Rotating machine components (universal drive shaft, hubs) may catch and pull-in body parts or objects. Contact with rotating machine components may cause bruises, abrasions and crushing injuries.

- ▶ Always stay outside the area of rotating hubs while the machine is running.
- ▶ When the drive shaft is rotating, the metering slides are to be operated from the tractor seat **at all times**.
- ▶ Ensure that nobody is present in the hazard zone of the machine.

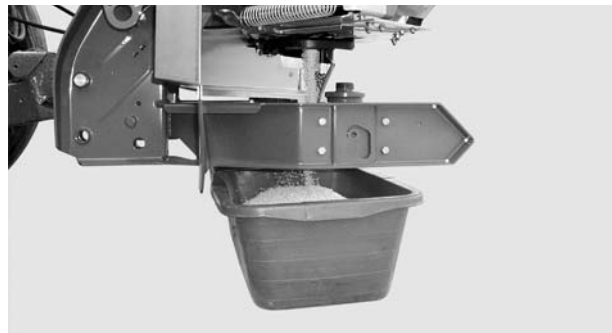

6. Position a collection vessel under the left outlet.

**Figure 8.15:** Implement the calibration test

7. Start the tractor.
8. Set the PTO speed according to the values in the fertiliser chart.
9. Open the left metering slide for the calibration test time stipulated before from the tractor seat.
10. Close the metering slide when this time has elapsed.
11. Determine the fertiliser weight (taking into consideration the empty weight of the collection vessel).
12. Compare the actual quantity with the target quantity.
  - ▷ Actual output volume = target outlet volume: application rate stop/stopper is set correctly. End calibration test.
  - ▷ Actual outlet volume < target outlet volume: Set the application rate stop/stopper to a higher position and repeat the calibration test.
  - ▷ Actual outlet volume > target outlet volume: Set the application rate stop/stopper to a lower position and repeat the calibration test.

**NOTICE**

You can use the percentage scale to reset the position of the application rate stop/stopper. For example, if the calibration test weight is down by 10%, the application rate stop/stopper is set to a 10% higher position (e.g. from 150 to 165).

Calculation with formula

The position of the application rate stop/stopper can also be calculated using the following formula:

New position of the output- rate stop	=	Position of the application rate stop/stopper during current calibra- tion test	x	Target outlet volume
		----- Actual outlet volume during the current calibration test		

13. End calibration test. Switch off the PTO shaft and tractor engine and lock them to prevent unauthorised starting.
14. Mount the spreading discs. Make sure that the left and right spreading discs are not reversed.

### NOTICE

The pins on the spreading disc holders have different positions on the left and right side. The correct spreading disc is the one that fits precisely into the spreading disc holder.

15. Carefully position the cap nut (do not tilt).
16. Tighten the cap nut with approx. **38 Nm**. Do **not** use the adjustment lever.



**Figure 8.16:** Screw on the cap nut

**NOTICE**

The cap nuts have an internal catching mechanism that prevents them from coming loose. The catching mechanism must be noticeable while tightening the nut. Otherwise, the cap nut is worn and must be replaced.

---

17. Check that there is clearance between the spreader vanes and the outlet by turning the spreading discs by hand.
18. Re-mount the calibration test chute and the adjustment lever at their specified locations at the machine.
19. **Important information:** Reset the drop point to the determined spreading position.

## 8.11 Discharging residual material

### ▲ WARNING



#### Risk of injury due to rotating machine components

Rotating machine components (universal drive shaft, hubs) may catch and pull-in body parts or objects. Contact with rotating machine components may cause bruises, abrasions and crushing injuries.

- ▶ Always stay outside the area of rotating hubs while the machine is running.
- ▶ When the drive shaft is rotating, the metering slides are to be operated from the tractor seat **at all times**.
- ▶ Ensure that nobody is present in the hazard zone of the machine.

To maintain the value of your machine, discharge the hopper immediately after every use. Proceed as with the calibration test to discharge the residue.



- Set the drop point to position 0.

#### Instructions for completely discharging the residual material:

Small amounts of fertiliser may remain in the machine when discharging residual material normally. If you wish to discharge the residual material completely (e.g. at the end of the spreading season, when changing spreading material), please proceed as follows:

1. Empty the hopper until no more spreading material comes out (normal discharge of residual material).
2. Switch off the PTO and the tractor engine and lock them to prevent unauthorised starting. Remove the ignition key of the tractor.
3. While the metering slide is open, move the drop point back and forth (position 0 to 9 and back).
4. Remaining fertiliser can be removed with a soft water jet when cleaning the machine; [See also "Cleaning" on page -111](#)

## 8.12 Parking and decoupling the machine

The machine can be securely parked on the frame or the stabilising rollers (optional equipment).

### **⚠ DANGER**



#### **Crushing hazard between the tractor and the machine**

Persons standing between the tractor and the machine while they are being parked or unhitched are in lethal danger.

- ▶ Ensure that nobody is present in the hazard zone between the tractor and the machine.

#### **Requirements for parking the machine:**

- Only park the machine on level, solid ground.
- Only park the machine when the hopper is empty.
- Relieve the load on the coupling points (lower / upper link) before removing the machine.
- After unhitching, place the universal drive shaft, hydraulic hoses, and electric cables in the retainers provided for the purpose.

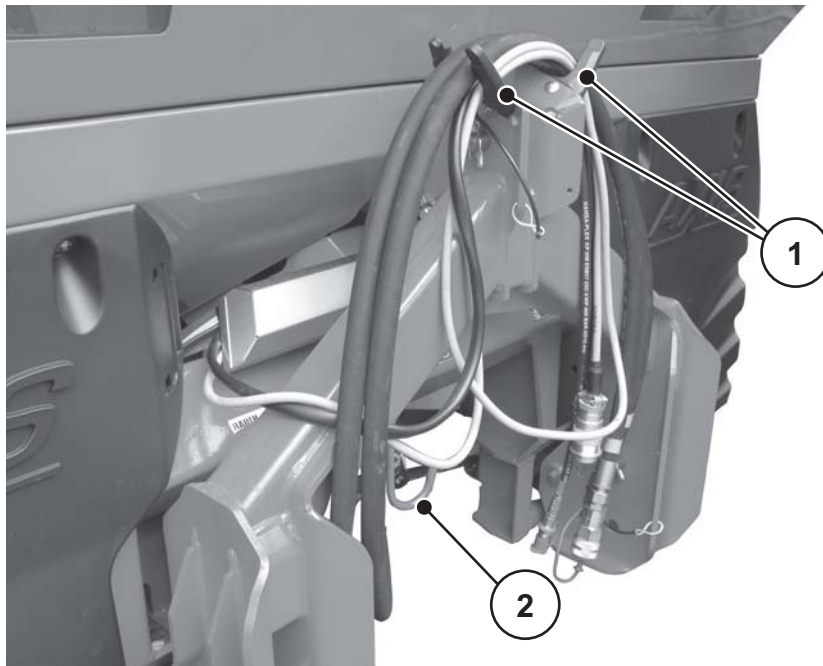

**Figure 8.17:** Storage of the cables and hydraulic hoses

- [1] Bracket for hoses and cables
- [2] Universal drive shaft bracket

5. Open metering slides.
6. Uncouple the hydraulic hoses.

## 9 Faults and possible causes

### ▲ WARNUNG



#### Risk of injury when rectifying faults inappropriately

Delayed or incorrect repairs by unqualified personnel may result in severe personal injury as well as in damages to the machine and the environment.

- ▶ Any faults occurring must be repaired **immediately**.
- ▶ Only carry out repairs yourself if you have the appropriate **qualifications**.

#### Troubleshooting requirements

- Switch off the PTO and the tractor engine and lock them to prevent unauthorised starting.
- Put down the machine on the ground.

### HINWEIS

Please take particular note of the warnings in chapters [3: Safety, page 5](#) and [10: Maintenance and service, page 101](#) before correcting any faults.

Fault	Possible cause	Measure
Uneven fertiliser distribution	● Clumps of fertiliser on spreading discs, spreading vanes and outlet ducts.	● Remove the clumps of fertiliser.
	● Metering slides do not open completely.	● Check the function of opening slides.
	● Drop point incorrectly adjusted.	● Correct the drop point adjustment.
Too much fertiliser in the tractor track	● Defective spreading vanes, outlets.	● Replace defective parts immediately.
	● The fertiliser has a smoother surface than the fertiliser that was tested for the fertiliser chart.	● Select later drop point setting (e.g. from 4 to 5).
	● PTO speed too low.	● Correct RPM.
Too much fertiliser in the overlap area	● The fertiliser has a rougher surface than the fertiliser that was tested for the fertiliser chart.	● Select earlier drop point setting (e.g. from 5 to 4).
	● PTO speed too high.	● Correct RPM.

Fault	Possible cause	Measure
<p>Spreader application higher on one side than the other.</p> <p>Hopper empties unevenly during normal spreading.</p>	Fertiliser bridging above the agitator	<ul style="list-style-type: none"> <li>● Remove fertiliser until the height of the protective grid on the affected side.</li> <li>● Break up accumulated fertiliser with a wooden stick through the bars of the protective grid.</li> </ul>
	Outlet blocked	<ul style="list-style-type: none"> <li>● See blockages of the metering openings</li> </ul>
	Metering slide set incorrectly	<ul style="list-style-type: none"> <li>● Empty the hopper of remaining fertiliser.</li> <li>● Check metering slide setting. Refer to the chapter on maintenance</li> </ul>
	Defective agitator	<ul style="list-style-type: none"> <li>● Remove fertiliser until the height of the protective grid on the affected side.</li> <li>● Open the metering slide and break up accumulated fertiliser with a wooden stick through the bars of the protective grid so that the remaining fertiliser can run out of the outlet.</li> <li>● Check the functionality of the agitator drive. See <a href="#">chapter 10.8: Checking the agitator drive, page 113</a></li> </ul>



Fault	Possible cause	Measure
Irregular fertiliser feed to spreading disc	Fertiliser bridging above the agitator	<ul style="list-style-type: none"> <li>● Remove fertiliser until the height of the protective grid on the affected side.</li> <li>● Break up accumulated fertiliser with a wooden stick through the bars of the protective grid.</li> </ul>
	Outlet blocked	<ul style="list-style-type: none"> <li>● See blockages of the metering openings</li> </ul>
	Defective agitator	<ul style="list-style-type: none"> <li>● Remove fertiliser until the height of the protective grid on the affected side.</li> <li>● Open the metering slide and break up accumulated fertiliser with a wooden stick through the bars of the protective grid so that the remaining fertiliser can run out of the outlet.</li> <li>● Check the functionality of the agitator drive. See <a href="#">chapter 10.8: Checking the agitator drive, page 113</a>.</li> </ul>
Spreading discs are fluttering.		<ul style="list-style-type: none"> <li>● Check cap nuts for tight fit and check threads.</li> </ul>
Metering slide does not open	<ul style="list-style-type: none"> <li>● Metering slides do not move easily.</li> </ul>	<ul style="list-style-type: none"> <li>● Check for smooth movement of the slide, the lever and the joints, and improve if necessary.</li> <li>● Check the extension spring.</li> </ul>
	<ul style="list-style-type: none"> <li>● The reducing plate at the hose connection of the plug-in connector is contaminated.</li> </ul>	<ul style="list-style-type: none"> <li>● Clean the reducing plate at the hose connection of the plug-in connector.</li> </ul>
The metering slide opens too slowly.		<ul style="list-style-type: none"> <li>● Clean the restrictor plate.</li> <li>● Replace the 0.7mm restrictor plate with a 1.0mm restrictor plate. The plate is located at the hose connection of the plug-in connector.</li> </ul>
Agitator not working.	The agitator drive is defective.	<ul style="list-style-type: none"> <li>● Check the agitator drive. See <a href="#">10.8: Checking the agitator drive, page 113</a></li> </ul>

## 9 Faults and possible causes

Fault	Possible cause	Measure
<p>Blockage of the metering openings due to: Fertiliser clumps, damp fertiliser, miscellaneous impurities (leaves, straw, sack residues)</p>	<ul style="list-style-type: none"> <li>● Clogging</li> </ul>	<ol style="list-style-type: none"> <li>1. Park tractor, remove ignition key, disconnect the power supply,</li> <li>2. Open metering slide.</li> <li>3. Place collecting vessel underneath.</li> <li>4. Remove spreading discs.</li> <li>5. Clean the outlet <b>from below</b> with a wooden pole or the adjustment lever and push through the metering opening.</li> <li>6. Remove any foreign objects in the hopper.</li> <li>7. Install spreading discs, close metering slides.</li> </ol>
<p>The spreading discs do not turn or stop suddenly after being turned on.</p>	<p>When using a transmission with shear bolt clutch</p> <ul style="list-style-type: none"> <li>● The shear pin is defective.</li> </ul>	<ul style="list-style-type: none"> <li>● Check the shear pin protection, and replace if necessary (see the universal drive shaft manufacturer's manual).</li> </ul>

## 10 Maintenance and service

### 10.1 Safety

#### NOTICE

Please note the warnings in chapter [3: Safety, page 5](#).

Take **particular note of the instructions** in the section [3.8: Maintenance and repair, page 11](#).

Maintenance and service work involves additional hazards that do not occur during operation of the machine.

For this reason, any maintenance and repair work is to be conducted with increased alertness at all times. Work particularly thoroughly and cautiously.

Observe the following instructions in particular:

- Welding and work on the electrical and hydraulic systems is to be carried out by qualified technicians only.
- There is a **risk of tipping** when working at the lifted machine. Always secure the machine using suitable supports.
- Always use **both** eyebolts in the hopper for lifting the machine with hoisting gear.
- There is a **risk of crushing and shearing at power-operated components (adjustment lever, metering slide)**. Make sure that there is no one in close proximity to the moving parts during maintenance.
- Spare parts must at least comply with the technical standards specified by the manufacturer. This is assured only with original spare parts.
- Before starting any cleaning, maintenance, or repair work, and when troubleshooting, switch off the tractor's engine and wait until all moving parts of the machine have come to a stop.
- By controlling the machine with an operating unit, additional risks and hazards due to externally operated components may arise.
  - Disconnect the power supply between the tractor and the machine.
  - Disconnect the power supply cable from the battery.
- **ONLY an instructed and authorised workshop** may carry out any repair work.

### 10.2 Using the steps

#### 10.2.1 Safety

Always keep in mind that troubleshooting involves additional hazards in case you are climbing into the hopper.

Use the steps with extra care. Work particularly thoroughly and cautiously.

Observe the following instructions in particular:

- Turn the tractor motor off and wait until all moving parts have stopped moving. Take the ignition key out.
- Only use the steps when the machine is lowered.
- Only use the steps if they are folded out.
- Do not climb over the hopper cover into the hopper.
- Use the handle on the hopper cover.
- Only climb into the empty hopper.

#### DANGER



#### Risk of injury due to moving parts in the hopper

There are moving parts in the hopper.

The rotating agitator can cause injury to hands and feet.

- ▶ Turn off the agitator.
- ▶ Climb into the hopper **only** for troubleshooting purposes.
- ▶ The protective grid may **only** be opened for maintenance purposes or in the event of a fault.

#### 10.2.2 Folding out the steps

Before folding out the steps:

- Disengage the PTO shaft.
- Turn the tractor motor off.
- Lower the fertiliser spreader.

Please follow the following instructions for folding out steps.

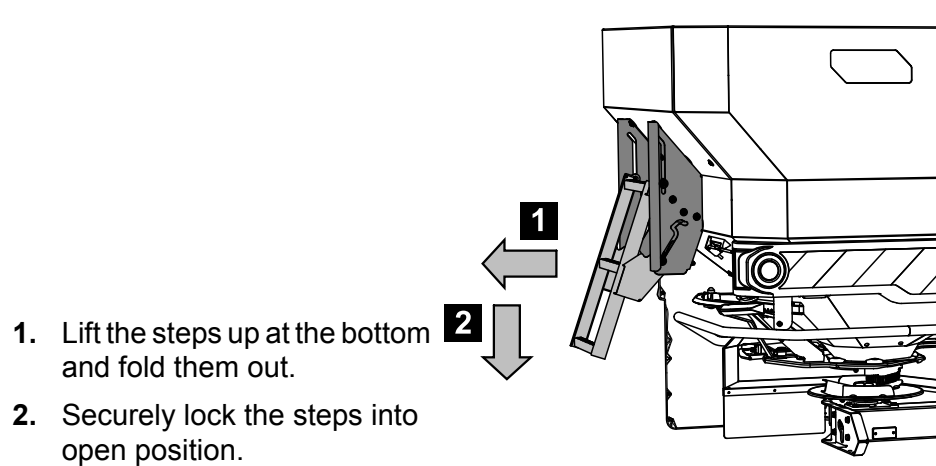
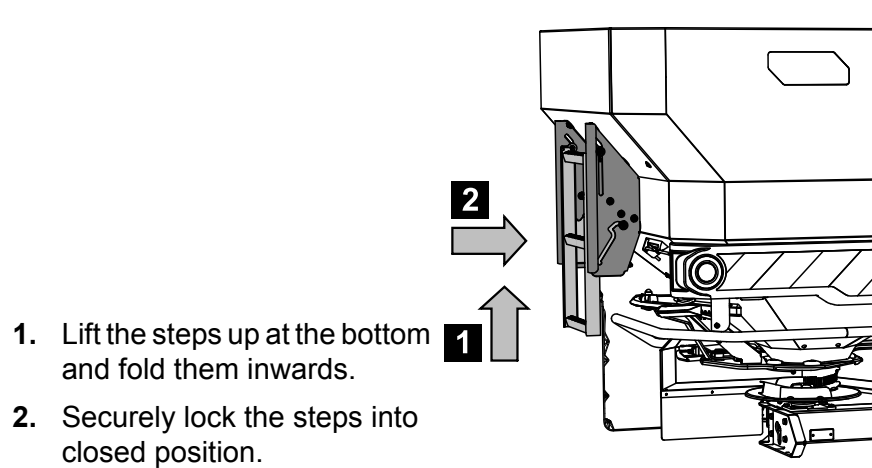

**Figure 10.1:** Folding out the steps

### 10.2.3 Folding in the steps

Before every trip and during spreading operation:

- Fold in the steps.

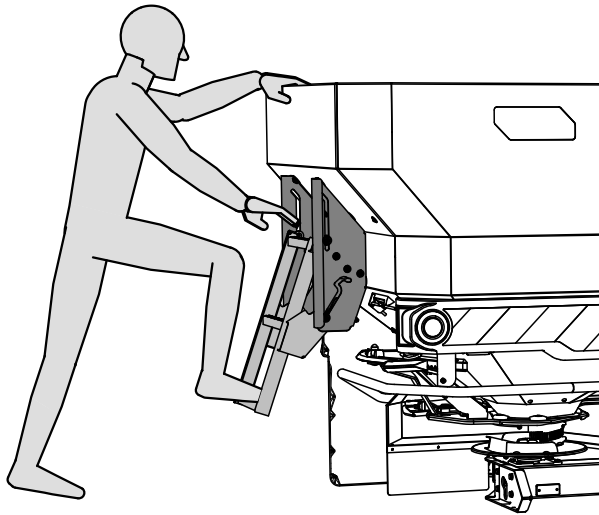

**Figure 10.2:** Folding in the steps in closed position

### 10.2.4 Using the steps securely

Use hand grips when climbing onto the machine.

- Only use latched and folded-out steps.
- Without hopper cover on machine, use the side wall of the hopper as hand grip in order to securely climb onto the machine.
- If the machine is equipped with a hopper cover, use the hand grip on the hopper cover in order to securely climb onto the machine.



**Figure 10.3:** Climbing onto the machine without hopper cover

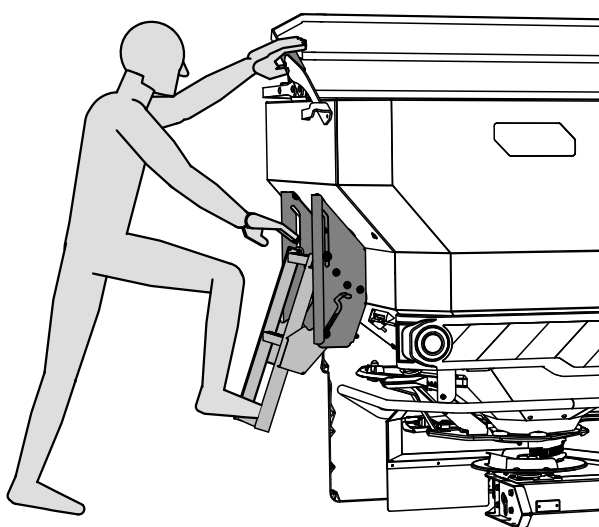

**Figure 10.4:** Climbing onto the machine with hopper cover

### 10.3 Wear parts and screw connections

#### 10.3.1 Checking wear-prone parts

Wear-prone parts are: **spreader vanes, agitator head, outlet, hydraulic hoses** and all plastic parts.

Plastic parts are subject to a certain ageing process even under normal spreading conditions. Plastic parts are e.g. **protective grid locks, connecting rod**.

- Inspect wear parts regularly.

Replace these parts if they show signs of wear, deformation, holes or ageing. Otherwise, the spreading pattern will not be correct.

The durability of wear parts depends, among other things, on the material being spread.

#### 10.3.2 Checking screw connections

Screw connections have been tightened to the specified torque and locked at the factory. Vibrations and shocks, in particular during the initial operating hours, can loosen bolted joints.

- With new machines, all screw connections are to be checked for their tight seat after approx. 30 operating hours.
- Check all the bolted joints regularly for tightness, and definitely before the start of the spreading season.

Some components (e.g. spreader vanes) are mounted with self-locking nuts. When mounting these components always use new self-locking nuts.

### 10.3.3 Checking the screw connections of the weigh cells (version W)

The machine is equipped with 2 weigh cells and a tie rod. These elements are fixed by means of screw connections.

Check the screw connections for the weigh cells and the tie rod for tightness on both sides of the machine:

- before every spreading season
- also during the spreading season if necessary.

#### Checking:

1. Tighten the screw connection with a torque wrench (Tightening torque = **300 Nm**).

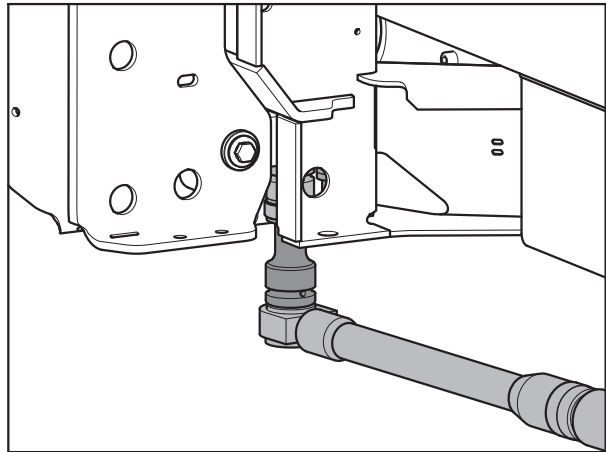

**Figure 10.5:** Fastening the weigh cells (on the left side of the direction of travel)

2. Tighten the screw connection [1] with a torque wrench (Tightening torque = **65 Nm**).

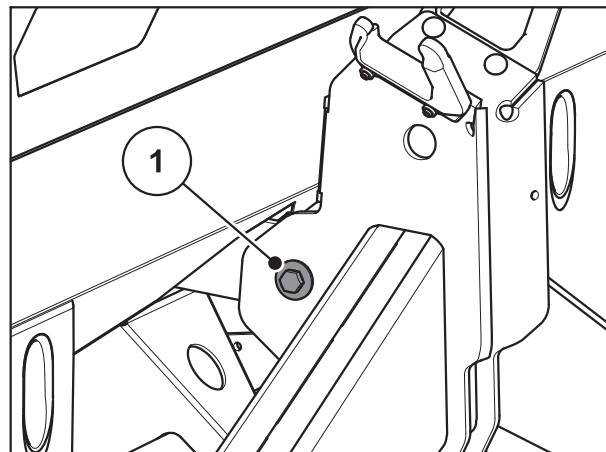

**Figure 10.6:** Fastening the tie rod at the weigh frame



3. Tighten the screw connection with a torque wrench (Tightening torque = **65 Nm**).

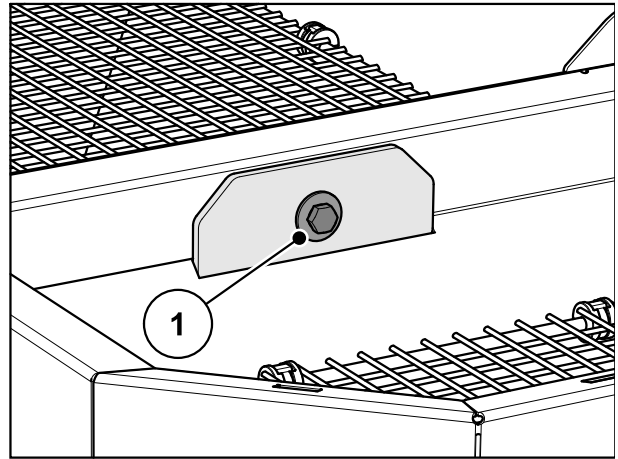

**Figure 10.7:** Fastening the tie rod at the hopper

#### **NOTICE**

After tightening the screw connections using the torque wrench, the weighing cells must be tared anew. Please follow the instructions in the chapter "Machine tare" of the operator's manual of the control unit.

10.4 Maintenance plan

Component parts	Maintenance tasks Maintenance plan	Comment
Wear parts and screw connections	Inspect regularly	<a href="#">Page 105.</a>
Plastic parts	Inspect regularly	<a href="#">Page 105.</a>
Cleaning	To be carried out after each deployment	<a href="#">Page 111</a>
Protective grid in hopper	Open the protective grid in the hopper before starting any maintenance work	<a href="#">Page 109</a>
Agitator	Check for wear	<a href="#">Page 113</a>
Removing and mounting spreading discs	<ul style="list-style-type: none"> <li>● Check for wear</li> <li>● Check tightness of cap nut (38 Nm)</li> </ul>	<a href="#">Page 78</a>
Spreading vane replacement	Check for wear	<a href="#">Page 115</a>
Spreading disc hub	Check position	<a href="#">Page 112</a>
Metering slide adjustment	Adjustment	<a href="#">Page 117</a>
Drop point setting	Adjustment	<a href="#">Page 121</a>
Transmission oil	Quantity and types; Change oil	<a href="#">Page 127</a>
Lubrication plan		<a href="#">Page 130</a>

## 10.5 Opening the protective grid in the hopper

### ▲ WARNING



#### Risk of injury due to moving parts in the hopper

There are moving parts in the hopper.

There is a risk of injury to hands and feet during commissioning and operation of the machine.

- ▶ It is important that the protective grid is installed and locked before commissioning and operating the machine.
- ▶ The protective grid may **only** be opened for maintenance purposes or in the event of a fault.

The protective grids in the hopper lock automatically by means of a protective grid lock.

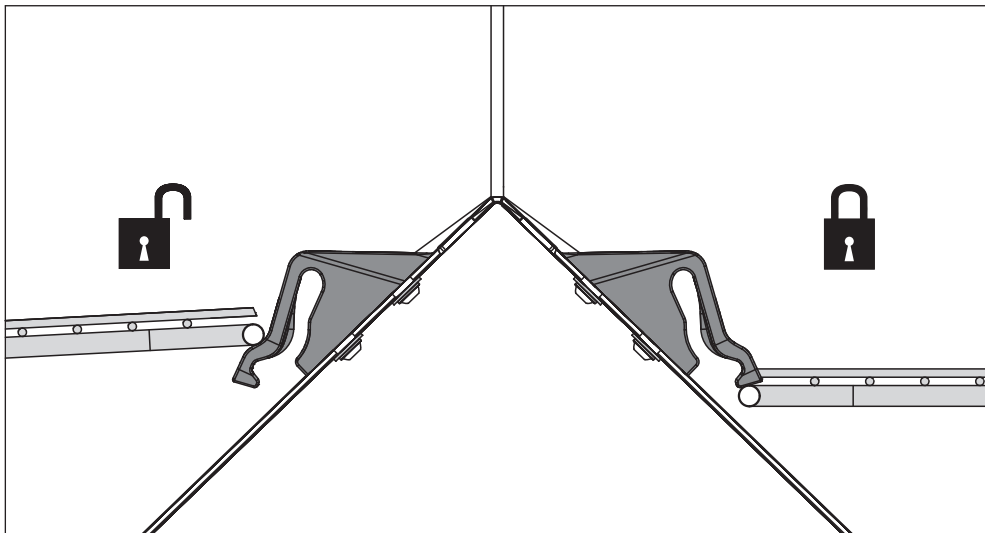
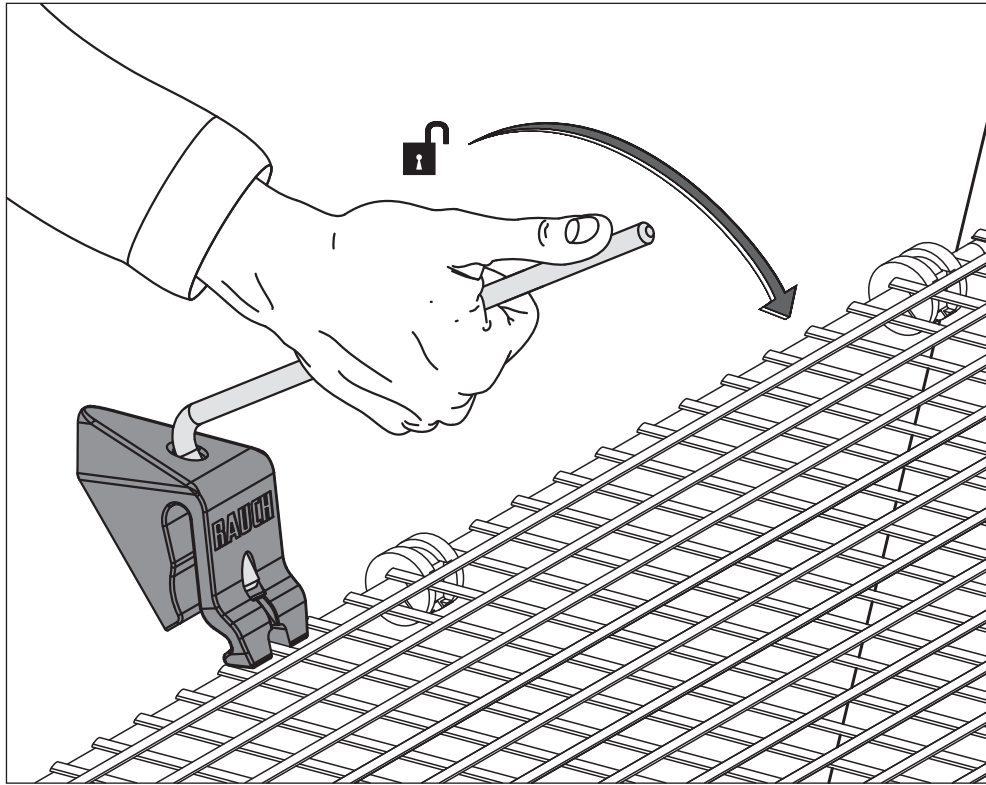

**Figure 10.8:** Protective grid lock open/closed

In order to avoid an inadvertent opening of the protective grid, the protective grid lock can only be released by using a tool (e.g. by means of the adjustment lever).

**Before opening the protective grid:**

- Disengage the PTO shaft.
- Lower the machine.
- Turn the tractor motor off. Remove the ignition key.



**Figure 10.9:** Open the protective grid lock

- Execute a regular function check of the protective grid lock. See figure below.
- Immediately replace defective protective grid locks.
- If required, correct the setting by moving the protective grid lock [1] up/down (see figure below).

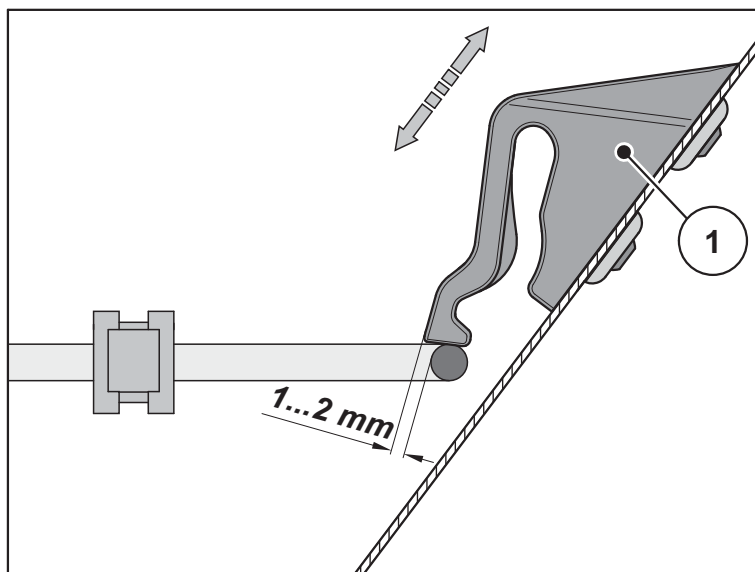

**Figure 10.10:** Test dimension for functional check of the protective grid lock

## 10.6 Cleaning

We recommend cleaning the machine immediately after every use with a gentle water jet in order to maintain its value.

To facilitate cleaning, fold up the protective grids in the hopper (see chapter [10.5: Opening the protective grid in the hopper, page 109](#)).

The following instructions must be observed for cleaning:

- Clean the outlets and the area of the slide guide from below only.
- Only clean oiled machines at washing points fitted with an oil separator.
- When cleaning with high-pressure water, never aim the jet directly at warning signs, electrical equipment, hydraulic components, and sliding bearings.

After cleaning, we recommend treating the **dry** machine, **especially the coated spreader vanes and stainless steel parts**, with an environmentally friendly anti-corrosion agent.

A suitable polishing kit can be ordered from authorised dealers for use in treating rust spots.

### 10.6.1 Disassemble the dirt deflector

- Use the adjustment lever on the machine. See [Figure 8.2, Page 86](#).

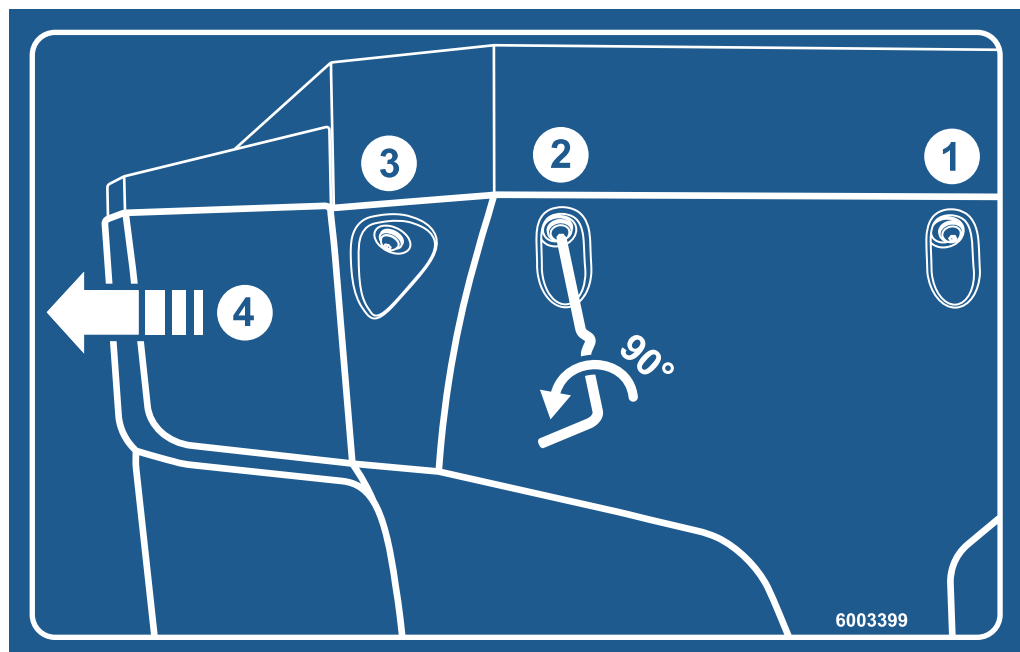

**Figure 10.11:** Dirt deflector instruction sticker

1. Open the 3 quick release closures on the left- and the right-hand dirt deflector
2. Move the dirt deflector to the outside.
3. Put the dirt deflector down and store it in a safe place.

### 10.6.2 Dismounting the dirt deflector

1. Move the dirt deflector laterally to the inside until it latches in the bracket.
2. Screw the 3 quick release closures on the left- and the right-hand dirt deflector together with the adjustment lever of the machine.
3. Put the adjustment lever back into the specified bracket.

### 10.7 Checking the position of the spreading disc hub

The spreading disc hub must be centred exactly under the agitator.

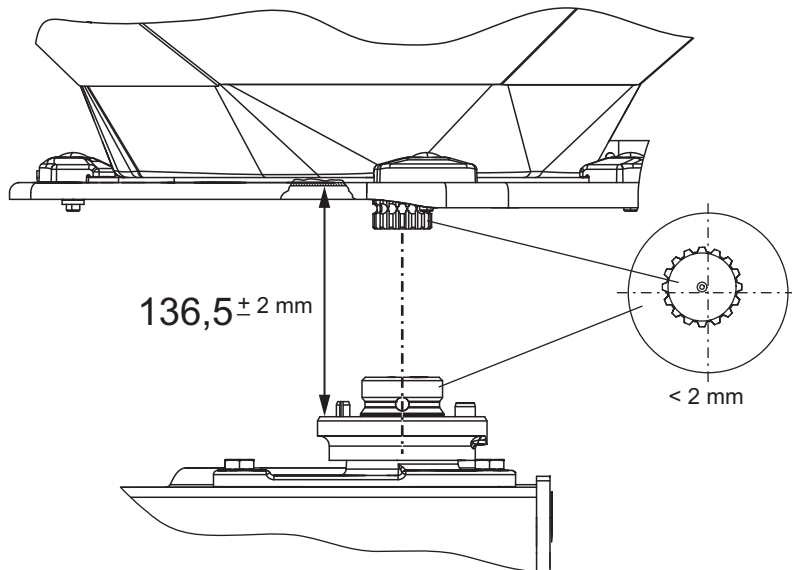

**Figure 10.12:** Checking the position of the spreading disc hub

#### Requirements:

- The spreading discs are removed (see “Dismounting spreading discs” subsection).

#### Testing the centring:

1. Use suitable equipment to check that the spreading disc hub and agitator are centred (e.g. straight edge ruler, protractor)
  - ▷ The axes of the spreading disc hub and of the agitator must be aligned. They may deviate from each other by a maximum of **2 mm**.

If this tolerance is exceeded, please contact your dealer or authorised specialist workshop.

#### Checking the distance:

2. Measure the gap between the upper edge of the spreading disc hub and the lower edge of the agitator.
  - ▷ The distance must amount to **136.5 mm** (admissible tolerance  $\pm 2 \text{ mm}$ ).

If this tolerance is exceeded, please contact your dealer or authorised specialist workshop.

## 10.8 Checking the agitator drive

### NOTICE

There is a **left-** and a **right-hand** agitator. Both agitators rotate in the same direction as the spreading discs.

The agitator must operate at a constant RPM in order to ensure an even flow of the fertiliser.

- Agitator RPM: **15 - 20** rpm.

In order to attain the correct agitator speed of **15-20** rpm, the agitator requires the resistance of the spreading material inside it. This is the reason why it is entirely possible that even with a fully functional agitator, the correct RPM cannot be attained or that the hopper seasaws, when the hopper is empty.

If the RPM **with full hopper** are outside of this range, the agitator needs to be checked for wear and tear.

### Checking the functions of the agitator

#### Requirements

- The tractor is parked.
- The ignition key has been removed.
- The machine is parked on the ground.

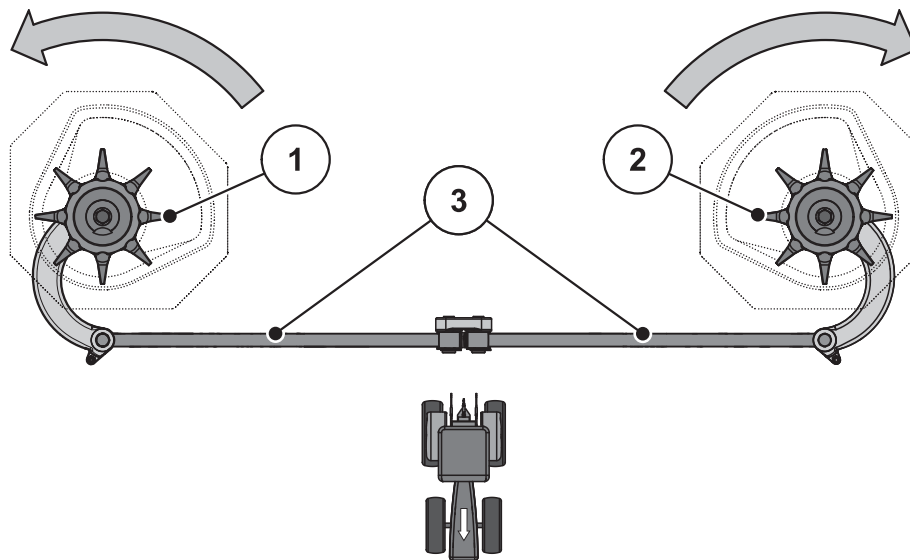

**Figure 10.13:** Checking the agitator drive

- [1] Right side agitator head (in direction of travel)  
 [2] Left side agitator head (in direction of travel)  
 [3] Connecting rods  
 Arrows: Rotational direction of spreading discs

1. Check the connecting rods.
    - Connecting rods may not show any cracks or other signs of damage.
    - Check pivoting bearing for wear and tear.
    - Check safety element functions at all joints.
  2. Manually turn the agitator head **into the rotational direction of the spreading disc**. See [Figure 10.13](#).
    - The agitator head must be able to turn.
    - ▷ If the head does not turn, replace the agitator head.
  3. Turn the agitator head manually or with the help of an oil filter belt forcefully **against the rotational direction of the spreading disc**. See [Figure 10.13](#).
    - The agitator head should not turn.
    - ▷ If the head can be turned, replace the agitator head.
- ▷ **If the checkup does not identify a cause, please contact your authorised specialist workshop for further inspections.**

**Checking the agitator head for wear and tear:**

- Check the fingers of the agitator head for wear.
  - ▷ The length of the fingers must not be less than the **wear range (Z)**.
  - ▷ The fingers must not be bent.

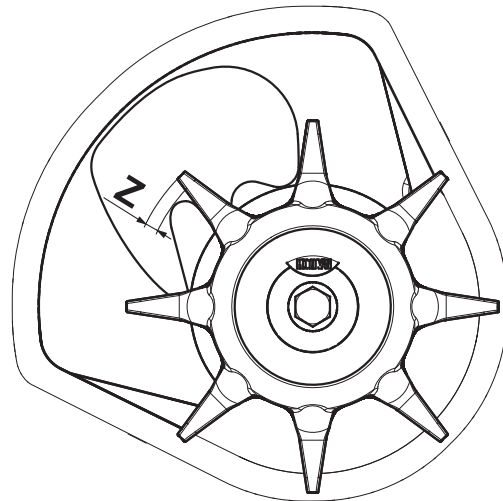

**Figure 10.14:** Agitator head wearing zone



## 10.9 Spreader vane replacement

Replace worn spreader vanes.

### NOTICE

Worn spreader vanes must **only** be replaced by your dealer or your specialist workshop.

#### Requirements:

- The spreading discs have been dismantled (see section “Dismounting and mounting spreading discs”).

#### Determination of spreader vane type:

### ⚠ CAUTION



#### Conformity of the spreader vane types

The type and size of the spreader vanes are adapted to the spreading disc. Incorrect spreader vanes can cause damage to the machine and the environment.

- ▶ ONLY use spreader vanes which are approved for the relevant disc.
- ▶ Compare the labelling on the spreader vane. The model and size of the new and old spreader vane must be identical.

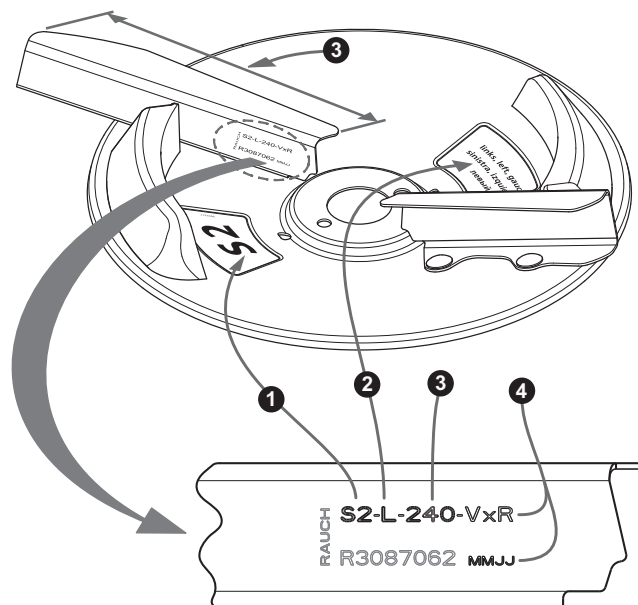

**Figure 10.15:** Spreading disc label

- [1] Spreading disc type
- [2] Spreader side
- [3] Length of the spreader vane
- [4] Coating

Replacement of spreader vanes:

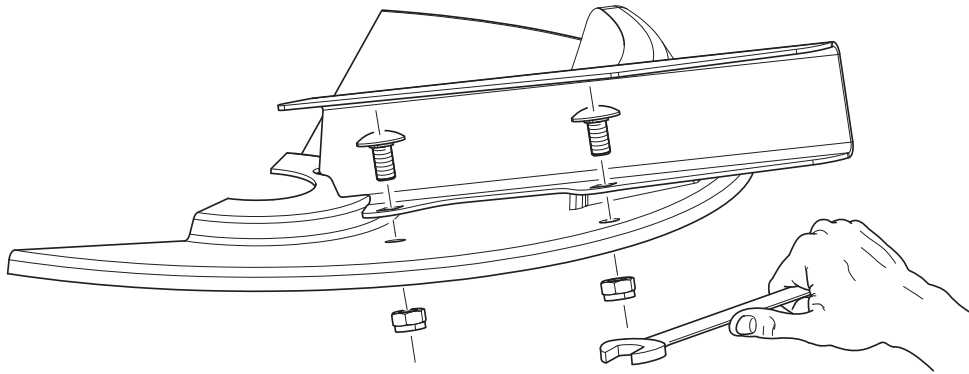

Figure 10.16: Loosen the screws on the spreader vane

1. Loosen the self-locking nuts at the spreader vane and take them off the spreader vane.
2. Install the new spreader vane onto the spreading disc. Make sure that you have the correct spreader vane type.

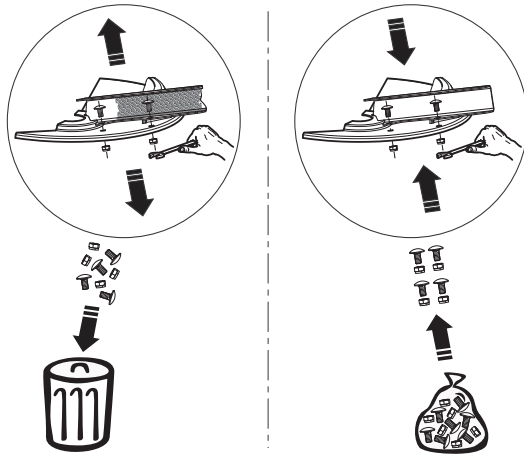

Figure 10.17: Use new self-locking nuts

3. Screw-on the spreader vane (tightening torque: **20 Nm**). For this purpose, **always use new self-locking nuts**.

## 10.10 Metering slide adjustment

Check that the metering slides open smoothly before every working season, and during the season if necessary.

### ▲ WARNING



#### Danger of crushing and shearing due to components operated by an external force

When working on power-operated components (adjusting lever, metering slides), there is a crushing and shearing risk.

Pay attention to the shear point of the metering slide opening and the metering slide during all adjustment work.

- ▶ Switch the tractor motor off.
- ▶ Remove the ignition key.
- ▶ Disconnect the power supply between the tractor and the machine.
- ▶ Never actuate the hydraulic metering slide during adjustment work.

#### Requirements:

- The mechanical system must move freely.
- The actuator/hydraulic cylinder is disengaged.

#### Check (e.g. left side of machine):



1. Insert a lower link pin with a diameter of **28 mm** centrally into the metering opening.

**Figure 10.18:** Lower link pin in metering opening

2. Push the metering slide against the pin, and lock it in this position by tightening the setscrew.
- ▷ **The stop on the lower scale plate (metering scale) is positioned at the scale value 85. If the position is not correct, readjust the scale.**

**Adjustment of AXIS-M 50.2 D:**

The metering slide is in the position of step 2 (lightly pressed against the pin).

3. Loosen the fastening screws on the scale of the lower scale plate.



**Figure 10.19:** Adjustment scale of metering slide

4. Adjust the scale in such a way that the **scale value 85** lies exactly under the pointer element. Screw the scale back on.
5. Repeat working steps for the right metering slide.

**NOTICE**

Both metering slides must open **evenly** and to the same extent. Therefore, always check both metering slides.

6. Reattach the hydraulic cylinders.

**Adjusting AXIS 50.2 W:**

The metering slide is in the position of working step 2.

7. Loosen the fixing screws of the scale arc.

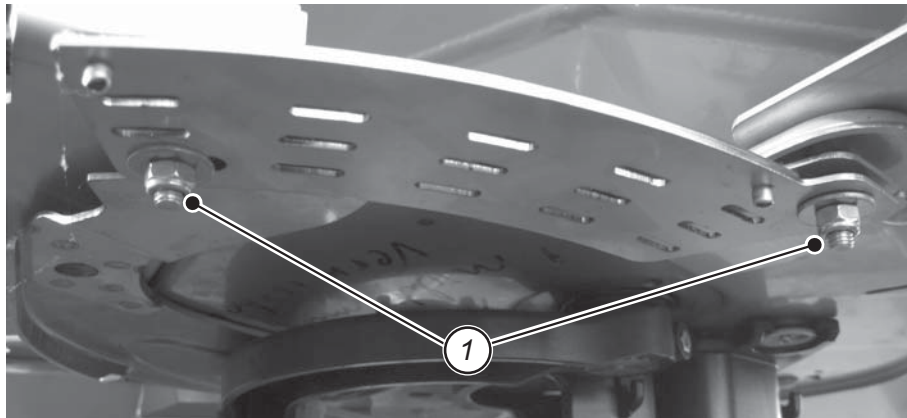

**Figure 10.20:** Scale fixing screws

8. Adjust the scale in such a way that the **scale value 85** lies exactly under the pointer element. Screw the scale back on.

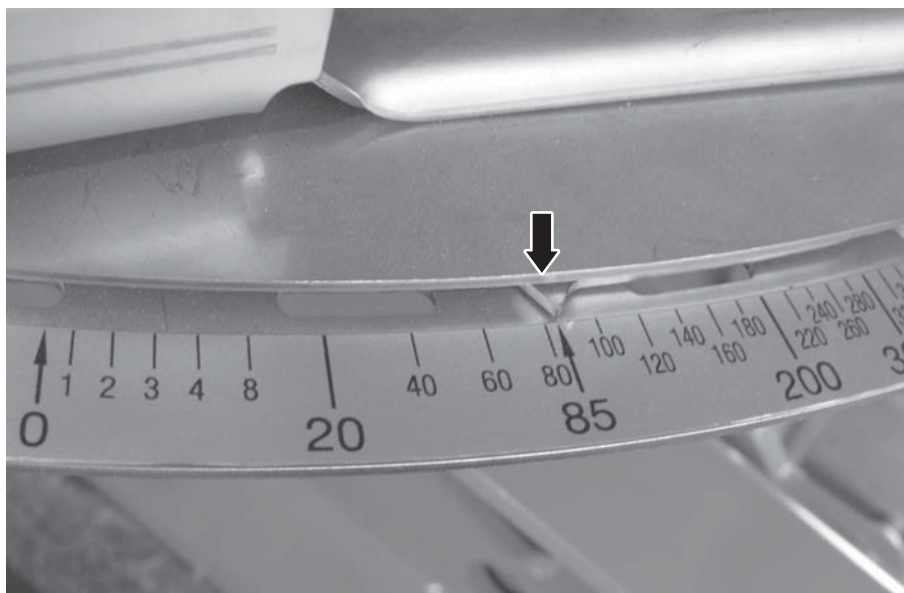

**Figure 10.21:** Metering slide pointer on position 85

9. Repeat working steps 1 - 4 for the right metering slide.
10. Reconnect the actuator to the metering slide.

### NOTICE

Both metering slides must open **evenly** and to the same extent. Therefore, always check both metering slides.

After scale correction with electronic slide actuators, a correction of the slide testing points in the operating unit is necessary.

Please observe the operator's manual for the control unit.

**Adjustment of AXIS 50.2 EMC (+ W):**

1. Insert the adjustment lever into the guide [2] under the scale plate.
2. Slowly adjust the metering slide with the adjustment lever until it lightly pressed against the pin.
3. Loosen the fixing screws [1] of the scale plate.

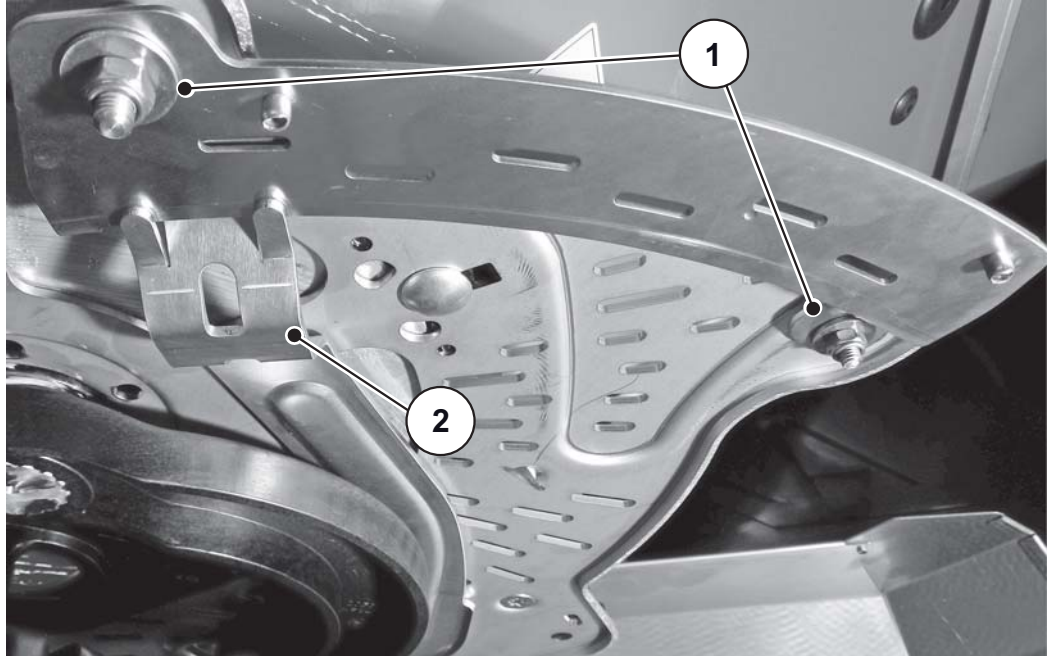

**Figure 10.22:** Fixing screws of the scale plate

4. Adjust the scale in such a way that the **scale value 85** lies exactly under the pointer element. Screw the scale back on.

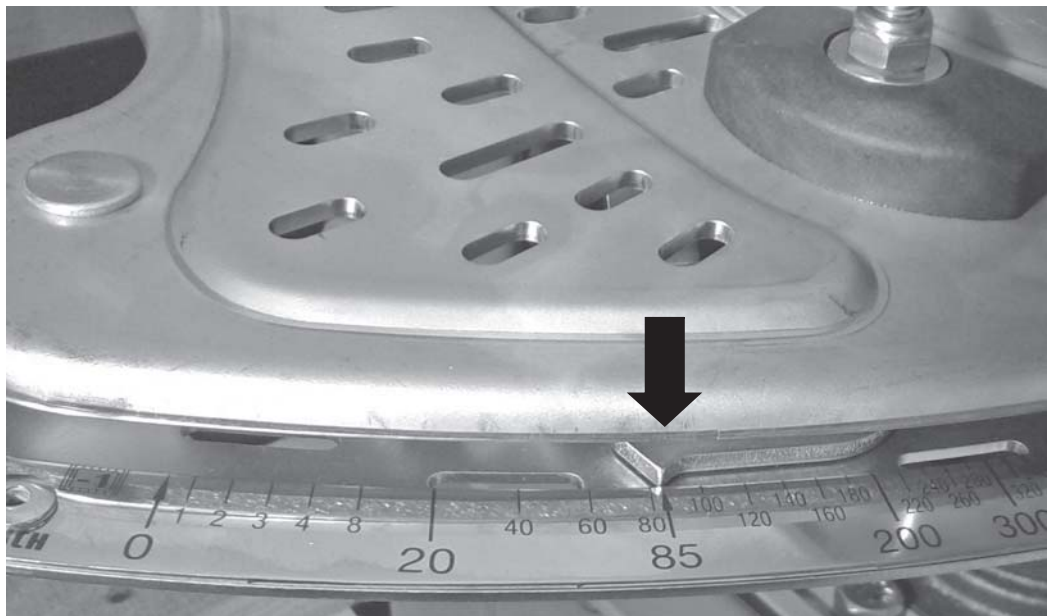

**Figure 10.23:** Metering slide pointer on position 85

5. Repeat working steps for the right metering slide.

**NOTICE**

Both metering slides must open **evenly** and to the same extent. Therefore, always check both metering slides.

After scale correction with electronic slide actuators, a correction of the slide testing points in the operating unit is necessary.

Please observe the operator's manual for the control unit.

### 10.11 Checking the drop point

By altering the drop point, the working width can be accurately set and adjustments to different fertiliser types can be made.

Check the setting of the drop point at the start of each working season, and during the season if necessary (if uneven spreading is noticed).

**NOTICE**

The drop point must be set to the **same** position on both sides. Therefore, always check both settings.

1. **AXIS 50.2 D:** Manually set the drop point to **position 6**.  
**AXIS 50.2 W,  
AXIS 50.2 EMC (+ W):**  
Set the drop point to **position 6** using the electronic system.
2. Switch off the electronic system.

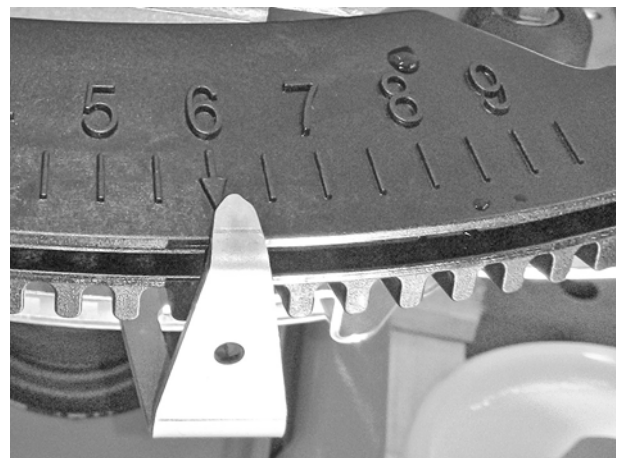

**Figure 10.24:** Setting the drop point to position 6

**⚠ WARNING**



**Danger of crushing and shearing due to components operated by an external force**

When working on power-operated components (adjusting lever, metering slides), there is a crushing and shearing risk.

Pay attention to the shear point of the metering slide opening and the metering slide during all adjustment work.

- ▶ Switch the tractor motor off.
  - ▶ Remove the ignition key.
  - ▶ Disconnect the power supply between the tractor and the machine.
  - ▶ Never actuate the hydraulic metering slide during adjustment work.
-



### 10.11.1 Checking AXIS 50.2 D:

1. Attach a suitably thin string [1] from below **at the rear** in the direction of travel (as shown) through the grooves [a] of the left and right adjustment centres and tauten it.

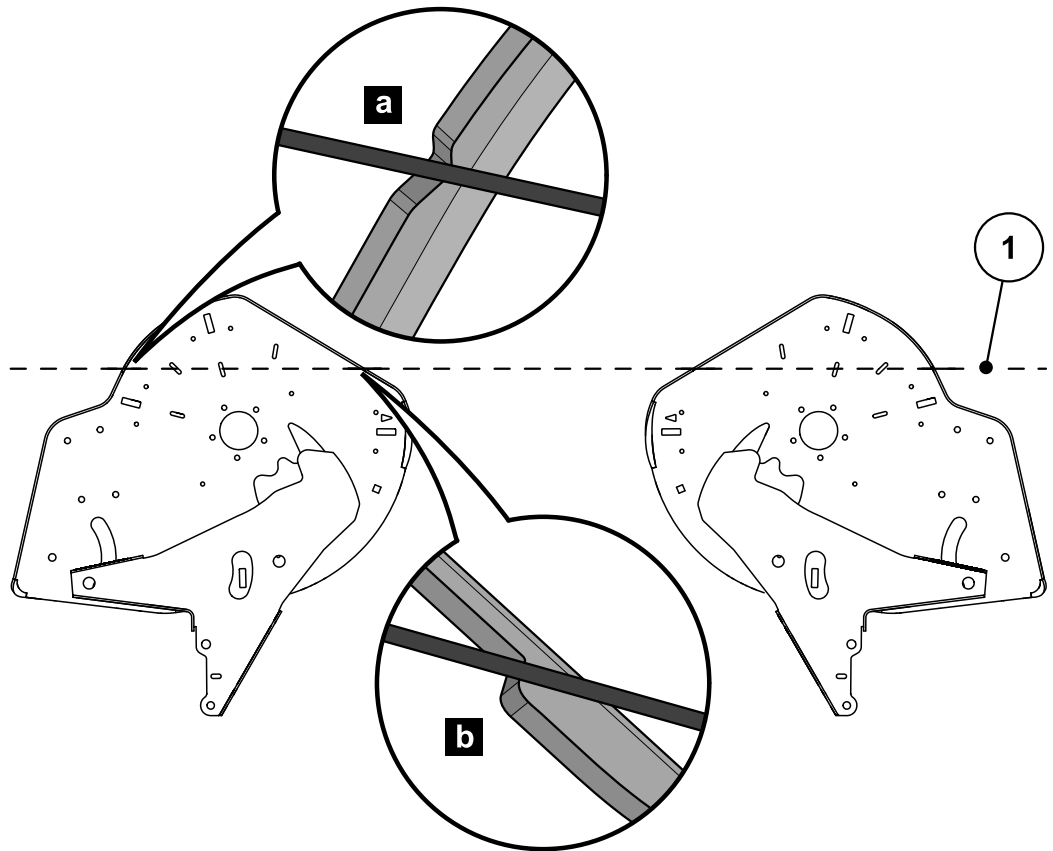

**Figure 10.25:** Checking the drop point

- The string has to run straightly through the groove [a] at the both hopper bases without any pressure and be in contact with edge [b].
- If there is no contact between the string and the edge, the drop point must be readjusted.

10.11.2 Adjusting AXIS 50.2 D:

2. Release the adjustment plate underneath the "drop point pointer" button (2 self-locking nuts).

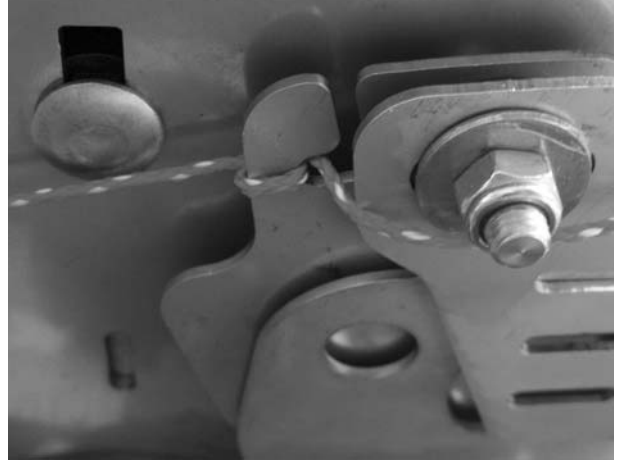

**Figure 10.26:** Loosen the drop point adjustment plate

3. Turn the adjustment centre until the marks line up with the taut string.
4. Fasten the adjustment plate.

### 10.11.3 Checking AXIS 50.2 W

1. Attach a suitably thin string **at the rear** in the direction of travel (as shown) to the lower sides of the left and right adjustment centres and tauten it.



**Figure 10.27:** Attaching the string to the adjustment centre

2. The triangular mark on the adjustment centre must coincide with the tensioned string.

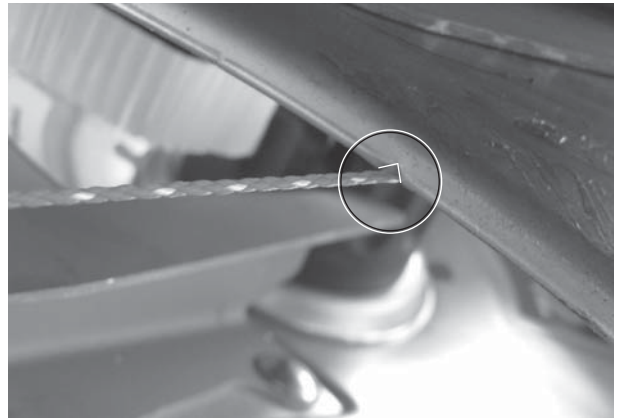

**Figure 10.28:** Markings on the adjustment centre

- If the mark is not aligned to the string, the drop point must be readjusted.

#### **NOTICE**

For adjustment of the drop point settings, please contact your dealer or an authorised specialist workshop.

10.11.4 Checking AXIS 50.2 W

1. Attach a suitably thin string [1] **at the rear** in the direction of travel (as shown) to the lower sides of the left and right adjustment centres and tauten it.  
For example, attach the string [2] at the adjustment centre of the drop point.

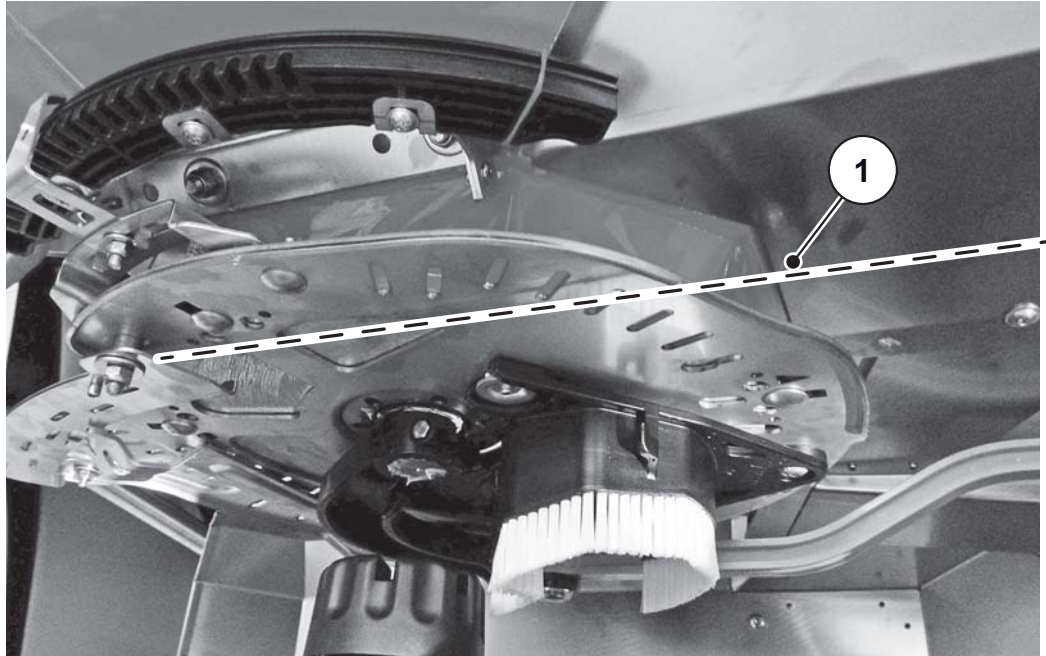

Figure 10.29: Attaching the string to the adjustment centre

2. Guide the string under the triangular markings and tighten it on the other side.

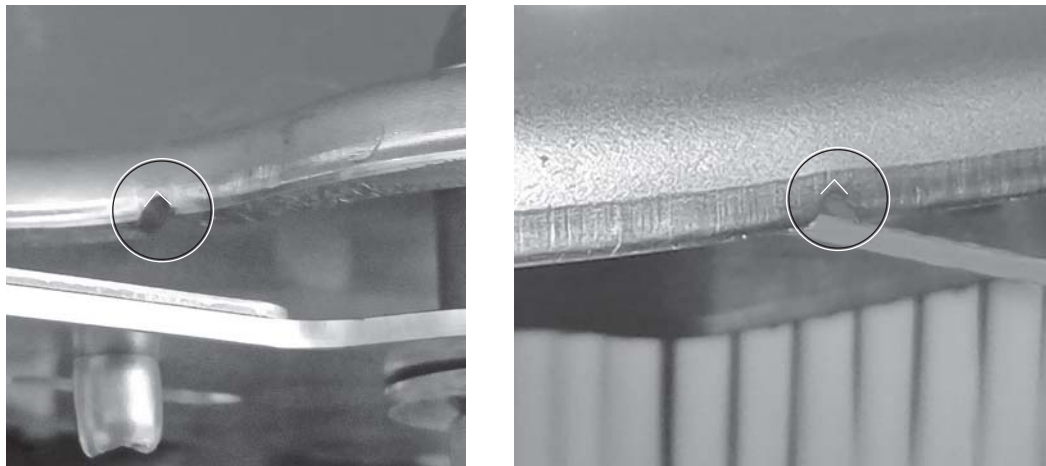

Figure 10.30: Marks at the adjustment centre

- If the mark is not aligned to the string, the drop point must be readjusted.

**NOTICE**

For adjustment of the drop point settings, please contact your dealer or an authorised specialist workshop.

## 10.12 Transmission oil (not for EMC machines)

### NOTICE

**The transmission of the machines with the M EMC function is maintenance free.**

The present chapter is not relevant for these machine variants.

### 10.12.1 Quantity and types

The transmission of the machine is filled with approx. **10.5 l** (AXIS 50.2) transmission oil.

All oils that meet the requirements of CLP 460 DIN 51517 (SAE 140 GL-4) are suitable for filling the transmission. Some of these oils are listed in the following table:

Manufacturer	Type of oil
Aral	Degol BG 460
BP	Energol GR-XP 460
Castrol	Alpha SP 460
DEA	Falcon CLP 460
Esso	Spartan EP 460
Fina	Giran 460
Mobil	Mobilgear 634
Shell	Omala Oil 460
Total	Carter EP 460
Texaco	Meropa 460

### NOTICE

Only use one type of oil.

- **Never** mix different oil types.

### 10.12.2 Checking the oil level, changing the oil

The transmission does not need to be lubricated under normal operating conditions. However, we recommend changing the oil after 10 years.

A shorter oil change interval is recommended if fertilisers with a high dust content are used and the spreader is frequently cleaned.

**Requirements:**

- The machine must be in a horizontal position to check the oil and to fill the oil. To drain the oil, the machine must be in slightly tilted position (approx. 200mm).
- PTO drive and tractor engine are stopped, the ignition key of the tractor is removed.
- When draining the oil, have a sufficiently large collecting vessel (approx. 11l) ready.

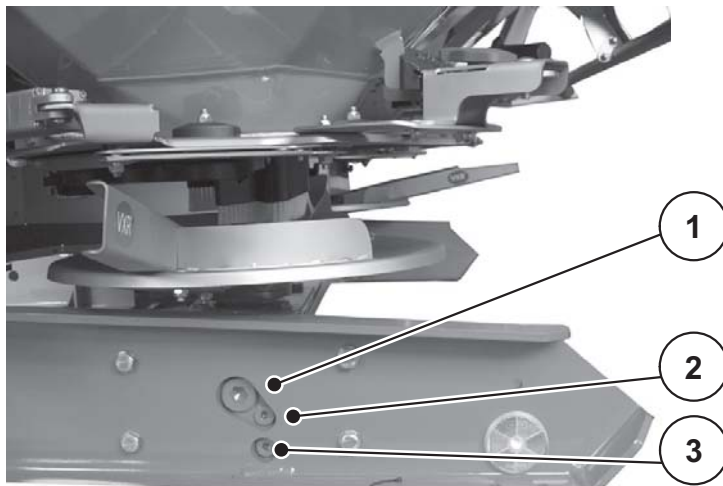

**Figure 10.31:** Transmission oil filling and draining points

- [1] Filling screw
- [2] Oil level checking screw
- [3] Drain screw

### Checking the oil level

- Open the oil level checking screw.
  - ▷ The oil level is satisfactory when the oil reaches the lower edge of the hole.

### Draining oil:

- Tilt the machine sideways (tilt approx. 200 mm).
- Position the collection vessel under the oil drain plug.
- Open the oil drain plug and let the oil drain out completely.
- Close the oil drain plug.

**▲ WARNING****Environmental pollution due to unsuitable disposal of hydraulic and gear oil**

The hydraulic and gearbox oils are not entirely biodegradable. Therefore, oil must be prevented from entering the environment in an uncontrolled manner.

- ▶ Collect/dam escaped oil with sand, earth or other absorptive material.
- ▶ Collect hydraulic and gear oil in a suitable container provided for the purpose, and dispose of it in accordance with the local statutory requirements.
- ▶ Oil must be prevented from spilling and draining into the sewers.
- ▶ The ingress of oil into the sewage system must be prevented by building dams made of sand and/or earth or by other suitable damming means.

**Filling in oil:**

- Only use SAE 140 GL-4 transmission oil.
- Open the filler hole and the check plug.
- Fill transmission oil into the filling opening until the oil level at the check plug reaches the lower edge of the hole.
- Close the filler hole and the check plug again.

10.13 Lubrication plan

Lubrication points	Lubricant	Comment
Drive shaft	Grease	See operator's manual of the manufacturer.
Metering slide, stop lever	Grease, oil	Ensure smooth movement, and grease regularly.
Spreading disc hub	Graphite grease	Ensure smooth movement of pivot and sliding surfaces and grease regularly.
Upper and lower hitch balls	Grease	Grease regularly.
Joints, bushes (agita-tor drive)	Grease, oil	They are designed for dryness but can be slightly lu-bricated.
Drop point adjustment, adjustable floor	Oil	Ensure smooth movement and oil regularly from the outer edge inward and from the base outward.

Lubrication of weighing spreader

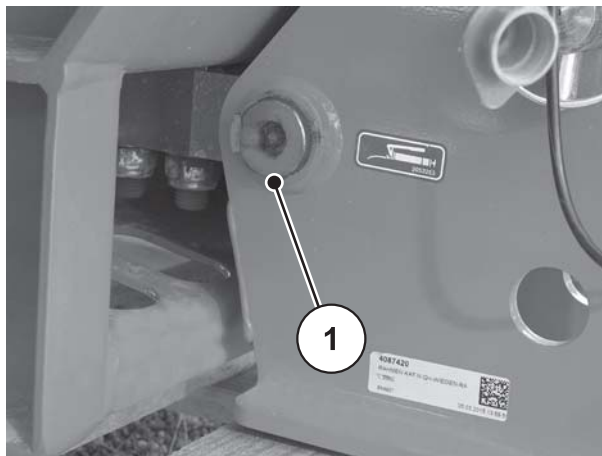

Figure 10.32: Lubrication point of weighing spreader



## 11 Disposal

### 11.1 Safety

#### ▲ WARNING



#### **Environmental pollution due to unsuitable disposal of hydraulic and gear oil**

The hydraulic and gearbox oils are not entirely biodegradable. Therefore, oil must be prevented from entering the environment in an uncontrolled manner.

- ▶ Collect/dam escaped oil with sand, earth or other absorptive material.
- ▶ Collect hydraulic and gear oil in a suitable container provided for the purpose, and dispose of it in accordance with the local statutory requirements.
- ▶ Oil must be prevented from spilling and draining into the sewers.
- ▶ The ingress of oil into the sewage system must be prevented by building dams made of sand and/or earth or by other suitable damming means.

#### ▲ WARNING



#### **Environmental pollution caused by inappropriate disposal of packaging materials**

Packaging material contains chemical compounds, which must be dealt with appropriately.

- ▶ Packaging material is to be disposed of at an authorized waste management company.
- ▶ Observe the national regulations.
- ▶ Packaging material may **not** be burned nor disposed of with the domestic waste processing.

#### ▲ WARNING



#### **Environmental pollution caused by inappropriate disposal of components**

The incorrect disposal of ingredients and materials is a threat to the environment.

- ▶ Only authorised companies may be commissioned with the disposal.

### 11.2 Disposal

The following points are applicable without any restriction. Stipulate suitable precautionary measures based on the national legislation and implement them.

1. All components, auxiliary and operating materials from the machine must be removed by specialist staff.

Hereby, these components and substances must be cleanly separated into categories.

2. All waste products are then to be disposed of in accordance with local regulations and directives for recycling or special refuse categories by authorised companies.

## Index

### A

- Attachment
  - Height 47
  - Position 43
- Axle load calculation 31

### C

- Calibration test 87–94
- Commissioning 37
  - Accepting the machine 37
  - Checks before ~ 9

### D

- Dimensions 26
- Dirt deflector
  - disassembly 111
  - Mounting 112
- Discharging residual material 95
- Disposal 131
- Distance washers 42
- Drive shaft
  - Dismounting 41
  - Mounting 38
  - Ratchet clutch 38
  - Safety equipment 16
  - Tele-Space 38
- Drop point 80
  - Adjustment 121

### E

- Electronic metering slide actuator 46
- EMC 25
- Extension combination 27

### F

- Faults 97
- Fertiliser 10
- Fertiliser chart 54, 75
- Fertiliser identification system DIS
  - See fertiliser identification system
- Fertilizer identification system 30
- Filling level scale 53
- Full border spreading 57, 60

### G

- GSE, see limited border spreading

### H

- Headlands 83
- Homologation sign 20
- Hydraulic slide actuator 46
- Hydraulic system 10

### I

- Instructions
  - Instruction stickers 19
  - User instructions 3
  - Warning stickers 18
- ISOBUS 37

### L

- Late fertilising 51, 58
- Lighting
  - Reflector 20
  - Special equipment 29
- Limited border spreading 56, 59
  - Boundary spreading unit 61–62
  - Special equipment 29
  - TELIMAT 63–66
- Lubrication
  - Version W 130

### M

- Machine
  - Acceptance 37
  - Attachment to the tractor 42
  - Description 21
  - Disposal 131
  - Filling 8, 53
  - Filling level scale 53
    - intended use 1
  - Misuse 1
  - parking 8, 96
  - Transportation 13
  - Unhitch 96
- Machine control unit
  - ISOBUS 37
- Maintenance
  - Drop point 121
  - Metering slide 117–118
  - Safety 12
  - Weigh cells 106
- Maintenance staff
  - Qualification 11

## Index

---

Manufacturer 21

Metering slide

Adjustment 117

Scale 118

Metering slide actuator

electronic ~ 46

Misuse 1

Mounting

Height 82

## N

Nameplate 20

Normal fertilisation 50, 55

## O

Operating unit

QUANTRON-A 37

Operational safety 8

Operator's manual

Layout 3

Operator's manual 3, 37

Instructions 4

## P

Protective grid 16

Lock 16, 109–110

opening 109

## Q

QUANTRON-A 37

## R

Reflector 20

## S

Safety 5–20

10

Accident prevention 8

Fertiliser 10

Maintenance 12

Operation 8

Reflector 20

Safety equipment 14

Spreading operation 73

Sticker 17

Traffic 13

Transportation 13

Warning notes 5

Wear parts 11

Safety equipment 16

Drive shaft 16

Position 14

Protective grid 16

Spreading disc cover 16

Section control 85

Service 12

Slide actuator

hydraulic ~ 46

Version D 46

Version W 46

Special equipment 28–30

Boundary spreading unit 29

Extension 27–28

Fertiliser identification system DiS 30

Hopper cover 28

Lighting 29

Practice test kit 30

Spreader vane set 30

Stabilising rollers 29

Spreading disc 77

Dismounting 78

Mounting 79

Safety equipment 16

Spreading operation 73–95

Drop point 80

Faults 97

Headlands 83

Introduction 74

Late fertilising 58

Normal fertilisation 55

Spreading quantity 75

Working width 77

Spreading quantity 75

Version EMC 75

Steps 102

Sticker 17

Homologation sign 20

Instructions 19

Nameplate 20

Warning notes 18

## T

Technical data 21–30

Dimensions 26

Extensions 27

Weights and loads 27

## B

TELIMAT 56–57, 59–60, 63–66

Terminal

    ISOBUS 37

Three-point linkage

    Category II 38

Tractor

    Requirement 38

Transportation 35

## **U**

Urea 54

Use

    intended ~ 1

User instructions 3

## **V**

VariSpread 85

Version D 25, 46, 76

Version EMC 25, 75

Version W 25, 75, 130

## **W**

Warning notes

    Meaning 5

    Sticker 18

Weigh cells 106

Weights and loads 27

Working width 77



## Terms/conditions of warranty

RAUCH units are manufactured with modern production methods and with the greatest care and are subject to numerous inspections.

Therefore RAUCH offers a 12-month warranty subject to the following conditions:

- The warranty begins on the date of purchase.
- The warranty covers material and manufacturing faults. Our liability for third-party products (hydraulic system, electronics) is limited to the warranty of the manufacturer of the equipment. During the warranty period, manufacturing and material faults are corrected free of charge by replacement or repair of the affected parts. Other rights extending beyond the above, such as claims for conversion, reduction or replacement for damages that did not occur in the object of supply are explicitly excluded. Warranty services are provided by authorised workshops, by RAUCH factory representatives or the factory.
- The following are excluded from coverage by the warranty: natural wear, dirt, corrosion and all faults caused by improper handling and external causes. The warranty is rendered void if the owner carries out repairs or modifications to the original state of the supplied product. Warranty claims are rendered void if RAUCH original spare parts were not used. Therefore, the directions in the operating manual must be observed. In all cases of doubt contact our sales representatives or the factory directly. Warranty claims must be submitted to the factory by 30 days at the latest after occurrence of the problem. The date of purchase and the serial number must be indicated. If repairs under the warranty are required, they must be carried out by the authorised workshop only after consultation with RAUCH or the company's appointed representatives. The warranty period is not extended by work carried out under warranty. Shipping faults are not factory faults and therefore are not part of the warranty obligation of the manufacturer.
- No claims for compensation for damages that are not part of RAUCH machines themselves will be accepted. This also means that no liability will be accepted for damage resulting from spreading errors. Unauthorised modifications of RAUCH machines may result in consequential damage, for which the manufacturer will not accept any liability. The manufacturer's liability exclusion will not apply in case of wilful intent or gross negligence by the owner or a senior employee, and in cases where – according to the product liability law – there is liability for personal injury or material damage to privately used objects in the event of defects in the supplied product. It will also not apply in the event that assured properties are absent, if the purpose of the assured properties was to protect the purchaser against damage that does not involve the supplied product itself.

**RAUCH Streutabellen**  
**RAUCH Fertilizer Chart**  
**Tableaux d'épandage RAUCH**  
**Tabele wysiewu RAUCH**  
**RAUCH Strooitabellen**  
**RAUCH Tabella di spargimento**  
**RAUCH Spredetabellen**  
**RAUCH Levitystaulukot**  
**RAUCH Spridningstabellen**  
**RAUCH Tablas de abonado**



<http://www.rauch-community.de/streutabelle/>



**RAUCH**

POWER FOR PRECISION

**RAUCH Landmaschinenfabrik GmbH**



Landstraße 14 · 76547 Sinzheim



Victoria-Boulevard E200 · 77836 Rheinmünster

Phone +49 (0) 7221/985-0 · Fax +49 (0) 7221/985-200  
info@rauch.de · www.rauch.de

